

Not legal for sale or use on any pollution controlled motor vehicle



WE ARE FUEL DELIVERY



**9x Recipient : SEMA New Product Awards**

Aeromotive Inc. is a true high performance manufacturer specializing in fuel delivery and fuel delivery components. Combining three generations of racing experience with ground-breaking innovation and aerospace manufacturing standards, Aeromotive delivers performance and quality that is second to none.

**2018 SEMA MANUFACTURER OF THE YEAR**

Aeromotive has created a line of fuel system products that have become the absolute pinnacle of performance fuel delivery.

**Committed to Engineering the Next Generation of Fuel Delivery Solutions**



- 02** New Products
- 06** Fuel Pumps
  - 07 • A750
  - 08 • Stealth 340 Series
  - 10 - Phantom Series
  - 14 - Gen II Stealth Tanks
  - 16 • A1000
  - 18 • Eliminator
  - 20 • ProSeries
  - 21 • Brushless Gear Pumps
  - 22 • Carbureted T-Style Pumps
- 24** Mechanical Pumps
  - 24 • Spur Gear
  - 26 • Gerotor
- 28** Diesel
- 30** Fuel Pressure Regulators
  - 30 • Fuel Injection
  - 34 • Carbureted
- 40** Fuel Filters
- 43** Fuel Rails
- 46** Accessories
- 54** Power Planner Diagrams

**WARNING :** This product can expose you to chemicals, including chromium, which is known to the State of California to cause cancer or birth defects or other reproductive harm.

# APEX PHANTOM

Features Jet Siphon Technology To Pick Up Fuel From The Corner Of The Tank Or Saddle Bag

## Phantom 340 Apex Kit - #18704

EFI	Naturally Aspirated	Forced Induction
GAS	725hp	595hp
E85	505hp	415hp

## Phantom 450 Apex Kit - #18705

EFI	Naturally Aspirated	Forced Induction
GAS	975hp	700hp
E85	660hp	485hp

## Jet Siphon Only Kit - #18706

See more information on page 12



## BLADDER BAFFLES

Optional Valves Eliminate Fuel Starvation in Extreme Applications.

- Phantom 200 & 340 includes 4 valves
- Phantom 450 & Dual includes 5 valves
- Trifekta Phantom includes 10 valves

Valves, Gasket & Bladder	Valves & Gasket
#18040	#18020
#18041	#18021
#18042	#18022



US Phantom Patent Nos.  
8,783,287  
9,567,954



# TRIFEKTA™ PHANTOM SERIES

## Part Number #18311

- Triple 450lph Fuel Pumps
- Larger 6" Billet Cap : Drill 4.5" hole
- ORB-08 Outlet, Vent & Return Ports
- Three Sets of Electrical Terminals  
Main Pump : Auxiliary Pumps : Fuel Level Sending Unit

		Naturally Aspirated	Forced Induction
GAS	EFI	3,300hp	2,400hp
	Carb	3,900hp	2,850hp
E85	EFI	2,250hp	1,650hp
	Carb	2,700hp	2,100hp

See more information on page 13

**WARNING:** This product can expose you to chemicals, including chromium, which is known to the State of California to cause cancer or birth defects or other reproductive harm.

# GEN III STEALTH TANKS

- Fuel Pump, baffle and fuel level sending unit preinstalled and plumbed to a billet end cap in the factory outlet location
- Aeromotive's Patented Phantom Baffle System keeps the fuel pump submerged in fuel at all times.
- Available with 200lph or 340lph Pumps
- Compatible with Carb or EFI
- Available for Popular Muscle Cars

US Phantom Patent Nos.  
8,783,287  
9,567,954

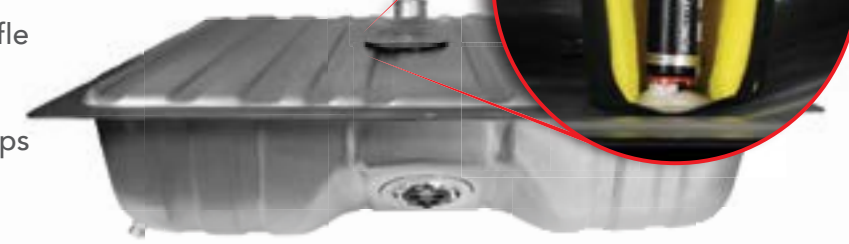

## UTILIZES OEM FUEL OUTLET LOCATION



## PATENTED & AWARD WINNING PHANTOM TECHNOLOGY



## PLUG+PLAY NO ASSEMBLY REQUIRED



For more information and a complete list of applications, see page 14

# FOX BODY STEALTH 340

Part Number #18638 | 1986 - 1997 Ford Mustang

Billet and stainless fuel pump hanger and high flow 340 Stealth pump assembly that provides a high-flow, high horsepower fuel pump installation for stock 86-97 Mustang fuel tanks, eliminating both fuel starvation and return aeration common to the factory Mustang hanger.



## BILLET FUEL CELL CAP

- 12 BOLT #18707 For Aeromotive Fuel Cells
- WELD-ON #18708 Custom Fuel Cells - 3.5" hole



## MECHANICAL FUEL PUMP BELT DRIVE BRACKET WITH DRIVE

PASSENGER SIDE  
#11708

DRIVER SIDE  
#11707

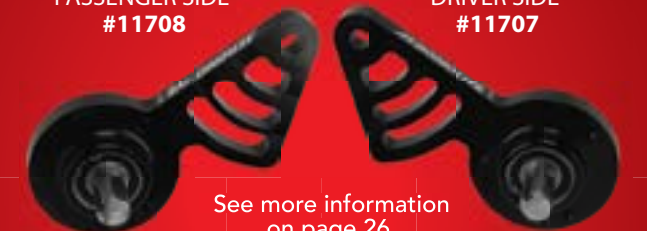

See more information on page 26

# BRUSHLESS FUEL PUMP SERIES

- HIGHER EFFICIENCY
- LOWER CURRENT DRAW
- LESS HEAT
- EXTENDED LIFE

After years of research and development, Aeromotive created four new brushless pumps – the Brushless A1000, the Brushless Eliminator, the 3.5gpm and the 5.0gpm Gear Pumps. The company's new brushless technology creates less heat, draws less power and eliminates the potential for wear – ideal for dual purpose applications requiring a continuous duty fuel pump.

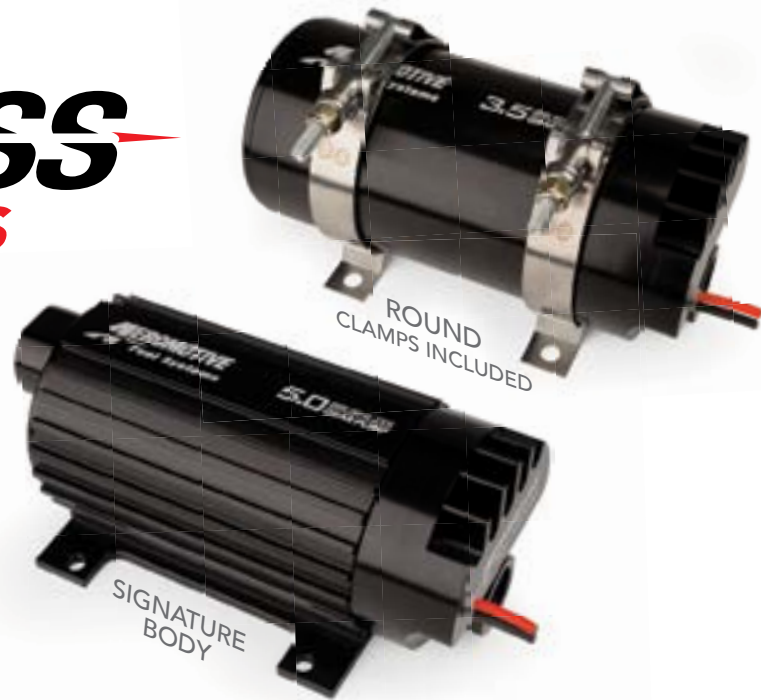

**NEW TRUE VARIABLE SPEED** - Aeromotive's line of brushless pumps are available with two different built-in controllers: The Standard Configuration of Aeromotive's Brushless Controllers, which provides continuous full-speed operation, and the New True Variable Speed Controller (TVS), which offers the advantage of pump speed control via a 0-5V analog DC input signal. The TVS controller capitalizes on our existing brushless technology by reducing fuel flow during low-demand, decreasing an already low current draw, and, therefore, minimizing the introduction of heat even further.

Upgrade your existing Brushless pump with part #18047 True Variable Speed Controller. { AVAILABLE JULY 2019 }



EXTERNAL IN-LINE ROUND or SIGNATURE



COMPLETE FUEL CELLS AVAILABLE IN 6, 15 or 20 GALLON



FUEL CELL MODULE DIRECT DROP IN or UNIVERSAL

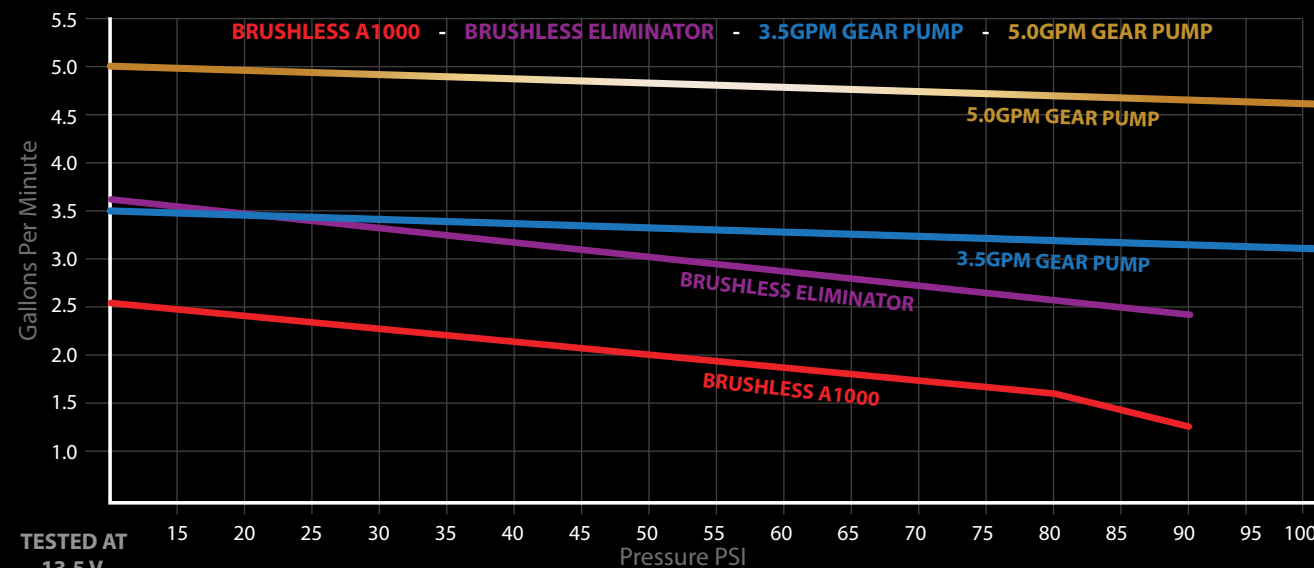

## COMPLETE FUEL CELL

The Brushless A1000 and Eliminator feature the same legendary roller vane pumping mechanisms that have been trusted for decades, now simply offered with the latest in electric motor technology.

{ TRUE VARIABLE SPEED AVAILABLE JULY 2019 }

BRUSHLESS A1000		TRUE VARIABLE SPEED
EXTERNAL ROUND	STANDARD #11124	VARIABLE #11189
SIGNATURE	#11183	#11193
IN-TANK 10" DROP-IN	STANDARD #18023	VARIABLE #18043
UNIVERSAL	#18368	#18388
FUEL CELL 6 GALLON	STANDARD #18366	VARIABLE #18386
15 GALLON	#18360	#18380
20 GALLON	#18361	#18381

GAS	NA	FI
EFI CARB	1,300hp	1,000hp
	1,500hp	1,200hp
E85	NA	FI
EFI CARB	910hp	700hp
	1,050hp	840hp

BRUSHLESS Eliminator		TRUE VARIABLE SPEED
EXTERNAL ROUND	STANDARD #11180	VARIABLE #11190
SIGNATURE	#11184	#11194
IN-TANK 10" DROP-IN	STANDARD #18024	VARIABLE #18044
UNIVERSAL	#18369	#18389
FUEL CELL 6 GALLON	STANDARD #18367	VARIABLE #18387
15 GALLON	#18362	#18382
20 GALLON	#18363	#18383

GAS	NA	FI
EFI CARB	1,900hp	1,400hp
	2,300hp	1,700hp
E85	NA	FI
EFI CARB	1,330hp	980hp
	1,610hp	1,190hp



## BRUSHLESS GEARPUMPS

The real highlight of this new series is the Brushless Gear Pumps. Aeromotive took what they learned from their mechanical spur gear pumps, and engineered it to work in a compact flow thru design. This creates a fuel pump that is able to move more fuel at pressures up to 150psi, without a significant drop in flow resulting in the highest flowing electric fuel pump in the aftermarket.

3.5GPM GEARPUMPS		TRUE VARIABLE SPEED
EXTERNAL ROUND	STANDARD #11181	VARIABLE #11191
SIGNATURE	#11185	#11195
IN-TANK 10" DROP-IN	STANDARD #18025	VARIABLE #18045
UNIVERSAL	#18374	#18394
FUEL CELL 6 GALLON	STANDARD #18376	VARIABLE #18396
15 GALLON	#18370	#18390
20 GALLON	#18371	#18391

GAS	NA	FI
EFI CARB	2,400hp	1,800hp
	2,600hp	2,000hp
E85	NA	FI
EFI CARB	1,680hp	1,260hp
	1,820hp	1,400hp

5.0GPM GEARPUMPS		TRUE VARIABLE SPEED
EXTERNAL ROUND	STANDARD #11182	VARIABLE #11192
SIGNATURE	#11186	#11196
IN-TANK 10" DROP-IN	STANDARD #18026	VARIABLE #18046
UNIVERSAL	#18375	#18395
FUEL CELL 6 GALLON	STANDARD #18377	VARIABLE #18397
15 GALLON	#18372	#18392
20 GALLON	#18373	#18393

GAS	NA	FI
EFI CARB	3,400hp	2,600hp
	3,600hp	2,700hp
E85	NA	FI
EFI CARB	2,380hp	1,820hp
	2,520hp	1,890hp

{ TRUE VARIABLE SPEED AVAILABLE JULY 2019 }



IN-TANK FUEL CELL MODULE

# FLOW CURVES

Performance, reliability, and durability are designed into every performance fuel pump that carries the AEROMOTIVE name. And, rest assured, **EVERY pump is tested for flow at a prescribed pressure, current draw, and leakage.** Once the pumps pass our test, then and only then do they get date-stamped and packaged, ready to quench the thirst of some of the hungriest beasts that roam our planet.

▲ 12 Volts ■ 13.5 Volts

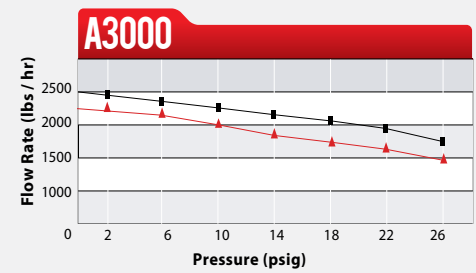
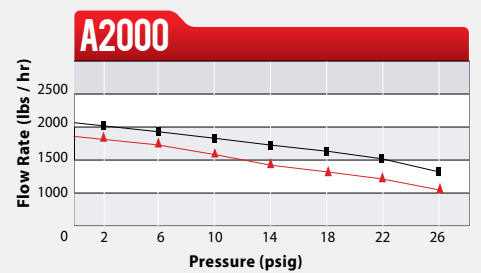
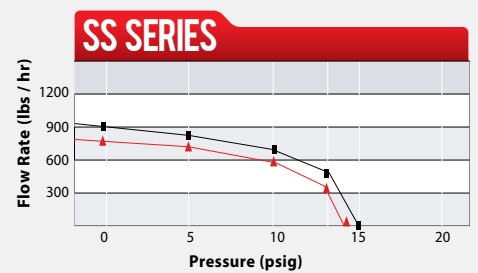
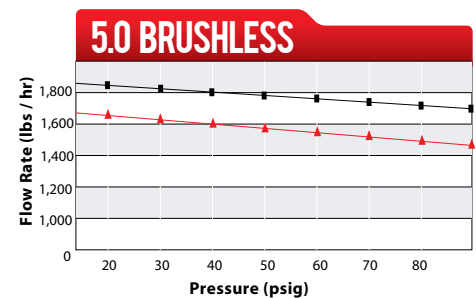
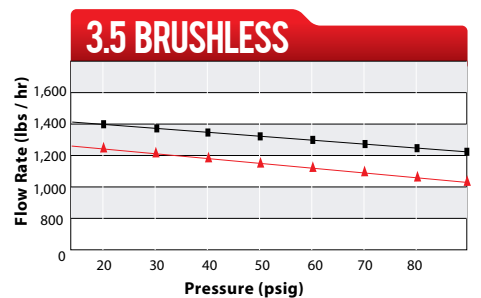
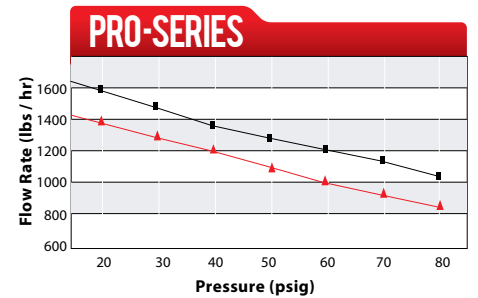
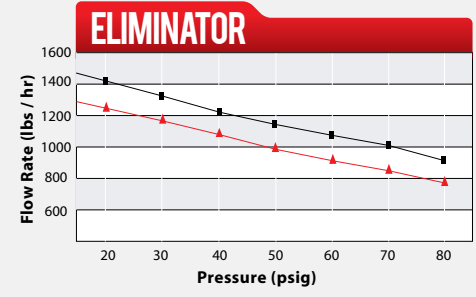
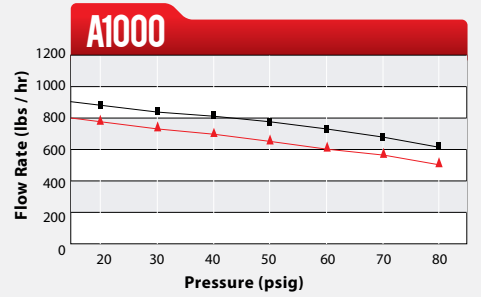
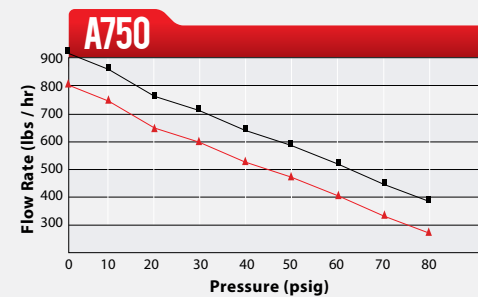
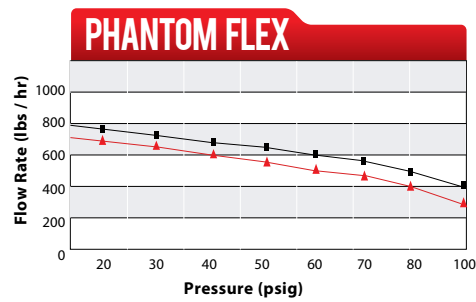
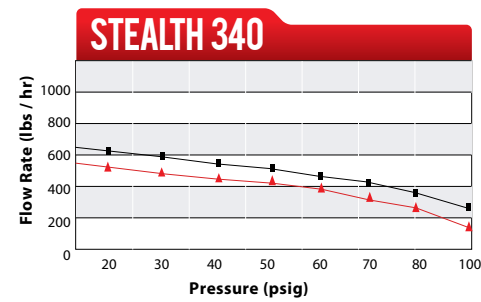
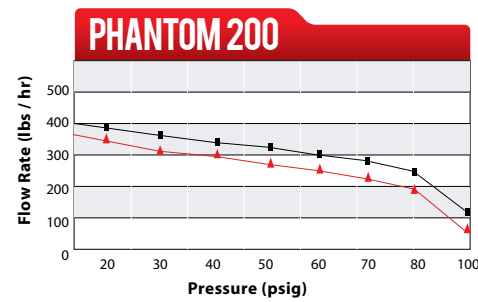
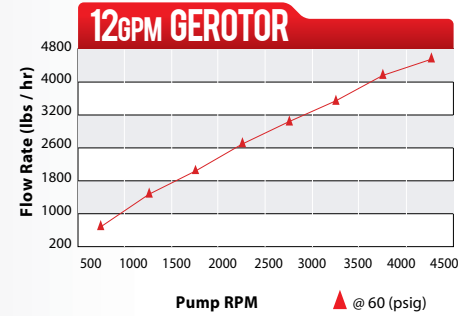
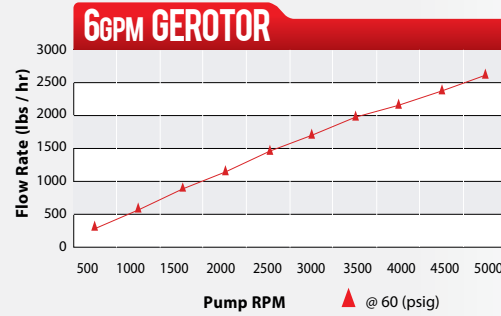

# A750

Compact, quiet and durable, these billet, in-line pumps are ideal for low to medium HP applications. Perfect for street rods and muscle cars, fuel injected or carbureted.

- ORB-08 inlet ports and ORB-06 outlet ports.
- EFI applications use regulator #13129 or #13109.
- Carb applications use regulator #13204 or #13304.
- Fully submersible for custom, in-tank placement.

**BLACK #11103**  
**RED #11106**  
**PLATINUM #11156**

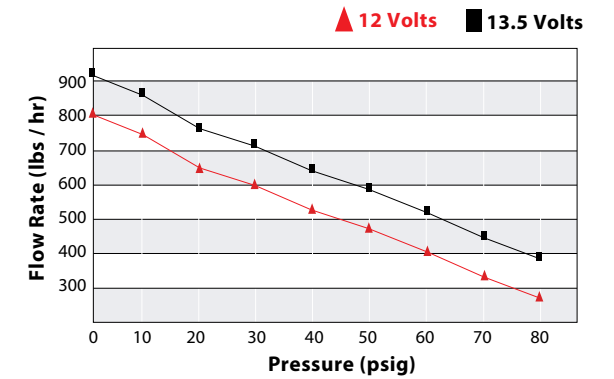

GAS	Naturally Aspirated	Forced Induction
Fuel Injected	800hp	600hp
Carbureted	1,000hp	800hp

E85	Naturally Aspirated	Forced Induction
Fuel Injected	560hp	420hp
Carbureted	700hp	560hp

EFI - 550lbs/hr 45psi 13.5v CARB - 700lbs/hr 8psi 13.5v

## A750 SYSTEMS

Include: Filters, regulator, port fittings, hose, hose-ends, wiring and installation hardware.

#17135 : EFI System with Black #11103 & #13109 Regulator  
#17136 : EFI System with Red #11106 & #13109 Regulator

# STEALTH 325 #11565



- Flows 325 lph @ 40 psi
- Internal check valve
- Quiet, durable and reliable turbine impeller
- Designed for in-tank use only
- Can be used in pulse width modulation

## Fuel Injected Engines

- up to 800hp - naturally aspirated
- up to 700hp - forced air induction

**Acura** RSX 02-06 #11565

**Ford**  
F150/F250 97-04 #11565  
F150 Harley-Davidson 02-03 #11565  
Focus RS I5 Turbo 09-10 #11565  
Mustang 99-04 #11565  
Mustang (exc. GT500) 05-10 #11565

**Holden** Commodore 07-13 #11565

**Honda** Civic 06-13 #11565  
**Honda** Civic 01-05 #11565

**Lotus** Elise 2004+ #11565  
**Lotus** Exige 2004+ #11565

**Mazda**  
MazdaSpeed3 07-12 #11565  
MazdaSpeed6 06-07 #11565  
MX5 2006-2013 #11565

**Mitsubishi** EVO X 08-14 #11565

**Nissan** R35 GTR 08-14 (x2) #11565

**Pontiac** GTO 04-06 #11565

**Scion** FR-S 2013+ #11565

**Subaru**  
Legacy GT 05-09 #11565  
WRX/STi 08-12 #11565  
BRZ 2013+ #11565

**Toyota**  
Celica 2000-05 #11565  
MR2 Spyder 2000-05 #11565  
Corolla 03-04 #11565  
Matrix 03-04 #11565

# STEALTH 340

The Aeromotive Stealth Fuel Pumps are high-output, in-tank, electric fuel pumps perfect for both fuel injected and carbureted applications. Not only do these pumps bolt into many existing hanger assemblies but they also serve as the basis for many Aeromotive Stealth products.

- Fully E85 compatible
- Multiple inlet configurations
- Includes universal filter sock & pigtail
- Designed for in-tank use only
- Can be used in Carbureted or EFI applications
- Whisper quiet operation
- Turbine pump mechanism increases durability and can be used in pulse width modulated applications

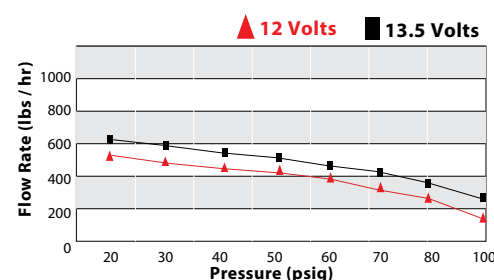

GAS	Naturally Aspirated	Forced Induction
Fuel Injected	850hp	700hp
Carbureted	1,000hp	850hp

E85	Naturally Aspirated	Forced Induction
Fuel Injected	595hp	490hp
Carbureted	700hp	595hp



#11569  
Center offset  
(GM app)

#11540  
Center Inlet



#11541  
Inlet Offset  
from Outlet



#11542  
Inlet In-Line  
from Outlet

# 340 CELLS

- Features (x1) ORB-08 outlet and (x1) AN-08 return
- Includes (x2) AN-08 vents with rollover valves
- 15g and 20g include 0-90 Ohm fuel level sending unit
- Standard 12-bolt locking filler cap
- 6gal dimensions: 12" w x 12" l x 10" h
- 15gal dimensions: 18" w x 20" l x 10" h
- 20gal dimensions: 20" w x 24" l x 10" h

**6 GALLON #18659**  
**15 GALLON #18664**  
**20 GALLON #18665**



# PHANTOM

Install a Stealth 340 inside virtually any tank  
**Universal In-Tank Fuel Delivery** see page 10

# 340 TANKS

**High Performance Classic Muscle Car Tanks**  
see page 14

# STEALTH 340 APPLICATION GUIDE



Weather Pack Plug  
pigtail included

**Acura**  
Integra 94-01 #11542  
NSX 91-2000 #11541  
RSX 2002-current #11542

**Chrysler/Dodge/Plymouth**  
FWD 84-90 340 #11540  
Stealth T/T 91-97 #11541  
Eagle Talon 95-98 Turbo #11542  
Eagle Talon 90-94 AWD #11541  
Eagle Talon 90-94 FWD #11542  
Laser 95-98 Turbo AWD & FWD #11542  
Laser 90-94 AWD Turbo #11541  
Laser 90-94 FWD Turbo #11542

**Ford**  
Mustang 85-97 (except Cobra) #11540  
Mustang Cobra 96-97 #11542  
Probe GT 88-92 #11541  
Probe GT 93-97 #11542  
Crown Vic/Marauder 03-04 #11542  
Lightning 99-00 (requires two) #11542  
F150 97-98 #11542  
F150 99-04 #11542

**General Motors**  
Grand National/Regal 182-87 #11569  
Camaro 5.0L & 5.7L 85-92 #11569  
Corvette 5.0L & 5.7L 82-96 #11569  
GM Cars & Trucks 85-92 #11569  
305 (5.0L) & 350 (5.7L) 87-97 #11569  
S10, S15, Sonoma, Blazer, Envoy 82-95 #11569  
Firebird 5.0L & 5.7L 85-92 #11569  
Fiero 2.8L 85-86 #11569  
Cyclone 91-92 #11569  
Typhoon 92-93 #11569  
Saturn SC,SL,SW 97-02 #11542

**Honda**  
Accord 90-93 #11541  
Accord 94-97 #11542  
Accord 98-02 #11542  
Civic 92-2000 #11542  
CRX 89-91 #11541  
Prelude 92-96 #11541  
Prelude 97-01 #11542

**Hyundai**  
Tiburon 97-01 #11542

**Mazda**  
Miata 94-97 #11542  
Miata 99-05 #11542  
MX6 88-92 #11541  
MX6 93-97 #11542  
Protégé 90-91 #11541  
Protégé 95-98 #11542  
RX7 86-88 #11541  
RX7 89-92 #11541  
RX7 93-95 #11541  
323 86-91 #11541

**Mitsubishi**  
3000GT TT 91-97 #11541  
Eclipse 95-98 Turbo #11542  
Eclipse 90-94 AWD #11541  
Eclipse 90-94 FWD #11542  
Galant 85-90 #11542  
\*EVO 8/9 03-07 #11542  
- Factory basket assembly MUST be replaced before converting to a 340 Stealth Pump.  
- Note: If converting to E85, factory basket assembly MUST be modified

**Jeep**  
Wrangler 91-97 #11542  
Wrangler 97-04 #11542  
Cherokee 97-01 #11542  
Grand Cherokee 97-98 #11542

**Lexus**  
GS300 93-2000 #11542  
GS400 92-2000 #11542  
SC300 92-2000 #11542  
SC400 92-2000 #11542

**Nissan**  
D21 Pick Up 86-95 #11542  
200SX 95-98 #11542  
200SX SE-R 95-98 #11542  
240SX 89-94 #11541  
240SX 95-98 #11541  
300ZX 90-96 #11542  
NX1600 91-94 #11541  
NX2000 91-94 #11541  
Sentra 91-94 #11541  
Sentra 98-99 #11542  
Sentra SE 98-99 #11542  
Sentra SE-R 91-94 #11541  
Maxima 84-94 #11541  
Maxima 1998 #11541  
Altima 93-95 #11541  
Altima 96-01 #11542

**Subaru**  
Impreza WRX 98-99 #11541  
Impreza 02-06 #11542  
Impreza WRX/STi 04-07 #11542

**Toyota**  
MR2 91-96 #11541  
Supra 84-92 #11541  
Supra 94-98 #11542  
Supra Turbo 84-92 #11541  
Supra Turbo 94-98 #11541  
T100 93-98 #11542  
Tacoma 95-01 #11542  
Celica 1985-1989 #11541  
Celica 90-93 Turbo AWD #11541  
Celica 90-93 ST & GT #11541  
Corolla 85-92 #11541

# PHANTOM

UNIVERSAL IN TANK SYSTEMS

EFI  
or  
CARB

PATENT NOS. 8,783,287 & 9,567,954

The hottest trend in hot rods and muscle cars today is late model EFI engine swaps and aftermarket EFI systems. It's no secret why; you can make ridiculous power and do it more affordably than ever. What makes these conversions so popular is the ample supply of parts and kits from the aftermarket. Until now, the fuel system has been a costly and time consuming upgrade.

Well...Aeromotive has completely changed the game again. The Phantom Fuel System is a complete kit that gives you everything you need to install a fuel pump and baffle/basket into almost ANY fuel tank. You get an in-tank pump capable of handling serious power even at EFI pressures, a black anodized hanger assembly, and an internal baffle to control fuel slosh and keep the fuel pump submerged. The best part: this entire system is modular. It can be cut to height to fit almost any tank including your stock tank, even tanks as shallow as 6" deep.

- Install an electric fuel pump in any tank
- Sump & baffle combat fuel slosh
- Billet top hat with o-ring boss ports
- Whisper quiet operation
- Excess fuel returns to sump
- Height is adjustable for perfect fit
- Minimizes hot fuel handling issues
- Options for almost any application



## All Kits Include:

- Billet Top Hat with ORB-06 ports
- Foam Baffle & Bladder
- Proprietary Sealing Gasket
- Installation Ring
- High Flow Pre-Pump Filter
- Billet C-Ring Mount
- Height Adjustable Mount 6-11" (12-20" extension kits available)

US Phantom Patent Nos.  
8,783,287  
9,567,954



## PHANTOM 200

200LPH Fuel Pump | Part Number #18689

	Naturally Aspirated	Forced Induction
EFI	600hp	450hp
Carb	750hp	600hp

## PHANTOM 340

340LPH Fuel Pump | Part Number #18688

		Naturally Aspirated	Forced Induction
GAS	EFI	850hp	700hp
	Carb	1,000hp	850hp
E85	EFI	595hp	490hp
	Carb	700hp	595hp

12" - 20" Extension Kit Phantom 200 & 340 - #18788

## NEED MORE PERFORMANCE?

We Have The Perfect Phantom For You >

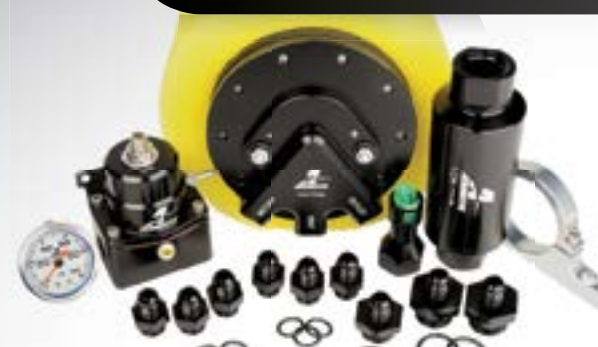

## COMPLETE SYSTEMS

These systems include the following:

- Phantom Fuel System
- Regulator & Gauge
- Fuel Filter
- Premium Wiring Kit
- Appropriate Fittings
- Filter Bracket

Phantom 200

Phantom 340

- Return Style - EFI OEM Rail (3/8" Quick Connect)
- Return Style - EFI Dual Rail (Y-Block)
- Return Style - Carbureted
- Return Style - EFI Conversion/Throttle Body
- Returnless - EFI Conversion/Throttle Body

#17167

#17165

#17255

#17169

#17171

#17166

#17164

#17254

#17168

#17170

## RETURNLESS PHANTOM SERIES

Features an internal valve to set line pressure and eliminate the need for a return line.

EFI Returnless Phantom #18329  
- Features 340lph Fuel Pump  
- Line Pressure set to 60psi  
60psi Valve Only #18703

CARB Returnless Phantom #18201  
- Features 325lph Fuel Pump  
- Line Pressure set to 15psi  
15psi Valve Only #18702



Drill 3.25in hole in the deepest spot of the tank



Use installation ring to locate mount holes



Cut foam 1in TALLER than tank depth



Insert foam inside the tank



Cut hanger 1 in SHORTER than tank depth



Install c-ring, pump, and tighten nuts



WARNING: This product can expose you to chemicals, including chromium, which is known to the State of California to cause cancer or birth defects or other reproductive harm.

# APEX PHANTOM

The Apex Phantom utilizes jet siphon technology to provide a constant supply of fuel to the bladder, allowing the Phantom to thrive in extreme applications like road racing and rock crawling. Another benefit of the jet siphon technology: the Phantom can now be installed in late-model saddle-bag style gas tanks.

Features Jet Siphon Technology To Pick Up Fuel From The Corner Of The Tank Or Saddle Bag

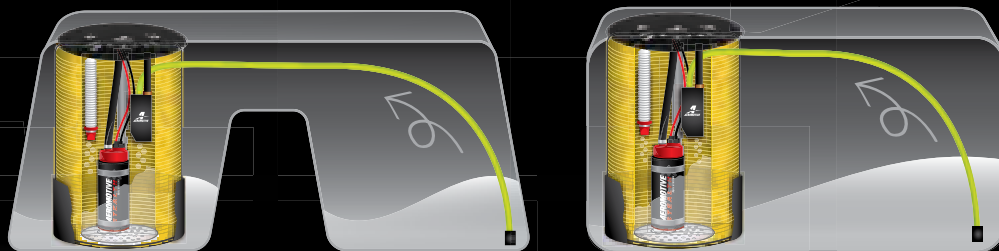

Unique Patent Pending Design Constantly Maintains Siphon Action Even When Air Is Introduced  
Magnetic Tip Keeps Pickup In Desired Location



## Phantom 340 Apex Kit - #18704

	EFI	Naturally Aspirated	Forced Induction
GAS		725hp	595hp
E85		505hp	415hp

## Phantom Flex Apex Kit - #18705

	EFI	Naturally Aspirated	Forced Induction
GAS		975hp	700hp
E85		660hp	485hp

## Jet Siphon Only Kit - #18706

For Use In Fuel Injected Applications Only



## BLADDER BAFFLES TAKE YOUR COLLECTOR TO THE NEXT LEVEL

Optional Valves Eliminate Fuel Starvation in Extreme Applications

- Phantom 200 & 340 includes 4 valves
- Phantom Flex & Dual includes 5 valves
- Trifekta Phantom includes 10 valves

Valves, Gasket & Bladder	Valves & Gasket
#18040	#18020
#18041	#18021
#18042	#18022

# FLEX PHANTOM

## Part Number #18310

- Features 450lph Fuel Pump
- Extra Large Foam and Bladder

		Naturally Aspirated	Forced Induction
GAS	EFI	1,100hp	800hp
	Carb	1,300hp	950hp
E85	EFI	750hp	550hp
	Carb	900hp	700hp

12"- 20" Extension Kit #18710



# DUAL PHANTOM

## Part Number #18309

- Features Two 340LPH Fuel Pumps
- Two Sets of Electrical Terminals

		Naturally Aspirated	Forced Induction
GAS	EFI	1,700hp	1,400hp
	Carb	2,000hp	1,700hp
E85	EFI	1,190hp	980hp
	Carb	1,400hp	1,190hp

12"- 20" Extension Kit #18709



# TRIFEKTA PHANTOM

## Part Number #18311

- Triple 450lph Fuel Pumps
- Larger 6" Billet Cap : Drill 4.5" hole
- ORB-08 Outlet, Vent & Return Ports
- Three Sets of Electrical Terminals
- Main Pump : Auxiliary Pumps : Fuel Level Sending Unit

		Naturally Aspirated	Forced Induction
GAS	EFI	3,300hp	2,400hp
	Carb	3,900hp	2,850hp
E85	EFI	2,250hp	1,650hp
	Carb	2,700hp	2,100hp





WHILE THEY WERE BUSY IMITATING OUR DESIGN,  
WE WERE INNOVATING THE NEXT GENERATION

# GEN III STEALTH TANKS

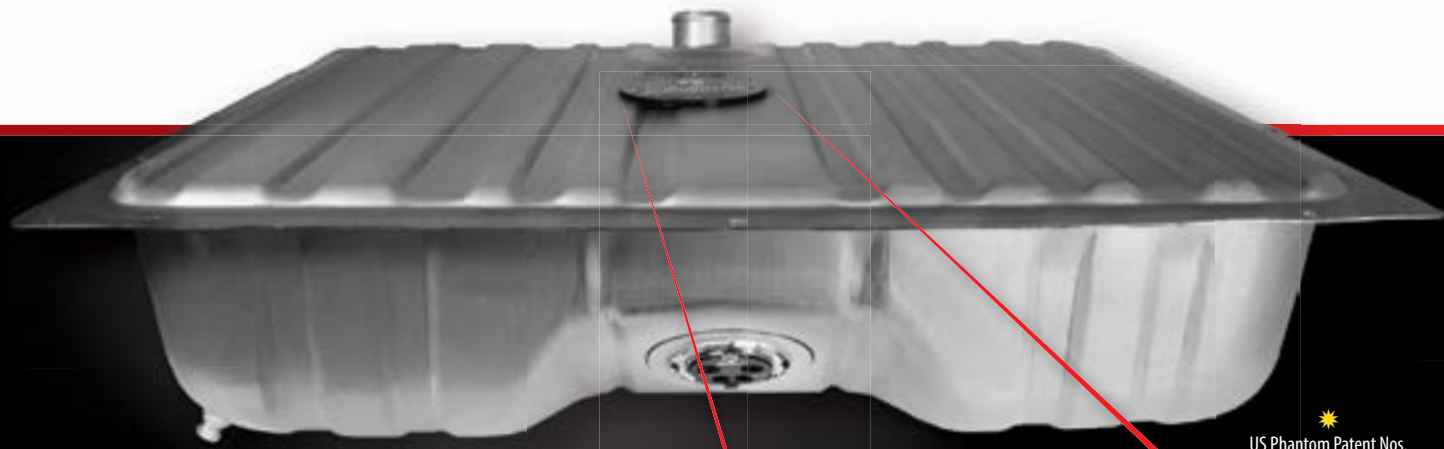

US Phantom Patent Nos.  
8,783,287  
9,567,954

## IT'S WHAT'S INSIDE THAT COUNTS

Everything you need for reliable fuel delivery mounted inside.

- Fuel pump, baffle and fuel level sending unit installed and plumbed to a billet end cap in the factory outlet location
- Available in 200lph or 340lph pumps
- Compatible with Carb or EFI applications



Aeromotive's Patented Phantom Baffle System keeps the fuel pump submerged in fuel at all times.

### UTILIZES OEM FUEL OUTLET LOCATION



Convenient to plumb and mounts flush under your car

### PATENTED & AWARD WINNING PHANTOM TECHNOLOGY

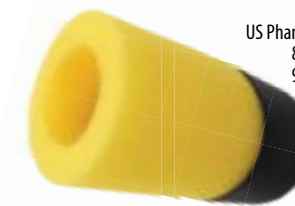

US Phantom Patent Nos.  
8,783,287  
9,567,954

Combats Fuel Starvation: precisely controls fuel around the pump

### PLUG+PLAY NO ASSEMBLY REQUIRED



Fuel Pump, Phantom, Fuel Level Sending Unit, and Fuel Level Float Completely Installed

### APPLICATIONS

64-68	Mustang	18197	18497
69-70	Mustang	18147	18447
71-73	Mustang	18169	18469
60-65	Comet/Falcon	18168	18468
55-57	Chevy	18199	18499
62-65	Chevy II/Nova	18127	18427
66-67	Chevy II/Nova	18131	18431
68-69	Nova	18130	18430
1970	Nova	18133	18433
71-72	Nova	18132	18432
73-74	Nova	18136	18436
75-79	Nova	18137	18437
61-64	Impala	18118	18418
65-66	Impala	18134	18434
70-73	Camaro/Firebird	18128	18428
67-68	Camaro/Firebird	18157	18457
1969	Camaro/Firebird	18158	18458
74-77	Camaro, 74-78 Firebird	18135	18435
78-81	Camaro, 79-81 Firebird	18138	18438
82-92	Camaro	18171	18471
93-97	Camaro	18172	18472
63-67	Corvette	18165	18465
68-69	Corvette	18166	18466
70-74	Corvette	18167	18467
64-67	Chevelle & Malibu	18117	18417
68-69	Chevelle & Malibu	18104	18404
70-72	Chevelle & Malibu, 70 Monte Carlo	18102	18402
71-72	Monte Carlo	18108	18408
78-88	Monte Carlo/Malibu	18151	18451
64-67	Oldsmobile Cutlass	18120	18420
64-67	Buick Skylark	18106	18406
68-69	Olds Cutlass & Buick Skylark	18101	18401
70-72	Cutlass, 70 Skylark	18103	18403
71-72	Skylark, GS & GS 455	18105	18405
81-88	Cutlass, 2 Door	18152	18452
68-70	GTO, LeMans & Grand Prix	18122	18422
71-72	GTO & LeMans	18107	18407
1964	Pontiac GTO	18119	18419
65-67	Pontiac GTO & 66-67 LeMans	18121	18421
1965	Pontiac LeMans	18124	18424
78-87	Buick Regal	18149	18449
73-81	Chevy 1/2 ton Truck (short wheel base)	18170	18470
64-65	Polara	18163	18463
66-67	GTX Charger	18164	18464
68-70	Road Runner/Satellite/70 Super Bird	18173	18473
68-70	Charger	18159	18459
1970	Road Runner	18160	18460
68-69	Dart	18161	18461
70-74	Challenger	18142	18442
70-74	Barracuda	18143	18443
70-76	Dart/Duster	18144	18444
71-72	Charger Road Runner	18162	18462

### 200LPH 340LPH

18197	18497
18147	18447
18169	18469
18168	18468
18199	18499
18127	18427
18131	18431
18130	18430
18133	18433
18132	18432
18136	18436
18137	18437
18118	18418
18134	18434
18128	18428
18157	18457
18158	18458
18135	18435
18138	18438
18171	18471
18172	18472
18165	18465
18166	18466
18167	18467
18117	18417
18104	18404
18102	18402
18108	18408
18151	18451
18120	18420
18106	18406
18101	18401
18103	18403
18105	18405
18152	18452
18122	18422
18107	18407
18119	18419
18121	18421
18124	18424
18149	18449
18170	18470
18163	18463
18164	18464
18173	18473
18159	18459
18160	18460
18161	18461
18142	18442
18143	18443
18144	18444
18162	18462



## 200LPH

	Naturally Aspirated	Forced Induction
EFI	600hp	450hp
Carb	750hp	600hp

## 340LPH

	Naturally Aspirated	Forced Induction	
GAS	EFI	850hp	700hp
	Carb	1,000hp	850hp
E85	EFI	595hp	490hp
	Carb	700hp	595hp

**WARNING:** This product can expose you to chemicals, including chromium, which is known to the State of California to cause cancer or birth defects or other reproductive harm.

**WARNING:** This product can expose you to chemicals, including chromium, which is known to the State of California to cause cancer or birth defects or other reproductive harm.

# A1000

FAMILY OF PRODUCTS

GAS	Naturally Aspirated	Forced Induction
Fuel Injected	1,300hp	1,000hp
Carbureted	1,500hp	1,200hp

E85	Naturally Aspirated	Forced Induction
Fuel Injected	910hp	700hp
Carbureted	1,050hp	840hp

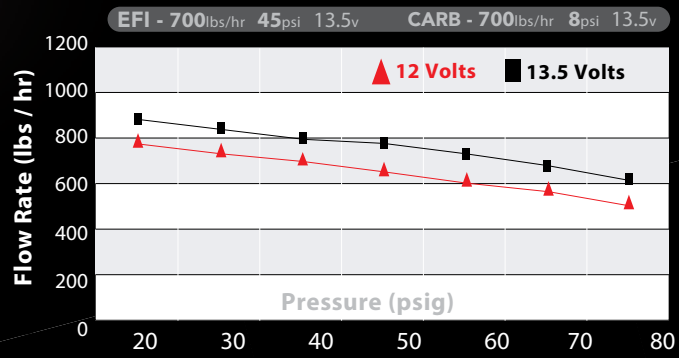

# A1000

## STEALTH PUMP MODULES

- Features ORB outlet and return ports
- Incorporates factory jet siphon system and sending unit
- Includes an integrated 100 micron stainless steel pre-pump filter
- Utilizes the factory tank, o-ring, lock ring and mounting location
- Requires the use of a bypass-style regulator and return line.
- Billet Speed Pump Controller (#16306) required for EFI street applications.

### Systems Include:

- In Tank Stealth Fuel Pump,
- Filter and Fuel Rails
- ORB fittings
- Pump Speed Controller (#16306) or Wiring Kit (#16307)



## A1000 EXTERNAL

#11101



- ORB-10 inlet and outlet ports.
- For EFI applications use regulator #13101 or #13303
- For carb applications use regulator #13204 or #13304
- Fully submersible for custom, in-tank placement.
- Perfect for 'blow-through' carbureted engines up to 1200hp.
- Speed Pump Controller (#16306) recommended for EFI street applications.

**RED #11101    PLATINUM #11151**  
**MARINE #11108**

**SYSTEMS** Includes: Filters, regulator, port fittings, stainless steel braided hose, hose-ends, wiring and installation hardware.

#17125 : EFI System with 11101 & 13101 Regulator  
#17242 : Carb System, with 11101 & 13204 Regulator

## NEW BRUSHLESS A1000

**SIGNATURE**  
#11183  
VARIABLE SPEED  
#11193



{ AVAILABLE JULY 2019 }

**ROUND**  
#11124  
VARIABLE SPEED  
#11189

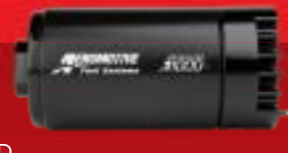

{ AVAILABLE JULY 2019 }

## A1000 FUEL CELLS

These aluminum Stealth fuel cells are available in 6, 15 or 20 gallon size and fitted with the legendary A1000 fuel pump. Unlike conventional fuel cells, the Stealth Cells feature innovative baffling inside and an in-tank fuel pump with pre-pump fuel filter. Whether it's drifting, the weekend autocross, or a date with the drag strip, these fuel cells perform unlike anything you've seen. In fact, the Aeromotive Stealth Fuel Cells are the OE fuel system for the Ford Cobra Jet Mustang, the Chevrolet COPO Camaro, and the Mopar Drag Pak Challenger. If they can fuel these record-setting factory hot rods and meet the strict standard of the Big 3, surely they can fuel your ride.

- Features (x1) ORB-10 outlet and (x1) AN-08 return
- Includes (x2) AN-08 vents with rollover valves
- 15 and 20 gallon include 0-90 Ohm fuel level sending unit
- Standard 12-bolt locking filler cap

- 6 gal dimensions: 12" w x 12" l x 10" h
- 15 gal dimensions: 18" w x 20" l x 10" h
- 20 gal dimensions: 20" w x 24" l x 10" h

	TRADITIONAL	BRUSHLESS	VARIABLE SPEED BRUSHLESS
6GAL	#18666	#18366	#18386
15GAL	#18660	#18360	#18380
20GAL	#18661	#18361	#18381

{ AVAILABLE JULY 2019 }



INTERNALLY BAFFLED

## FUEL CELL MODULES

Direct Drop-In For Any Aeromotive Fuel Cell, including Cobra Jet, COPO & Drag Pak Cells. Also available for custom built cells.

	TRADITIONAL	BRUSHLESS	VARIABLE SPEED BRUSHLESS
<b>UNIVERSAL - Height Adjustable 10-16in</b>	#18668	#18368	#18388
<b>DROP IN - For 10in Tall Fuel Cells</b>	#18003	#18023	#18043
<b>PUMP ONLY - Replacement Module</b>	#18010		

{ AVAILABLE JULY 2019 }

## All A1000 kits feature ORB-08 outlet and ORB-08 return ports

**COBRA 2003-04**  
- Pump #18679  
- System & Wiring Kit #17188  
- System & Pump Speed Controller #17189

**GT 2005-09**  
- Pump #18676  
- System & Wiring Kit #17302  
- System & Pump Speed Controller #17303

**GT500 2007-12**  
- Pump #18682  
- System & Wiring Kit #17312  
- System & Pump Speed Controller #17313

**GT 2010-13**  
- Pump #18694  
- System & Wiring Kit #17324  
- System & Pump Speed Controller #17325



## Fox Body Mustang Tank

- #18685 86 - 98.5 A1000 Fox Body Stealth Fuel Tank Assembly
- #18690 86 - 98.5 Fox Body Stealth Tank Only
- #17130 86 - 95 5.0L Mustang A1000 Stealth System

## MUSTANG



## CAMARO 2010-2015

## A1000 CAMARO MODULE - PART NUMBER 18673

The Camaro Stealth Pump is a complete drop-in single fuel pump assembly for 2010 and later Camaros. This pump is available as a single A1000 or Eliminator that drops right into your factory tank, while still incorporating the factory jet siphon system. Now with a true return-style system in your Camaro, you can support the power you're making while retaining your factory fuel tank

## ORB-08 outlet and ORB-08 return ports

**A1000 & Wiring Kit**  
with LS3 #14115 Rails: #17192

**A1000 & Pump Speed Controller**  
with LS3 #14115 Rails: #17193



## CORVETTE 2003-2013

## A1000 CORVETTE MODULE Part Number 18670

Finally, a solution to your Corvette's fuel system needs. Simple single pump system with no more complicated surge tanks. Aeromotive has engineered a patented, complete drop-in fuel pump available for C6 and late C5 Corvettes.



**A1000 & Wiring Kit**  
with LS1 #14106 Rails: #17172  
with LS2 #14114 Rails: #17174  
with LS3 #14115 Rails: #17176  
with LS7 #14142 Rails: #17178

**A1000 & Speed Controller**  
with LS1 #14106 Rails: #17173  
with LS2 #14114 Rails: #17175  
with LS3 #14115 Rails: #17177  
with LS7 #14142 Rails: #17179

# ELIMINATOR

## FAMILY OF PRODUCTS

GAS	Naturally Aspirated	Forced Induction
Fuel Injected	1,900hp	1,400hp
Carbureted	2,300hp	1,700hp

E85	Naturally Aspirated	Forced Induction
Fuel Injected	1,330hp	980hp
Carbureted	1,610hp	1,190hp

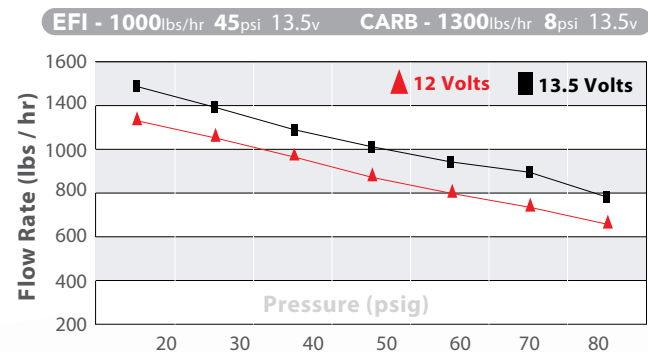

## EXTERNAL

- ORB-12 inlet port and ORB-10 outlet port
- EFI applications use regulator #13134 or #13305
- Carbureted applications use regulator #13212 or #13202
- Fully submersible for custom, in-tank placement
- Perfect for "blow-through" carbureted engines up to 1,700hp
- Speed Pump Controller (#16306) required for street applications

### BLACK #11104

### MARINE #11110

**SYSTEMS** Includes: Filters, regulator, port fittings, stainless steel braided hose, hose-ends, wiring and installation hardware.

#17126 : EFI System with 11104 & 13101 Regulator



#11104

## NEW BRUSHLESS ELIMINATOR

### SIGNATURE

#11183  
VARIABLE SPEED  
#11193

{ AVAILABLE JULY 2019 }



### ROUND

#11124  
VARIABLE SPEED  
#11189

{ AVAILABLE JULY 2019 }

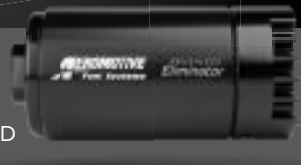

## FUEL CELLS

These aluminum Stealth fuel cells are available in 6, 15 or 20 gallon size and fitted with the legendary Eliminator fuel pump. Unlike conventional fuel cells, the Stealth Cells feature innovative baffling inside and an in-tank fuel pump with pre-pump fuel filter. Whether it's drifting, the weekend autocross, or a date with the drag strip, these fuel cells perform unlike anything you've seen. In fact, the Aeromotive Stealth Fuel Cells are the OE fuel system for the Ford Cobra Jet Mustang, the Chevrolet COPO Camaro, and the Mopar Drag Pak Challenger. If they can fuel these record-setting factory hot rods and meet the strict standard of the Big 3, surely they can fuel your ride.

- Features (x1) ORB-10 outlet and (x1) AN-08 return
- Includes (x2) AN-08 vents with rollover valves
- 15g and 20g include 0-90 Ohm fuel level sending unit
- Standard 12-bolt locking filler cap

- 6g dimensions: 12" w x 12" l x 10" h
- 15g dimensions: 18" w x 20" l x 10" h
- 20g dimensions: 20" w x 24" l x 10" h

	TRADITIONAL	BRUSHLESS	VARIABLE SPEED BRUSHLESS
6GAL	#18667	#18368	#18387
15GAL	#18662	#18362	#18382
20GAL	#18663	#18363	#18383

{ AVAILABLE JULY 2019 }

VARIABLE SPEED BRUSHLESS



INTERNALLY BAFFLED

## FUEL CELL MODULES

Direct Drop-In For Any Aeromotive Fuel Cell, including Cobra Jet, COPO & Drag Pak Cells. Also available for custom built cells.

	TRADITIONAL	BRUSHLESS	VARIABLE SPEED BRUSHLESS
UNIVERSAL - Height Adjustable 10-16"	#18669	#18369	#18389
DROP IN -10" Tall Fuel Cells	#18004	#18024	#18044
PUMP ONLY - Replacement Module	#18011		{ AVAILABLE JULY 2019 }

⚠ WARNING : This product can expose you to chemicals, including chromium, which is known to the State of California to cause cancer or birth defects or other reproductive harm.

# ELIMINATOR

## STEALTH PUMP MODULES

- Features ORB outlet and return ports
- Incorporates factory jet siphon system and sending unit
- Includes an integrated 100 micron stainless steel pre-pump filter
- Utilizes the factory tank, o-ring, lock ring and mounting location
- Requires the use of a bypass-style regulator and return line.
- Billet Speed Pump Controller (#16306) required for EFI street applications.

### Systems Include:

- In Tank Stealth Fuel Pump,
- Filter and Fuel Rails
- ORB fittings
- Pump Speed Controller (#16306) or Wiring Kit (#16307)

## All Eliminator kits feature ORB-08 outlet and ORB-08 return ports

**COBRA 2003-04**  
- Pump #18680  
- System & Wiring Kit #17190  
- System & Pump Speed Controller #17191

**GT 2005-09**  
- Pump #18677  
- System & Wiring Kit #17326  
- System & Pump Speed Controller #17327

**GT500 2007-12**  
- Pump #18683  
- System & Wiring Kit #17336  
- System & Pump Speed Controller #17337

**GT 2010-13**  
- Pump #18695  
- System & Wiring Kit #17348  
- System & Pump Speed Controller #17349



### Fox Body Mustang Tank

- #18686 86 - 98.5 Eliminator Fox Body Stealth Fuel Tank Assembly
- #18690 86 - 98.5 Fox Body Stealth Tank Only
- #17131 86 - 95 5.0L Mustang Eliminator Stealth System

## MUSTANG



## CAMARO 2010-2015

### ELIMINATOR CAMARO MODULE - PART NUMBER 18674

The Camaro Stealth Pump is a complete drop-in single fuel pump assembly for 2010 and later Camaros. This pump is available as a single A1000 or Eliminator that drops right into your factory tank, while still incorporating the factory jet siphon system. Now with a true return-style system in your Camaro, you can support the power you're making while retaining your factory fuel tank

### ORB-08 outlet and ORB-08 return ports

**Eliminator & Wiring Kit**  
with LS3 #14115 Rails: #17194

**Eliminator & Pump Speed Controller**  
with LS3 #14115 Rails: #17195



## CORVETTE 2003-2013

### ELIMINATOR CORVETTE MODULE Part Number 18671

Finally, a solution to your Corvette's fuel system needs. Simple single pump system with no more complicated surge tanks. Aeromotive has engineered a patented, complete drop-in fuel pump available for C6 and late C5 Corvettes.

**Eliminator & Wiring Kit:**  
with LS1 #14106 Rails: #17180  
with LS2 #14114 Rails: #17182  
with LS3 #14115 Rails: #17184  
with LS7 #14142 Rails: #17186

**Eliminator & Speed Controller:**  
with LS1 #14106 Rails: #17181  
with LS2 #14114 Rails: #17183  
with LS3 #14115 Rails: #17185  
with LS7 #14142 Rails: #17187

⚠ WARNING : This product can expose you to chemicals, including chromium, which is known to the State of California to cause cancer or birth defects or other reproductive harm.

# PRO-SERIES

Designed for serious horsepower, its hard to find a more powerful, higher flowing, in-line fuel pump anywhere. Engineered for high-horsepower racing engines, this beautiful pump features our innovative 'dual chamber' pump design.

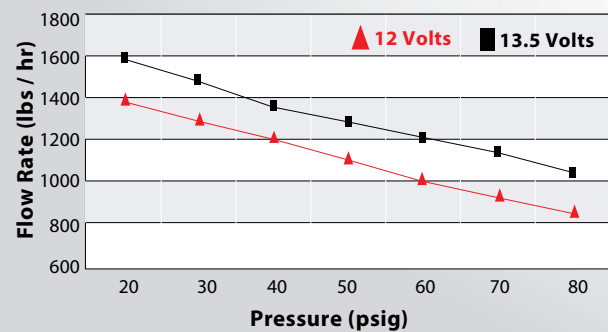

GAS	Naturally Aspirated	Forced Induction
Fuel Injected	2,200hp	1,700hp
Carbureted	2,600hp	2,000hp

E85	Naturally Aspirated	Forced Induction
Fuel Injected	1,540hp	1,190hp
Carbureted	1,820hp	1,400hp

EFI - 1200lbs/hr 45psi 13.5v CARB - 1500lbs/hr 8psi 13.5v

## EXTERNAL

- ORB-12 inlet and outlet ports
- New Black Hard Coat Anodized finish
- Includes two ORB-12 to AN-12 fittings
- Perfect for "blow-through" carbureted engines up to 2,000hp
- Fully submersible for custom, in-tank placement
- Speed Pump Controller (#16306) required for limited street driving
- EFI applications use regulator #13110 or #13134
- Carb applications use regulator #13212 or #13202

PART NUMBER  
**11102**



## FUEL CELL

- Features (x1) ORB-10 outlet and (x1) AN-08 return
- Includes (x2) AN-08 vents with rollover valve
- Standard 12-bolt locking filler cap
- Dimensions: 12"w x 12"l x 10"h

6 GALLON  
**#18645**



## FUEL CELL MODULES

**#18005 - PRO-SERIES IN-TANK PUMP & FILTER**  
DIRECT DROP IN FOR 10" FUEL CELLS

**WARNING:** This product can expose you to chemicals, including chromium, which is known to the State of California to cause cancer or birth defects or other reproductive harm.

# BRUSHLESS GEARPUMPS

Engineered from the ground up to be capable of today's extreme flow demands, while also sustaining that flow at high pressures.

- Extended Life
- Higher Efficiency
- Lower Current Draw
- Less Heat

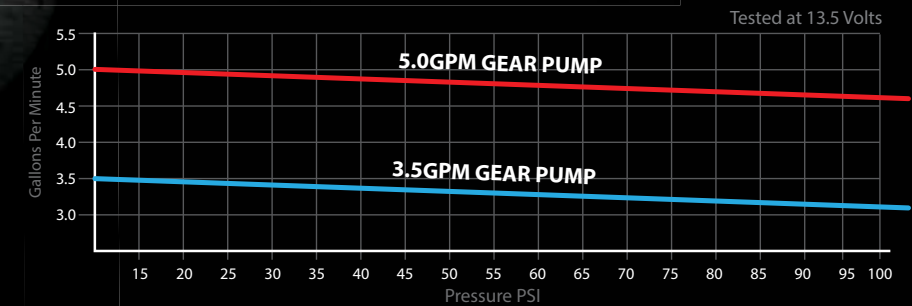

**3.5GPM**

GAS	Naturally Aspirated	Forced Induction
Fuel Injected	2,400hp	1,800hp
Carbureted	2,600hp	2,000hp

E85	Naturally Aspirated	Forced Induction
Fuel Injected	1,680hp	1,260hp
Carbureted	1,820hp	1,400hp

**5.0GPM**

GAS	Naturally Aspirated	Forced Induction
Fuel Injected	3,400hp	2,600hp
Carbureted	3,600hp	2,700hp

E85	Naturally Aspirated	Forced Induction
Fuel Injected	2,380hp	1,820hp
Carbureted	2,520hp	1,890hp

## EXTERNAL

- ORB-12 inlet and ORB-10 outlet ports
- Extended service life in methanol and ethanol
- New integral spur-gear pumping mechanism
- 90 psi continuous operating pressure and up to 150 psi peak pressure, base plus boost
- Integral, external brushless controller for clean installation, cooler fuel and enhanced reliability



CONFIGURATION	3.5GPM		5.0GPM	
	STANDARD	VARIABLE	STANDARD	VARIABLE
ROUND	#11181	#11191	#11182	#11192
SIGNATURE	#11185	#11194	#11186	#11196

{ TRUE VARIABLE SPEED AVAILABLE JULY 2019 }

## FUEL CELLS

- Features (x1) ORB-10 outlet and (x1) AN-08 return
  - Includes (x2) AN-08 vents with rollover valves
  - 15g and 20g include 0-90 Ohm fuel level sending unit
  - Standard 12-bolt locking filler cap
- { TRUE VARIABLE SPEED AVAILABLE JULY 2019 }

Dimension :	CAPACITY	3.5GPM		5.0GPM	
		STANDARD	VARIABLE	STANDARD	VARIABLE
• 6 gal : 12"w x 12"l x 10"h	6 GAL	#18376	#18396	#18377	#18397
• 15 gal : 18"w x 20"l x 10"h	15 GAL	#18370	#18390	#18372	#18392
• 20 gal : 20"w x 24"l x 10"h	20 GAL	#18371	#18391	#18373	#18393

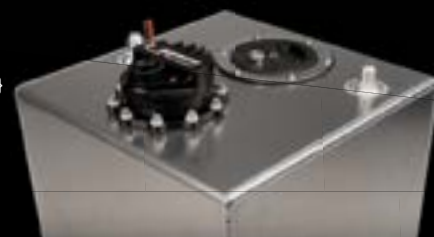

## FUEL CELL MODULES

{ TRUE VARIABLE SPEED AVAILABLE JULY 2019 }

	3.5GPM		5.0GPM	
	STANDARD	VARIABLE	STANDARD	VARIABLE
<b>UNIVERSAL</b> ADJUSTABLE 10-16"	#18374	#18394	#18375	#18395
<b>DROP-IN</b> FIXED 10" MODULE	#18025	#18045	#18026	#18046

For Any Aeromotive Fuel Cell, including Cobra Jet, COPO & Drag Pak Cells.

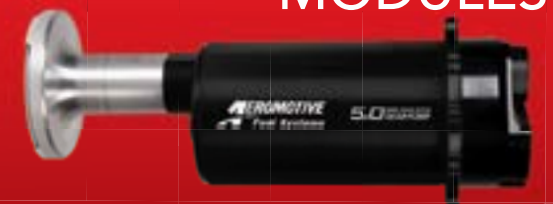

**WARNING:** This product can expose you to chemicals, including chromium, which is known to the State of California to cause cancer or birth defects or other reproductive harm.



# HIGH OUTPUT

This pump is ideal for carbureted power plants that are capable of handling 7 psi, without using a separate fuel pressure regulator. The H/O Fuel Pump is designed for engines making 200-600hp and is ideal for street cars and mild race cars alike. Similar to our SS Fuel Pump (#11203), but internally regulated to 7 psi.

**ORB-08 #11219** **3/8" NPT #11203**

- Durable billet construction
- Fuel flow exceeds 90 GPH at 5 psi and draws less than 5 amps
- Internally regulated to 7 psi, eliminating the need for a separate regulator on most carbs
- Rated for continuous duty, the pumping mechanism features a composite rotor, stainless steel vanes, and heat-treated steel top and bottom plates for durability

#17245 : H/O Carbureted Pump System (#11209)  
filters, plumbing, wiring and installation kit

# SS SERIES

This SS Series carbureted fuel pump allows you to step up your performance by maintaining optimal line pressure and delivering high volume. The Street/Strip Pump was engineered for 200-750hp carbureted engines making this a perfect choice for a daily driver, street rod or demanding ET-bracket race car.

**ORB-08 #11213** **3/8" NPT #11203**

- Fuel flow exceeds 140 GPH at 13.5 volts. Supports 200-500hp
- Perfect for use with either a Bypass Regulator (#13301) or one of our Carbureted Adjustable Regulators. (#13201, #13205)
- Pump provides 14 psi of fuel pressure - perfect for cars that leave hard
- Pumping mechanism features our proprietary composite rotor, stainless steel vanes and precision ground, heat treated steel plates
- Ideal for dedicated nitrous delivery
- E85 and Alcohol compatible
- Low current draw. (under 5 amps)

#17201 : SS Complete System  
#11203 Fuel Pump and #13201 Regulator

The following systems include filters, plumbing, wiring and installation kit.

#17122 SS Pump Kit (#11203)  
#17246 SS Pump (#11203) & Regulator (#13205)  
#17247 SS Pump (#11213) & Regulator (#13201)



# A2000 #11202

From Stock Eliminator to Pro Mod, the Aeromotive A2000 has proven to be the most versatile "big" carbureted fuel pump on the planet. The A2000 flows enough fuel to support the world's quickest nitrous Pro Mods on gasoline. It is the industry's only fuel pump that uses a true diaphragm controlled adjustable bypass valve, integral to the pump. This design dampens pressure spikes, which delivers smoother, more controlled flow and pressure, and ensures more consistent E.T.s and win lights.

- High torque, low RPM motor design delivers 350 GPH free flow at less current draw than any other pump in its class
- Supports up to 2,500hp gasoline, and up to 1,500hp methanol
- Adjustable diaphragm bypass valve outperforms ineffective poppet designs, which minimizes flow loss and pressure fluctuation to the regulator and carburetor
- ORB-10 inlet and outlet ports with ORB-08 return and 1/8" NPT gauge port
- Proprietary seal design eliminates leakage
- Multiple bolt patterns on the bottom of the pump body fit many mounting options
- Ethanol, Methanol compatible

#17202 A2000 Pump Kit (#11202)  
filters, plumbing, wiring and installation kit

#17203 : A2000 System (single Carb)  
#11202 Fuel Pump and #13201 Regulator  
#17204 : A2000 System (dual Carb)  
#11202 Fuel Pump and #13203 Regulator



# A3000

Compact, High Flow  
100-micron Stainless  
Steel Pre-Filter



15% more flow across the entire pressure range  
**6.8 gpm @ 5 psi / 13.5V**  
(Over 400 gph)  
**7.8 gpm @ 5 psi / 16V**  
(Over 460 gph)

Best Pressure Control of any fuel pump in its class.

Line Pressure Adjustable from 12-28 psi  
Preset at 18 psi

**Modular Design**  
Separate or Rotate Components for Optimal Mounting Clearance

# EXTREME CARBURETED DRAG PUMP

The A3000 Fuel Pump is an upgrade of one of the winningest fuel pumps in drag racing: the popular A2000 Fuel Pump. The A3000 shares the same basic design and function as its predecessor, but boasts greater efficiency, less weight, and over 1 GPM more flow at pressure and never-before-seen modular features and mounting options, like a removable and indexable fuel filter and true diaphragm-controlled bypass regulator.

- Supports up to 3,000hp on gasoline, and up to 2,000hp on methanol
- True diaphragm controlled bypass regulator integrated into the pump, for 14-28 psi line pressure
- Regulator provides smoother and more controlled flow and pressure as well as dampens pressure spikes
- The new A3000 design allows for the regulator and integrated filter to be clocked in 45° increments
- Regulator can be removed and run as a true bypass regulator
- Regulator's bolt pattern matches up to the Aeromotive Stackable Regulators (#13217) allowing the best in pressure control and nitrous fuel system solutions
- 15% more flow across the entire pressure range (vs. the A2000)
- New light weight design (5.1 lbs total)
- ORB-12 inlet and ORB-10 outlet
- Alcohol/Methanol/E85 compatible

# PART NUMBERS

- #11215 – A3000 Complete Kit (pump, regulator, & filter)
- #11216 – A3000 Carbureted Fuel Pump
- #11217 – A3000 Pressure Regulator
- #11218 – A3000 100-Micron Fuel Filter
- #11222 – A3000 Fuel Pump & Regulator (does not include filter)



# SPUR GEAR

## EXTREME CUSTOM PUMPS



- Flow Ratings from **16 GPM to 32 GPM**
- Variety of hose attachments
- Complete line of distribution blocks and shut off valves
- Mount with 3 or 4 bolt flange or V-band
- NHRA Certifiable



The Aeromotive Spur Gear pump is the largest gear pump in the Aeromotive family. This pump features a contoured and coated body, thrust plates, & gear sets to reduce cavitation and increase longevity. From Nostalgia Funny Car to countless Pro Mod cars, this new spur gear pump has undergone extreme testing. These relationships as well as serious research and development ensure the utmost performance and reliability under the harshest environments. Built to the strictest of standards, these pumps are sure to live up to everything you expect from Aeromotive products. Available in a complete range of flow ratings, and NHRA certifiable options.

The Aeromotive Spur Gear line offers an assortment of inlet and outlet attachments, as well as three different sized distribution blocks to ensure proper plumbing and configuration. Mount with either a 3 or 4 bolt flange or a V-band adapter.

**WE DO  
RESEARCH &  
DEVELOPMENT  
AT 250MPH**



### Custom Made Pumps

Gallons Per Minute	Shaft	Fuel	Part #
16	.375	Gas/Alcohol	#11134
16	.375	Nitro	#11934
16.75	.375	Gas/Alcohol	#11152
17	.375	Gas/Alcohol	#11172
18	.375	Gas/Alcohol	#11148
19.5	.375	Gas/Alcohol	#11130
19.5	.375	Nitro	#11930
21.5	.375	Gas/Alcohol	#11132
21.5	.375	Nitro	#11932
25	.375	Gas/Alcohol	#11138
25	.375	Nitro	#11938
32	.375	Gas/Alcohol	#11143
32	.375	Nitro	#11943

### Certifiable

NHRA Nostalgia Dragster		
20gpm	.375 shaft	#11937
NHRA Nitro Nostalgia Funny Car		
21gpm	.375 shaft	#11936

### Pre-Certified

NHRA Nostalgia Dragster		
20gpm	.375 shaft	#11941
NHRA Nitro Nostalgia Funny Car		
21gpm	.375 shaft	#11940

\* Also Available in 7/16" Hex Shaft  
\*\* Also Available in Steel Bodies

### Inlet / Outlet



AN-20 Flare  
#11732



1.25 Hose #11730  
1.50 Hose #11731  
1.75 Hose #11749  
2.00 Hose #11750



AN-08 Port #11751  
AN-10 Port #11733  
AN-12 Port #11734  
AN-16 Port #11752

### Distribution



AN-06 Ports #11738  
AN-08 Ports #11739  
AN-10 Ports #11740

#### Shut Off Valves (AN-8)

Left #11741  
Right #11742  
Left Nitro #11743  
Right Nitro #11744

### Mounts



3 or 4 Bolt Flange  
#11736



V-Band Adapter #11735  
V-Band Clamp #11737

# SIX GALLONS PER MINUTE GEROTOR

Zero amperage draw, less weight, and more flow! The Six Series Belt Drive Fuel Pump was designed to solve fuel delivery problems in high horsepower, forced-induction EFI applications, as well as the now popular, carbureted applications on gas or methanol.

**BELT DRIVE #11105**  
**HEX DRIVE #11107**

- Supports up to 3600hp gas, 1800hp methanol
- Compact size facilitates easy mounting
- Billet aluminum CNC-machined body, not "cast"
- ORB-10 inlet and outlet ports
- For EFI applications use regulator #13113
- Carbureted gasoline applications require regulator #13202 or #13212
- Alcohol applications require Double Adjustable Regulator #13209 or #13214
- Bracket and Cog Pulley sold separately

**#17140 Kit Includes:**  
**Pump, Bracket and Pump Pulley**

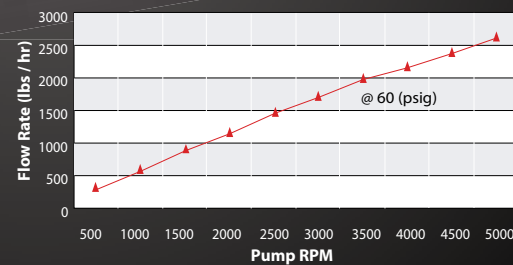

## BB CHEVY BELT DRIVE #17241

This kit can produce anywhere from 2-200 psi with enough volume to support 2500hp from your big block Chevy. Includes our Belt Drive Fuel Pump capable of producing high volume and supports high or low pressure whether it's fuel injected (electric or mechanical), carbureted, blown, turbocharged or nitrous assisted.

- Kit includes: Six Series Belt Drive Fuel Pump (#11105), BBC drive mandrel, pump pulley, crank pulley, cog belt, BBC mounting bracket, adjustment shims & hardware
- Designed for lower left mounting. Must modify for right-hand mounting
- EFI applications use Aeromotive Regulator #13113 (sold separately)
- Carbureted Gasoline : use Regulator #13202 or #13212 (sold separately)
- Carbureted Alcohol : use Regulator #13209 or #13214 (sold separately)

**#17243** System with Double Adjustable Regulator (#13209)  
Designed for alcohol carbureted cars



## ACCESSORIES



Billet BBC Drive Mandrel  
**#21106**



28 Tooth Cog Belt Pulley  
3/8" Pitch : **#21109**



14 Tooth Cog Belt Pulley  
3/8" Pitch, 1" ID : **#21108**



Timing Belt - 1/2" wide Neoprene  
w/ fiberglass cord, 60 groove (22.5")  
L pitch (.375") : **#21110**



# TWELVE GALLONS PER MINUTE GEROTOR

Designed to feed monster EFI and Carbureted engines on gasoline or alcohol. This 12 gpm Belt Drive Pump is engineered to be driven by a pulley or cog drive which allows you to drive the pump from your crankshaft or camshaft. It can be used in both high or low-pressure applications.

**BELT DRIVE #11115**  
**HEX DRIVE #11117**

- Flows in excess of 4,000 lbs/hr (over 11 GPM at 100 psi)
- Supports over 7,000hp gas and 2,500hp methanol
- Type III hard coat anodize protects the 6061 T6 aircraft aluminum alloy housing
- Features removable 1.25" and AN-16 inlet, and ORB-12 outlet
- EFI applications require regulator #13113, #13132, or #13133
- Belt Drive Bracket (#11706) and Cog Pulley (#21109) see below
- Hex Drive option includes collar for standard three bolt pattern

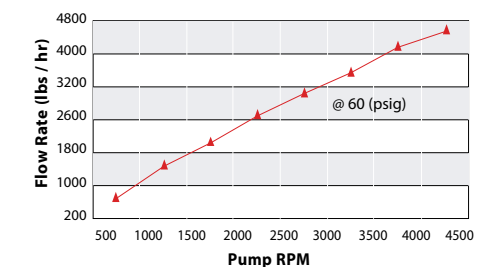

## PRIMING PUMP #11109

- Universal inline pump, designed for external mounting
- Rated for continuous duty applications
- Flows 300 lbs. per hour @ 13.5 Volts and 45 psi
- 5/16" hose barb inlet and outlet are standard
- Suitable for use with Aeromotive Digital FMU #16303
- AN-08 adapter fitting #15114 must be used in stand alone applications (sold separately)



## PRIMING PUMP KIT #17301

- In line EFI Fuel Pump (#11109)
- AN-08 inlet and AN-06 outlet pump adapter fittings
- ORB-10 male / ORB-06 female adapter
- Stainless Steel Braided AN hose
- All ORB fittings and AN hose ends
- Fuel Pump Wiring Kit and complete installation instructions



**BELT DRIVE BRACKET WITH DRIVE**  
PASSENGER SIDE #11708      DRIVER SIDE #11707



Straight Billet Bracket for  
#11105, #11115 Fuel Pumps  
**#11704**



Billet Fuel Pump Bracket  
#11105 Fuel Pump **#11705**  
#11115 Fuel Pump **#11706**

# AEROMOTIVE DIESEL LIFT PUMP

**MORE RELIABLE | MORE EFFICIENT**

Aeromotive has announced that its superior fuel system technology is now available to the diesel performance enthusiast. After years of product development, Aeromotive offers a pump that will outlast and out-perform the competition. Forget everything you know about diesel lift pumps - Aeromotive has once again advanced fuel delivery technology.

The Aeromotive diesel lift pump has the flow to fuel the most aggressive diesels. This is our first pump aimed directly at the diesel market; however, we are no strangers to it. Performance diesel enthusiasts have been using Aeromotive's in-line and t-style pumps for decades. This diesel lift pump is available as either a pump-only, or in vehicle specific kit form.

The Aeromotive diesel lift pump was developed to solve some key issues in the diesel lift pump market. Most notably, it solves the 1/4-tank issue, the pressure control issue, and motor shaft seal failures. Aeromotive opted for a flow-through wet motor, completely eliminating the shaft seal and ensuring that leaking seals are a thing of the past. Specific to the Duramax platform is a "fail safe" valve. In the event of electrical failure or a no-run condition, the valve will allow the injection pump to draw fuel through the lift pump. This insures the vehicle will continue to run, getting you to your destination and eliminating expensive tow bills. With a brushless motor design, Aeromotive has increased the performance and longevity you would expect from a diesel lift pump. A single filter model simplifies the design and reduces maintenance cost. Our diesel pump includes the Caterpillar 1R-0750 2-micron filter to catch the smallest particulates. With a standard 1"-14 filter head thread, the end user can use their filter of choice.

- #11802 – Performance Street Pump (130gph flow rate)
- #11806 – Extreme Performance Pump (230gph flow rate)

## 01-10 Chevy Duramax

- #11801 – Complete Kit 130gph @10psi
- #11811 – Complete Kit 230gph @10psi

## 03-07 Ford Powerstroke

- #11808 – Complete Kit 130gph @10psi

## 08-10 Ford Powerstroke

- #11807 – Complete Kit 130gph @10psi
- #11817 – Complete Kit 230gph @10psi

- #11803 – Duramax Retrofit Kit : replaces existing aftermarket lift pumps
- #11804 – Fuel line & wiring kit
- #11805 – Baffled pick up kit (5/8" feed line)



### BRUSHLESS MOTOR

The latest brushless motor technology reduces current draw by 33% and offers more than double the service life of the traditional style brushed motors.



### TRUE DIAPHRAGM ADJUSTABLE REGULATOR

An engineered solution designed to provide the best pressure control and flow at volume.



### CAT® FUEL FILTER (1R-0750)

2 Micron : Saves wear and tear on injectors and injection pumps.  
Standard 1"-14 filter head thread

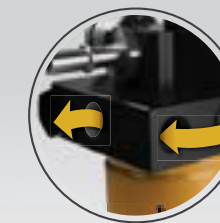

### OPTIONAL HEATER PORTS

These ports allow the customer to plumb engine coolant to the fuel pump block to keep the unit from freezing up in extreme conditions.



### FUEL PRESSURE GAUGE

This allows the end user to dial in their desired fuel pressure with accuracy and reliability.



### BAFFLE KIT

Solves the 1/4" tank (low fuel level) issues commonly plaguing lift pump systems.

### 3/4" DRAW STRAW

Reduces the amount of vacuum the pump generates by reducing the amount of air introduced to the fuel.



### PRE-ASSEMBLED HOSES 5/8" PUMP FEED LINE

Push-on (industry standard) J2044 quick-connects makes installation a snap.



### WEATHER PACK CONNECTORS

Simple 4 connection installation, power braided protective covering and Delphi (industry standard) Weather Pack connections for a corrosion free connection.



## MORE FEATURES :

- Unique draw-through technology
- Flow-through design eliminates shaft seal failure and leaking
- Self priming, no need to pre-fill the filter during install or filter swap
- OEM style return - no need to modify filler neck
- Complete bolt-on and plug-in installation

US Phantom Patent Nos.  
8,783,287  
9,567,954





# COMPACT EFI

Aeromotive performance in a smaller and lighter package. Capable of supporting applications up to 1000hp, the #13129 regulator can handle high-flow EFI fuel pumps and the most aggressive street machines out there. It's perfect for those looking for a cleaner, lighter solution where performance is critical or where space is a premium.

- Base pressure is adjustable from 30-70psi
- (x2) ORB-06 inlet/outlet ports and (x1) ORB-06 return port
- Dedicated, 1/8" NPT gauge port and vacuum boost port
- Fuel pressure rises on a 1:1 ratio when referencing boost

- #13136 - All Black Regulator
- #13129 - Silver/Black Regulator
- #13130 - Regulator with (x3) ORB-06 port fittings and (x1) 0-100psi gauge



E COMPATIBLE



COMPACT  
GM  
LT1

Originally developed for the GM LT1 fuel rail, these regulators are designed to keep these cars performing at their peak potential. These rail mount EFI regulators fit a variety of factory GM vehicles.

- Return adapter may be replaced with #15606 for a -06 return line

#13106  
92 - 96 Corvette  
GM Ram-Jet 350 EFI Crate Engine

#13107  
94 - 96 Impala  
94 - 97 F Body Camaro/Firebird  
GM 3.1L & 3.4L V6 engines



## HONDA COMPACT EFI

These billet adjustable regulators were specifically designed for Honda and Acura engines to provide fully adjustable base fuel pressure. They are direct bolt-on for engines with the factory fuel rail or aftermarket fuel rails designed with mounting provisions for the stock regulator.

- |                          |                          |                      |
|--------------------------|--------------------------|----------------------|
| #13115 (98-01 2.3L VTEC) | #13116 (92-97 1.6L VTEC) |                      |
| 98 - 02 Accord 4 cyl     | 86 - 89 Accord LXi/SEi   | 93 - 95 Del Sol S/Si |
| 96 - 97 Del Sol Si       | 92 - 95 Civic            | 94 - 97 Del Sol VTEC |
| 00 - 04 S2000            | 99 - 00 Civic Si         | 89 - 91 Prelude Si   |
| 98 - 99 CL 2.3L          | 94 - 01 Integra          |                      |



#13102

#13103

## FORD 4.6L | 5.0L | 5.4L

E COMPATIBLE

This is an adjustable billet fuel pressure regulator designed to handle the demands of the Ford 4.6L, 5.0L and 5.4L engines. Installs easily on the stock factory fuel rail. High flow design ideal for Stealth 340 pump.

- Adjustable from 30-70 psi
- Fuel pressure rises on a 1:1 ratio when referencing boost
- 1/8" NPT gauge port
- Stainless steel spring, custom-designed for precise fuel control
- Installation kit includes O-rings and gaskets

#13103 : 1986-1993 5.0L  
#13102 : 94-98.5 4.6L & 94-95 5.0L

# A1000

## EFI REGULATORS

### GEN II A1000

The same performance the industry has come to trust, in a new lightweight compact body. These performance EFI regulators are designed for medium to high horsepower applications. They feature Aeromotive's high-flow design, superb pressure control, and legendary durability.

- Base pressure adjustable from 40-75 psi
- Gasoline and alcohol compatible
- Fuel pressure rises on a 1:1 ratio with boost
- ORB-06 Return Port and 1/8" NPT gauge port

- ORB-06 #13138
- ORB-08 #13139
- ORB-10 #13140



Patent No. D763,409

## CLASSIC A1000

On the street and at the track, these regulators have logged more miles, more passes, and more laps than any other performance EFI regulators in the world!

- Base pressure adjustable from 40-75 psi
- Gasoline and alcohol compatible
- Fuel pressure rises on a 1:1 ratio with boost
- 1/8" NPT gauge port

- ORB-06 RED/SILVER #13109
- ORB-06 PLATINUM #13159
- ORB-10 BLACK/RED #13101
- ORB-10 ALL BLACK #13128
- ORB-10 PLATINUM #13151
- ORB-10 HARDCOAT #13114



E COMPATIBLE

# X1 REGULATORS



**LEGENDARY AEROMOTIVE PERFORMANCE**

- 1/8" NPT gauge port
- 1:1 boost reference
- Carbureted or EFI
- Supports up to 2,000hp

**Our First Ever Interchangeable Diaphragm, Spring & Seat**

Color Coded Internals for Easy Identification

All New Light Weight Compact Design

ORB-08 Inlet and Outlet Ports



	EFI	CARB	BIG EFI
<b>Configuration</b>	.188" seat 35-75 psi	.313" seat 3-20 psi	.313" seat 35-75 psi
<b>Complete Regulators</b>	#13303	#13304	#13305
<b>Conversion Kits</b> Diaphragm, Spring & Seat	#13013	#13014	#13015

Patent No. D763,409

## The Last Regulator You'll Ever Need.

Whether carbureted or EFI, naturally aspirated or forced induction, the X1 is designed to span the entire range of applications and provide dependable fuel pressure regulation. Making the change from a carburetor to EFI or EFI to carburetor? There is no longer a need to purchase a new regulator. Simply utilize one of three conversion kits (sold separately) to match the operating range required of your engine. Replace the original X1 Series regulator internals with the conversion kit of your choice (#13013, #13014, #13015) and you have a regulator with vastly different characteristics.

While versatility is one of the X1's greatest assets, it is far from the only new design feature. Utilizing larger (x3) AN-08 inlet/outlet/return ports to accommodate increased flow, Aeromotive incredibly reduced overall weight by 33% (compared to Aeromotive #13109 regulator). Even with these new design components, none of the traditional features expected of a genuine Aeromotive product have been neglected. Still integrated is the 1/8" NPT gauge port and 1:1 ratio boost reference port for easy forced induction connection. The X1 Series provides flexible performance that changes with you fuel system requirements.

# PRO-SERIES EXTREME FLOW EFI

This is the tuner's choice for high horsepower EFI applications. The Pro-Series Regulator can support up to 2,000hp. For engines requiring high volume, high pressure fuel delivery the Pro-Series EFI Regulator is a perfect fit for serious power.



## TWO PORT #13134 FOUR PORT #13110

- Includes two springs for 30-75 psi (installed) and 75-120 psi (provided)
- Auxiliary ports available for nitrous applications, pressure gauges etc.
- References Vacuum/Boost on a 1:1 ratio. Includes two boost line adapters: one barbed for rubber hose, the other for AN-04 braided line (this prevents blow-off in high boost applications)
- Dedicated 1/8" NPT port
- Includes Aeromotive's radiused, tapered flare fittings: (x3) ORB-08 and (x1) ORB-10 inlet ports, two with AN-08 flare adapters (x1) ORB-10 return port with AN-10 flare adapter port plugs included



# BELT DRIVE EFI REGULATORS

**TWO PORT**  
#13132 (x2) AN-10 ports  
#13137 (x2) AN-12 ports

**FOUR PORT #13133**  
(x1) AN-10 and (x4) AN-08 ports  
and (x1) AN-10 return port

- Designed for use with Belt or Hex Drive Fuel Pumps
- 0.500" high flow valve/seat, able to handle 7-26 GPM
- Dual springs expand operating pressure range while maintaining a low profile and reduce weight
- Standard spring (installed) supports 30-75 psi base
- High Pressure (included) supports 75-120 psi base
- Supports 1:1 vacuum and boost reference



## SINGLE SPRING #13113

Engineered for our Belt-Drive and Hex-Drive Fuel Pumps, the Belt Drive EFI Regulator is suitable for engines making up to 4,000hp on gasoline and is compatible with gasoline and methanol.

- **Base pressure adjustable from 40-100 psi.**



## UNIVERSAL #13301

This universal regulator serves two purposes. It can be used for EFI or carbureted applications whether it be street or strip applications. Base pressure adjustable from 3 to 20 psi with standard spring, (installed) or from 20 to 60 psi with high pressure spring (included). It offers the full flow and rock steady fuel pressure that only a dynamic, Aeromotive bypass regulator provides.

- Capable of regulating any fuel pump between 100 and 250GPH
- Fuel pressure rises on a 1:1 ratio when referencing boost
- All ports are 3/8" NPT, with one inlet and three outlets on the main body and one return port on the bottom
- Bypass design provides the ultimate, dynamic fuel pressure control

## EFI TO CARB

CONVERSION REGULATOR

### Part Number 13220

Allows any car or truck, originally equipped with a return-style EFI system, to affordably convert to a standard carburetor.

- Bypass pressure is adjustable from 8-16 psi, regulated pressure to the carburetor is adjustable from 5-9 psi
- 3/8" NPT inlet, outlet and return ports
- 1/8" NPT gauge port



## ULTRA LOW-PRESSURE #13222

### CARBURETED DEADHEAD

This is one of the newest regulators in Aeromotive's line up. It's engineered with a high-flow, soft seat valve capable of supporting up to 750hp while providing a rock solid low pressure control without any creep. Simply the finest low-pressure regulator ever offered to the automotive after market.

- Adjustable from 2-5 psi
- Ideal for small sidedraft-style carburetors
- (x1) ORB-6 inlet port and (x2) ORB-6 outlet
- 1/8" NPT gauge port
- Clear anodized finish for a subtle look

# SS SERIES

## CARBURETED DEADHEAD

Specifically designed for carbureted street or racing engines up to 750hp. These adjustable regulators offer higher flow, quicker response, and less pressure creep than competing two-port designs. Ideal for dedicated nitrous applications.

- Adjustable from 5-12 psi
- Regulators re-seat after the carburetor needle shuts down, preventing pressure creep



#13205

**ORB-06 BLACK/RED #13201**  
 #15203 Includes (x3) ORB-08 Port Fittings  
 #15108 Includes (x3) ORB-06 Port Fittings

**ORB-06 PLATINUM #13251**

**ORB-06 HARDCOAT #13211**

**3/8 NPT RED/SILVER #13205**  
 #15205 Includes (x3) 3/8" NPT / AN-08 Fittings  
 #15204 Includes (x3) 3/8" NPT / AN-06 Fittings

**3/8 NPT PLATINUM #13255**

**3/8 NPT HARDCOAT #13215**



#13201

# STACKABLE #13217

GAS ONLY

Aeromotive's Patented Stackable Carbureted Fuel Pressure Regulators are ideal for carbureted nitrous engines. These regulators allow you to "stack" them together to control multiple pressures with a single fuel pump. The new "Stackable Regulator" is a clean, lightweight solution ideal for nitrous engine combinations where individual pressures are desired.

- Adjustable from 5-12 psi.
- ORB-10 inlet and outlet flow-through ports
- (x2) ORB-06 outlet ports
- Includes (x2) O-rings, (x2) 12-point cap screws
- Serviceable in the field without having to remove from the vehicle



Pair with #11217 Regulator and inline gauge adapters for precise control.

Patent No. D628,274



\*Fittings not included

## DOUBLE ADJUSTABLE CARBURETED BYPASS

Our double adjustable regulators' revolutionary design provides two independent pressure adjustments; one adjustment for idle and one for wide-open throttle. They're engineered for use with mechanical, belt, or hex drive pumps tied to engine RPM. This regulator creates the smoothest and most repeatable fuel curve from idle to wide-open throttle of any bypass system.

- Pressure range : down to 3 psi @ idle and up to 18 psi @ WOT
- ORB-10 return port
- Can be configured for single or dual-carbureted engines, and provides superior pressure control and flow when installed before the carburetor or after a fuel log
- #13214 available with fuel log #14201 or #14202, fittings, and gauge as #17249 or #17251.

#13209 : (x1) ORB-08 inlet and (x3) ORB-08 outlet ports.  
#13214 : (x1) ORB-10 and (x1) ORB-10 return.



E COMPATIBLE

E COMPATIBLE

# A1000 CARBURETED BYPASS

The A1000 Carbureted Bypass Regulators were designed for use with our A1000 Fuel Pump or similar style EFI pumps in a carbureted application. These regulators are perfect for naturally aspirated or "blow-through" supercharged engines. They're also ideal for Phantom 200, 340, and Flex Universal Fuel Systems.

- Base fuel pressure adjustable from 3-15 psi
- (x1) ORB-10 inlet port and (x1) ORB-08 return port
- Fuel pressure rises on a 1:1 ratio when referencing boost
- Bypass design provides the ultimate, dynamic fuel delivery system
- Ideal for converting from fuel injection to carburetion with the appropriate larger return line

#13224 : (x4) ORB-06 outlet ports and 1/8" NPT gauge port

#13204 : (x2) ORB-06 outlet ports and 1/8" NPT gauge port

**HARD COAT #13207** **PLATINUM #13254**



#13204

#13224

E COMPATIBLE

# A2000 CARBURETED BYPASS

Dynamic flow and rock steady pressure make this regulator perfect for naturally aspirated or carbureted "blow-through" applications. The A2000 Bypass Regulator provides unmatched boost reference and high-flow capacity. Compatible with any high volume electric or mechanical fuel pump.

**TWO PORT #13212**  
**FOUR PORT #13202**

- Adjustable from 2-20 psi base pressure
- Bypass design provides the ultimate, dynamic fuel delivery system. (Requires AN-10 return)
- Fuel pressure rises on a 1:1 ratio with boost
- ORB-10 inlet and return ports



#13212

#13202



## PRO STOCK CARBURETED DEADHEAD REGULATORS

Track-tested by record setting, professional racers, the Aeromotive Pro Stock Regulators were designed to be used with the Aeromotive A2000 (#11202) and A3000 (#11215) Fuel Pumps in either single or dual carburetor applications. Utilizing a stainless steel valve, aluminum bronze seat, and an innovative opposed-spring design, the Pro Stock Regulators are engineered to be the quickest responding, most reliable, highest flowing regulators in the industry.

- Adjustable from 4-8 psi
- ORB-12 inlet port (Includes ORB-12 to AN-10 inlet fitting)
- 1/8" NPT gauge port
- Includes mounting bracket

**FOUR PORT  
ORB-06 | #13208**

**TWO PORT  
ORB-08 | #13210**

**E COMPATIBLE**



## A4 CARB PART NUMBER #13203

- Soft-seat design eliminates pressure creep, making it perfect for throttle-stop cars
- Adjustable from 5-15 psi
- Gasoline and alcohol compatible
- Standard deadhead design, no return line required
- (x4) ORB-06 outlet ports and 1/8" NPT gauge port
- (x2) ORB-10 inlet ports for plumbing flexibility

**E COMPATIBLE**

**WARNING** : This product can expose you to chemicals, including chromium, which is known to the State of California to cause cancer or birth defects or other reproductive harm.

## VACUUM PUMP REGULATOR #33101

Aeromotive's Vacuum Pump Regulator allows you to control and adjust crankcase vacuum easily and effectively without the use of shims. Simply loosen the lock nut and turn to adjust.

- Works with most popular aftermarket vacuum pumps
- Equipped with (2) ORB-12 Inlet and Outlet Ports
- Features a 1/8" gauge port
- Made from CNC-Machined Billet Aluminum

Patent No. D622,288



## REPLACEMENT FUEL CELLS

**#18006 - 6g Stealth Fuel Cell Only**  
Dimensions: 12"w x 12"l x 10"h

**#18007 - 15g Stealth Fuel Cell Only**  
Dimensions: 18"w x 20"l x 10"h

**#18008 - 20g Stealth Fuel Cell Only**  
Dimensions: 20"w x 24"l x 10"h

**6 GAL Fuel Cell Bracket - #18701**  
(For 2010+ Mustangs)



## DIAPHRAGM SERVICE KITS

Complete rebuild kits for your Aeromotive fuel pressure regulator.  
Note: If required, some kits will include spring as well.

Kit #	Applicable Regulators
#13001	13101, 13109, 13151, 13159, 13114
#13002	13102, 13103, 13152, 13153
#13003	13105, 13155, 13106, 13107, 13115, 13116, 13129, 13136
#13004	13110, 13224, 13134, 13304, 13305
#13005	13201, 13205, 13211, 13215, 13217, 13251, 13255
#13006	13202, 13113, 13209, 13214, 13212, 13132, 13133
#13007	13203
#13008	13204, 13207, 13254
#13009	13301, 13351
#13010	13208, 13210
#13701	13301, 13351 (Spring only)
#13022	13222



**WARNING** : This product can expose you to chemicals, including chromium, which is known to the State of California to cause cancer or birth defects or other reproductive harm.



# THE *In-line* Fuel Filter GUIDE

## \*REPLACEMENT ELEMENTS

All replacement elements include (x1) filter housing o-ring



# FILTERS

Finally, a place where bigger really is better. What defines an efficient filter? As little pressure drop as possible. How do you achieve a low pressure drop? Surface area. How do you get a lot of area into a compact in-line filter? Pleats. More pleats mean more surface area and in turn, better flowing filters. Aeromotive in-line filters boast the most surface area absolutely possible for the highest flowing filters.

Our fuel filters aren't just better on the inside, they are arguably the most appealing filter in the industry on the outside. They are machined out of aircraft-grade billet aluminum alloy and precision coated with your option of bright dip red or black anodizing, hardcoat, and even a nickel plated finish in our Platinum Series.

Variety, quality, unmatched performance, and finish leave all other filters in the dust. Don't trust your investment with any other filter.

**WARNING** : This product can expose you to chemicals, including chromium, which is known to the State of California to cause cancer or birth defects or other reproductive harm.

## FEMALE END

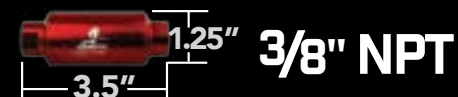

## MALE END AN-06



## SHUT - OFF ORB-10



## ORB-12

## CANISTER

- 3/8" NPT ports
- 6.125" x 3.75"



## 100 MICRON STAINLESS MESH ALL FUELS

- 12316 - RED
- 12366 - PLATINUM
- 12616 - ELEMENT

- 12304 - RED
- 12324 - BLACK
- 12354 - PLATINUM
- 12307 - HARD COAT
- 12604 - ELEMENT
- 12614 - CRIMP ELEMENT

- 12302 - PRO SERIES
- 12352 - PLATINUM
- 12309 - HARD COAT
- 12602 - ELEMENT

- 12349 - BLACK

- 12379 - BLACK

- 12389 - BLACK
- 12604 - ELEMENT

- 12331 - BLACK
- 12604 - ELEMENT

- 12332 - BLACK
- 12602 - ELEMENT

- 12318 - RED & POLISH
- 12319 - RED & BLACK
- 12618 - ELEMENT

## 40 MICRON STAINLESS MESH ALL FUELS

- 12303 - RED
- 12353 - PLATINUM
- 12603 - ELEMENT

- 12335 - RED
- 12330 - BLACK
- 12635 - ELEMENT

- 12342 - PRO SERIES
- 12343 - HARD COAT
- 12642 - ELEMENT

- 12348 - BLACK

- 12378 - BLACK

- 12388 - BLACK
- 12635 - ELEMENT

7.375" long x 2" diameter

8.875" long x 2.5" diameter

## 10 MICRON CELLULOSE GAS & DIESEL

- 12301 - RED
- 12321 - BLACK
- 12351 - PLATINUM
- 12306 - HARD COAT
- 12601 - ELEMENT

- 12310 - PRO SERIES
- 12360 - PLATINUM
- 12311 - HARD COAT
- 12610 - ELEMENT

- 12347 - BLACK

- 12377 - BLACK

- 12387 - BLACK
- 12601 - ELEMENT

## 10 MICRON MICRO GLASS E85 / ALCOHOL

- 12340 - RED
- 12350 - BLACK
- 12346 - HARD COAT
- 12650 - ELEMENT

- 12339 - PRO SERIES
- 12341 - HARD COAT
- 12639 - ELEMENT

- 12345 - BLACK

- 12375 - BLACK

- 12385 - BLACK
- 12650 - ELEMENT

### Features

- Proprietary stainless steel shut-off valve design
- 100 micron stainless steel filter element
- Please see the following page for more information

- 12308 - RED & POLISH
- 12317 - RED & BLACK
- 12358 - PLATINUM
- 12608 - ELEMENT

**WARNING** : This product can expose you to chemicals, including chromium, which is known to the State of California to cause cancer or birth defects or other reproductive harm.



## IN-TANK PRE-FILTER

The new Stealth Pre-Filter is installed inside the tank. It replaces the fuel cell outlet bulkhead with a unique bulkhead fitting that provides support for the filter on the inside while providing the high-flow connection needed to feed the pump on the outside.

- #12612 AN-10 male flare - 100-micron stainless steel element
- #12613 AN-12 male flare - 100-micron stainless steel element

- #12606 Stealth 100m Crimped Element  
- screws onto existing ORB-10 cell bulkhead, or add #15646

## DUAL OUTLET

Dual Outlet Fuel Filters with secondary outlet port. Available in ORB-10 and ORB-12 port sizes. They eliminate the need for additional fittings and y-blocks, allowing you to feed separate systems from one filter.

- Features 10-micron fabric filter elements
- Port plug for secondary port included

- #12333 : ORB-10 ports with ORB-06 secondary port
- #12334 : ORB-12 ports with ORB-08 secondary port



## SHUT-OFF FILTER

Ever take a fuel bath when changing your filter? We have a solution! Cleaning and replacing your filter elements used to mean draining your gas tank. The Aeromotive Shutoff Valve Fuel Filters allow you to shutoff fuel flow and replace your filter elements with little or no fuel loss. Both feature 100-micron stainless steel elements and are recommended for use between the fuel cell or sumped tank and the fuel pump inlet.

- Proprietary stainless steel shutoff valve design
- 100-micron stainless steel filter element
- Type II bright dip black anodized assembly and red anodized billet aluminum shutoff valve handle
- Perfect for pre-pump filtration

- #12331 - ORB-10 ports (Dimensions: 7.375" long x 2" diameter)
- #12332 - ORB-12 ports (Dimensions: 8.875" long x 2.5" diameter)



## MOUNTING BRACKETS

2" ORB-10 Billet Clamp #12305  
PLATINUM #12355

2.5" ORB-12 Billet Clamp #11703  
PLATINUM #11753

2" Spring Clip #12701

2.5" T-Bolt Clamp #12702

## FUEL RAILS



Billet fuel rails that actually fit. The advantage of a company that understands engineering, design and manufacturing, is peace of mind. When you buy a set of rails from Aeromotive, you can be assured they will fit and deliver as promised, not leak and disappoint.

Our Rail Systems take fuel rails to another level. Adding innovative couplers allow you to install our rails on many popular domestic and import performance vehicles, while utilizing our specifically designed billet fuel pressure regulators for added tuning control.

Systems : Includes Rails, Regulator, Fuel Line, Fittings and Hose Ends  
Rail Kit : Includes Fuel Rails only



## FORD

### 4.6L MUSTANG

- Rail Kit #14103 96 - 04 SOHC GT Kit
- Rail Kit #14104 96 - 98 1/2 DOHC Cobra Kit
- Rail Kit #14111 98.5 - 04 DOHC Cobra Kit
- Rail Kit #14116 05 - 10 3-valve GT Kit
- System #14119 98.5 - 04 SOHC GT, Returnless
- System #14125 96 - 98.5 SOHC GT, Return-Style
- System #14120 96 - 98.5 DOHC Cobra, Return-Style
- System #14122 98.5 - 04 DOHC Cobra, Returnless
- System #14124 05 - 10 3-valve GT, Returnless
- System #17114 Fuel Pressure Sensor Relocation Kit (also available separately #15110)

### 5.0L MUSTANG

- Rail Kit #14101 86 - 95 GT & Cobra Kit
- System #14102 GT & Cobra, Return-Style

### 5.4L TRUCK+SUV

- Rail Kit #14110 99 - 04 Lightning/Harley Kit
- Rail Kit #14117 97 - 05 2-Valve Truck & SUV Kit
- System #14127 99 - 04 Lightning/Harley, Return-Style
- System #14118 97 - 05 2-Valve Truck & SUV, Return-Style

### 5.4L GT500

- Rail Kit #14144 07 - 09 GT500 Kit
- System #14145 07 - 09 GT500, Returnless

### 5.0L COYOTE

- Rail Kit #14130 11 - 16 5.0L Coyote Mustang GT

### COBRA JET

- Rail Kit #14141 10 - 12 5.4L Cobra Jet Mustang  
\*Black Anodized

# GM

## FUEL RAIL KITS

- #14106 97 - 04 LS1, 01 - 05 LS6 Kit
- #14113 05 - 06 Cadillac Northstar Kit
- #14114 05 - 06 LS2 Kit
- #14115 GM LS3 / L76 Kit
- #14131 96 - 07 GM Supercharged 3.8L Kit
- #14142 LS7 Corvette Kit
- #14147 Edelbrock® LS1 Intake (29085) Kit

## FUEL RAIL SYSTEMS

- #14139 98 - 02 LS1 F-Body, Returnless
- #14139 04 LS1 GTO, Returnless
- #14128 99 - 04 LS1 Corvette, Returnless
- #14129 99 - 03 1/2 LS1 Corvette, Return-Style

Fuel Rail Kit : rails only    Fuel Rail System: includes rails, regulator, fuel line, fittings and hose ends



# SUBARU

## FUEL RAIL KITS

- #14134 **Top Feed** 2002-2014 WRX & 2007-2015 STI
- #14136 **Side Feed** 2002-2014 WRX & 2007-2015 STI

## FUEL RAIL SYSTEMS

Regulator, port fittings, fuel lines and hose-ends, gauge, OEM supply and return line adapter fittings

- #14135 **Top Feed** 2002-2014 WRX & 2007-2015 STI
- #14137 **Side Feed** 2002-2014 WRX & 2007-2015 STI



# MOPAR

## FUEL RAIL KITS

- #14146 - Chrysler 5.7L & 6.1L HEMI
- #14158 - Mopar Gen 4 - 8.4L (V10) Viper Kit



## SPECIALTY FUEL RAILS

- #14148 SBC Victor "E" (29785) Kit
- #14149 SBF Super Victor EFI Intake Kit (29285 & 29245)
- #14105 Mitsubishi 4G63
- #14132 Mitsubishi EVO 2003-2007
- #14163 Volkswagen / Audi 1.8L Turbo
- #14112 Acura Integra 1994-2001

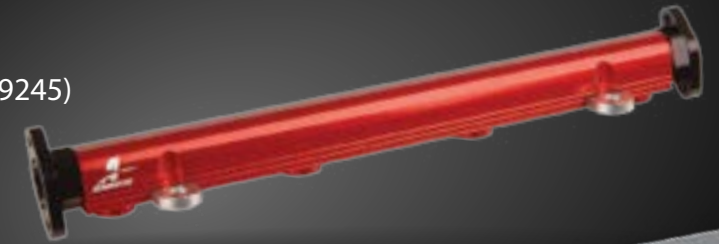

## MAKE YOUR OWN

- #14107 Unmachined Raw Extrusion (17.75" length, one each)

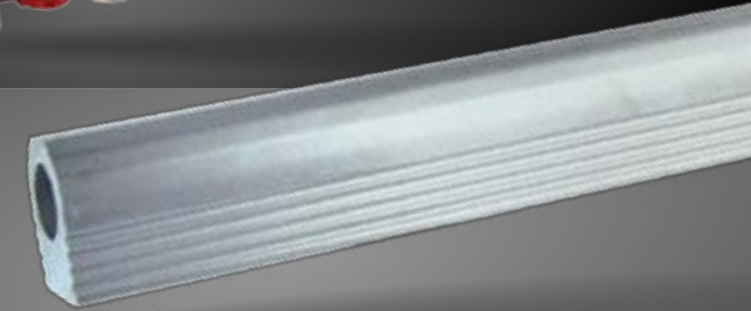

## DUAL ACTION ADJUSTABLE

# FUEL LOG



- Carburetor inlets swivel + or - 20° in all directions
- Telescoping center line is 7.700" to 13.450"
- ORB-10 inlet and outlet ports
- (x 2) 1/8" NPT ports for gauges or pressure transducers
- 1.056 / .806" ID bore
- Type II bright dip black anodized finish



### #14201 4150 / 4500 Holley-style float bowls

- #17248 - Includes A2000 Bypass 2-port Regulator #13212
- #17249 - Includes Double Adjustable Bypass Regulator #13214

### #14202 Demon style float bowls (9/16 x 24 Thread)

- #17250 - Includes A2000 Bypass 2-port Regulator #13212
- #17251 - Includes Double Adjustable Bypass Regulator #13214

### #14203 Holley Ultra HP-Style float bowls (3/4 x 16 Thread)

### Conversion Kits/Inlet Replacements

- #14001 - Seal Rebuild Kit for Fuel Logs
- #14002 - Inlets/Standoffs for Demon Style Inlet
- #14003 - Inlets/Standoffs for 4150/4500 Holley Style Inlet
- #14004 - Inlets/Standoffs for 3/4 x 16 Thread (Ultra HP)



## ORB-AN FLARE WITH GAUGE ADAPTER



ORB-06	AN-06 MALE FLARE	1/8" NPT Port	#15694
ORB-08	AN-08 MALE FLARE	1/8" NPT Port	#15695
ORB-10	AN-10 MALE FLARE	1/8" NPT Port	#15696

# FUEL PRESSURE GAUGE

## Featuring Built-In Equalizer Pin

While there are many advantages to the liquid filled design, there has always been an inherent issue: when underhood temperature increases, so does the oil inside the gauge. As the oil heats up and expands this causes the pressure inside the gauge to read differently. These gauges offer a pressure relief valve that equalizes pressure between the atmosphere and the gauge when activated.

0-15 PSI #15632  
0-100 PSI #15633

- Includes integral pressure relief valve, for accurate readings during hot conditions
- Standard 1/8" NPT
- 1.5" Diameter
- Available for both EFI and carb applications
- Liquid-filled for increased durability

**Did You Know?**  
Most liquid-filled gauges can give false readings due to the pressure created by heat under the hood.



# FUEL PUMP SPEED CONTROLLER

## #16306

For any pump, on any type of vehicle, the Aeromotive Fuel Pump Speed Controller (FPSC) minimizes fuel heating and vapor-lock problems by matching the duty cycle of the fuel pump to engine RPM. At low demand, the FPSC slows the fuel pump down, reducing the chance of suction side cavitation and vapor lock. When demand increases, the FPSC returns the fuel pump to 100% duty cycle for maximum flow. It's like an automatic transmission for your fuel pump.



- Adjustable idle and full-speed RPM threshold. Uses pulse modulation to smoothly ramp speed up and down
- LED indicators confirm correct ignition signal hookup, verifies activation of the manual override circuit, and indicates when the circuit is providing full voltage to the pump
- A solid-state transistor circuit, rated up to 40 amps, replaces the relays recommended in most fuel pump electrical circuits
- Billet 6061-T651 aircraft aluminum housing, protected with a beautiful bright dip black anodized finish
- Complete installation kit includes: wire, override toggle switch, installation hardware, and instructions

**Avoid any device that reduces voltage to your fuel pump. Low voltage will destroy a 12V DC motor. The Aeromotive FPSC DOES NOT reduce voltage! The FPSC emits a pulse modulation signal that is harmless to the pump's motor.**

## FUEL PUMP WIRING KIT

### #16301- 30 AMP



## PREMIUM FUEL PUMP WIRING KIT

### #16307 30 AMP



## DIRECT PORT



ORB-06	AN-06 MALE FLARE	90°	#15689
ORB-10	AN-08 MALE FLARE	90°	#15690
ORB-10	AN-10 MALE FLARE	90°	#15691
ORB-08	AN-08 HOSE END TIGHT 90°		#15665

## ORB SWIVEL

ORB-08	ORB-10	#15638
ORB-10	ORB-10	#15640
ORB-12	ORB-12	#15680
ORB-08	ORB-06	#15681
ORB-10	ORB-12	#15682
ORB-10	ORB-10	#15639 w/ ORB-06 Port



## STRAIGHT AN

AN-06	Straight	#15650
AN-08	Straight	#15653
AN-10	Straight	#15656
AN-12	Straight	#15659

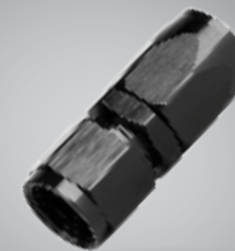

## 90° SWIVEL

AN-06	90°	#15652
AN-08	90°	#15655
AN-10	90°	#15658
AN-12	90°	#15661



## FORD FUEL TANK BILLET RETURN ADAPTER #18603 - ORB-08 RETURN PORT



## ORB Y-BLOCK

#15620 - (x1) ORB-10 and (x2) ORB-08



## 45° SWIVEL

AN-06	45°	#15651
AN-08	45°	#15654
AN-10	45°	#15657
AN-12	45°	#15660

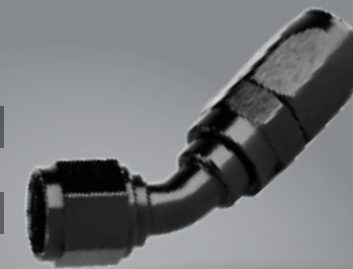

## 180° SWIVEL

AN-08	180°	#15663
-------	------	--------



## AN Y-BLOCKS



-12 to (2)-12	#15679
-12 to (2)-10	#15678
-12 to (2)-8	#15677
-10 to (2)-10	#15676
-10 to (2)-8	#15675
-8 to (2)-8	#15674
-8 to (2)-6	#15673
-6 to (2)-6	#15672
-6 to (2)-4	#15671

## ORB TO AN FLARE



Long Internal Radii Reduces Cavitation



ORB

AN

ORB-08	AN-06	#15605
ORB-06	AN-06	#15606
ORB-08	AN-08	#15607
ORB-10	AN-10	#15608
ORB-10	AN-06	#15609
ORB-10	AN-08	#15610
ORB-12	AN-12	#15612
ORB-12	AN-10	#15613
ORB-04	AN-04	#15629
ORB-08	AN-10	#15641
ORB-10	AN-12	#15642
ORB-06	AN-08	#15649

## BULKHEAD FITTINGS

AN-06	Fuel Cell Bulkhead	#15644
AN-08	Fuel Cell Bulkhead	#15645
AN-10	Fuel Cell Bulkhead	#15646
AN-12	Fuel Cell Bulkhead	#15647
AN-06	AN-06 Male Flare	#15684
AN-08	AN-08 Male Flare	#15685
AN-10	AN-10 Male Flare	#15686
AN-12	AN-12 Male Flare	#15687

Fuel Cell



Male Flare



AN-06	Replacement Nylon Washer (2 pk)	#15044
AN-08	Replacement Nylon Washer (2 pk)	#15045
AN-10	Replacement Nylon Washer (2 pk)	#15046
AN-12	Replacement Nylon Washer (2 pk)	#15047

## ORB PORT PLUGS

ORB-10	HEX	#15617
ORB-08	Slim Line	#15618
ORB-06	HEX	#15626
ORB-06	HEX - 1/8" Gauge Port	#15697
ORB-08	HEX - 1/8" Gauge Port	#15637



## Banjo Fitting ORB-08 / AN-06 Male Flare #15636



## AN FLARE UNION

AN-06	AN-06	#15602
AN-08	AN-08	#15603
AN-10	AN-10	#15604
AN-12	AN-12	#15611
AN-08	AN-06	#15614



## NPT/AN FLARE

3/8" NPT	AN-06	#15615
3/8" NPT	AN-08	#15616
1/16" NPT	AN-04	#15619
1/16" NPT	5/32"	#15630



## FEMALE COUPLER

AN-08	AN-08	#15692
-------	-------	--------



## HOSE BARB

ORB-06	7mm	#15627
ORB-04	5/16"	#15628
AN-06	5/16"	#15635



# ONE WAY CHECK VALVE

**ORB-10 #15107 ORB-06 #15106**

Our high flow one-way check valves are designed to prevent back-flow with minimal pressure drop. Ideal to prevent drain back after the fuel pump is turned off, or when dual pumps are used and both pumps may not run simultaneously.

- CNC-machined billet aluminum and Type II bright dip black anodized finish
- AN O-ring male inlet/female outlet connections allow easy installation into fuel pump or filter outlet port without adding additional lines, hose ends or fittings
- **Suitable for use with gasoline fuels only**



# REPLACEMENT ORB RINGS

ORB-06	Fuel Resistant Nitrile - 10 Pack	#15621
ORB-08	Fuel Resistant Nitrile - 10 Pack	#15622
ORB-10	Fuel Resistant Nitrile - 10 Pack	#15623
ORB-12	Fuel Resistant Nitrile - 10 Pack	#15624



# REPLACEMENT FILTER O-RINGS

2" Diameter Filter Housings	#12001
2.5" Diameter Filter Housings	#12002
1.25" Diameter Filter Housings	#12003
Canister Style Filter Housings	#12008
A3000 Pre-Filter	#12018



## Ford Male Spring Lock Adapter

Ford 1/2" Male Spring Lock/AN-06 Feed Line Adapter : **#15124**

Ford 3/8" Male Spring Lock/AN-06 Feed Line Adapter : **#15123**

Ford 1/2" Male Spring Lock/AN-08 Feed Line Adapter : **#15125**



1/2" Quick Connect/ORB-10 **#15128**  
 3/8" Quick Connect/ORB-08 **#15118**  
 5/16" Quick Connect/ORB-06 **#15117**

## 4 Port Fuel Distribution Log

#14601 - (x2) ORB-08 and (x2) ORB-06



## 10 Port Fuel Distribution Log

#14602 - (x2) ORB-10 and (x8) ORB-06



## REPLACEMENT STEALTH FILTER SOCKS

Phantom 200 & 340, includes gasket	#12688
Phantom Dual #18309 - includes gasket	#12609
Phantom Flex #18310 - includes gasket	#12611
340 Stealth Pump - #11540	#12640
340 Stealth Pump - #11541 and #11542	#12641
340 Stealth Pump - #11569	#12669

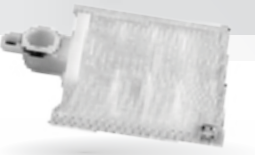

AN-08 Inlet Male Flare Adapter for Inline EFI Pump (#11109) : **#15114**



3/8" Quick Connect with AN-08 fuel access port and 1/8" NPT gauge port : **#15121**



5/16" Quick Connect with AN-06 Fuel Access port and 1/8" NPT gauge port : **#15120**



Demon Carb AN-06 to 9/16" x 24 Thread Float Bowl Fitting : **#15207**



Demon Carb AN-08 to 9/16" x 24 Thread Float Bowl Fitting : **#15208**



Holley AN-06 to 7/8" x 20 Thread Float Bowl Fitting : **#15201**



1/16" NPT to AN-04 Vacuum Boost fitting for port on regulators : **#15619**



1/16" NPT to 5/32" Hose Barb for vacuum/boost port on regulators : **#15630**



1/16" NPT Breather Vent for Vacuum/Boost port on Regulators : **#15662**



3/8" Female Spring-Lock/AN-06 Male (Ford Return Line) : **#15101**



3/8" Male Quick Connect/AN-10 Male (GM LT-1 filter inlet) : **#15104**



5/16" Male Quick Connect/AN-06 Male (Ford filter inlet / outlet) : **#15103**



Ford 4.6L Sensor Adapter Log (2) ORB-08 Ports  
**#15112** - 1999-2004 Adapter  
**#15115** - 2005-2006 Adapter



5/8" Female to AN-10 Male (GM LT-1 filter outlet) **#15105**



Fuel Pump Vibration Dampener Mounting Kit **#11601**



1/2" Female Spring-Lock/(2) AN-08 Male "T" (86-06 Ford Supply Line) **#15102**



3/8" Male Quick Connect/(2) ORB-08 Male Flare "T" (GM pressure line) **#15116**



2x Male AN-08 x ORB-06 Port Tee with 1/8" NPT gauge port **#15119**

STAINLESS STEEL RUBBER BRAIDED  
**FUEL LINE**

SIZE	LENGTH	PART #
AN-06	4'	#15701
AN-06	8'	#15702
AN-06	12'	#15703
AN-08	4'	#15704
AN-08	8'	#15705
AN-08	12'	#15706
AN-08	16'	#15711
AN-10	4'	#15707
AN-10	8'	#15708
AN-10	12'	#15709
AN-10	20'	#15710



## FUEL SAMPLE VALVE #15631

Aeromotive's Billet Fuel Sample Valve is designed to simplify installation and make fuel checks a snap! Packed with common sense features, it's simply the best sample valve on the market.

- Installs into any 1/8" NPT gauge port
- Provides a duplicate 1/8" NPT port on the valve for installation of fuel pressure gauge or pressure transducer
- Sample port is equipped with a stainless steel barb fitting for extension hose and rotates 360° for ease of installation and sampling
- The "dual action", spring-loaded safety valve keeps the valve sealed when unlocked and rotates into a locked position for racing



#17119 - 3/8" Quick Connect Sample Valve Kit,  
Fits most Ford Modular and GM LS Series Engines

## BILLET FUEL CELL CAP

- 12 BOLT #18707 For Aeromotive Fuel Cells
- WELD-ON #18708 For Custom Fuel Cells - 3.5in



# MARINE



Coast Guard Certified



Hard Coat Black Anodize



Same Legendary Performance



## Fuel Pumps

A1000	#11108
ELIMINATOR	#11110
SS SERIES	#11211
HO SERIES	#11212

## Fuel Filters

ORB-10 : 100m stainless	#12307
ORB-12 : 100m stainless	#12309
ORB-12 : 40m stainless	#12343
ORB-10 : 10m cellulose	#12306
ORB-12 : 10m cellulose	#12311
ORB-12 : 10m microglass	#12341



## Regulators

A1000 - Carb Bypass	#13207
Same as #13204	
A1000 - EFI Bypass	#13114
Same as #13101 - ORB-10 ports	
SS Series	#13211
Same as #13201 - ORB-06 Ports	
SS Series	#13215
Same as #13205 - 3/8" NPT Ports	



# POWER PLANNER

## GUIDE TO SUCCESSFUL FUEL SYSTEMS

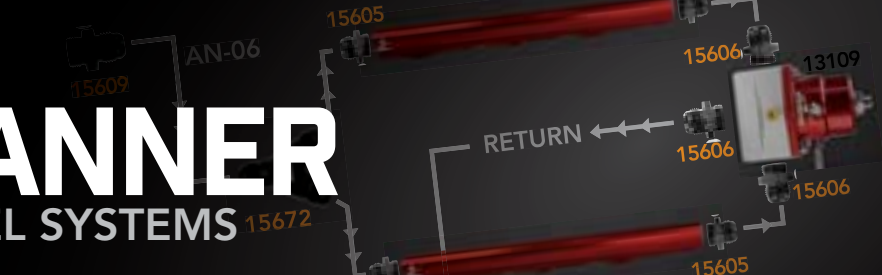

### QUICK KEY

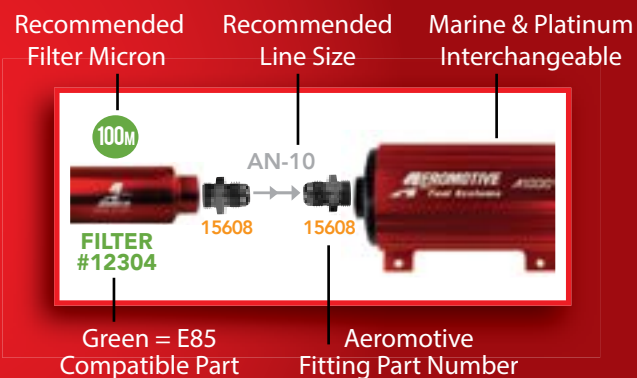

## 340 STEALTH DIAGRAMS

Diagrams Labeled "340 Stealth" are applicable for ALL 340 Stealth Products

Phantom Series 200 & 340 : see page 10  
 Gen II Stealth Tanks 200 & 340 : see page 14  
 340 Stealth Fuel Cells : see page 08

Stealth 340 Pumps : see page 07  
 (Drop in, upgrade pump. Fittings in top hat won't be applicable)

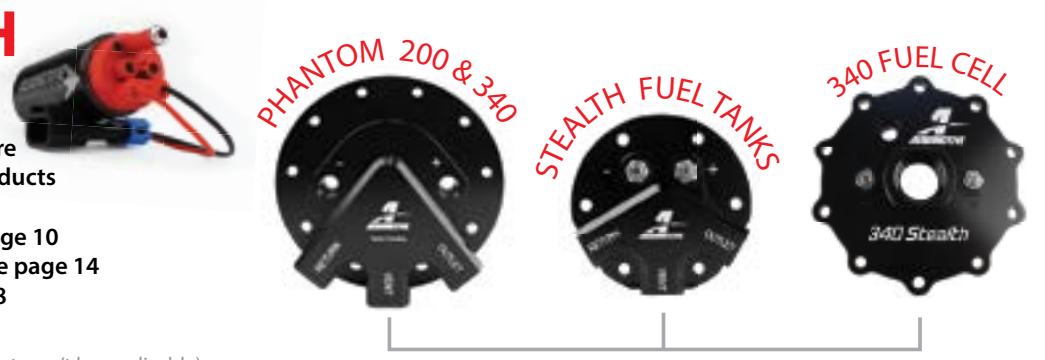

Refer To Filter Guide on page 40 for all available options and finishes



**KEY** 100M = 100 MICRON ELEMENT    10M = 10 MICRON ELEMENT    10M = E85 COMPATIBLE ELEMENT

Remember these...



Wiring Kit #16307



Pressure Gauge  
 0-15 psi #15632  
 0-100 psi #15633



Fuel Pump Speed Controller #16306



Filter Brackets  
 page 42



Fuel Line & Hose Ends  
 page 49

**WARNING** : This product can expose you to chemicals, including chromium, which is known to the State of California to cause cancer or birth defects or other reproductive harm.

## A750 FUEL INJECTED - DUAL FUEL RAIL

*flywheel	Naturally Aspirated	Forced Induction
Fuel Injected	800hp	600hp

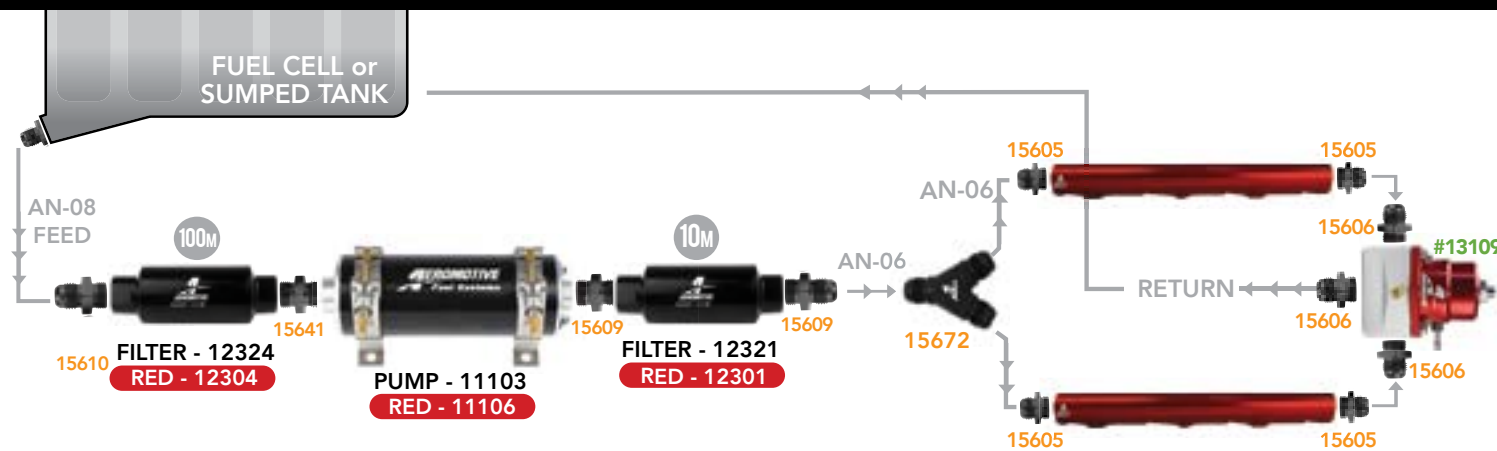

\* Pre Pump : Separate the pump from filter with a #15610 fitting, #15607 fitting, and -08 line.  
 \*\* Post Pump : Separate the pump from filter with a #15606 fitting, #15609 fitting, and -08 line.

## A750 FUEL INJECTED - SINGLE FUEL RAIL

*flywheel	Naturally Aspirated	Forced Induction
Fuel Injected	800hp	600hp

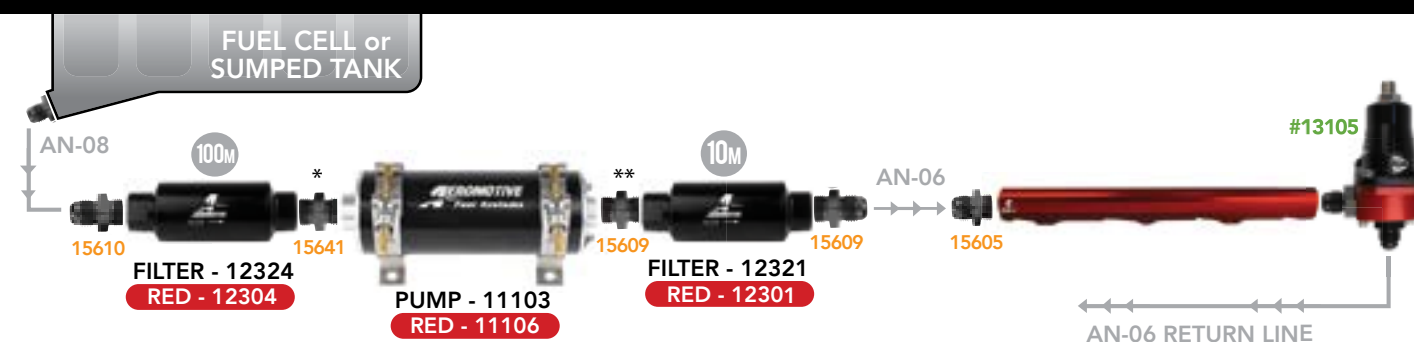

\* Pre Pump : Separate the pump from filter with a #15610 fitting, #15607 fitting, and -08 line.  
 \*\* Post Pump : Separate the pump from filter with a #15606 fitting, #15609 fitting, and -08 line.

## A750 CARBURETED - DUAL FEED - SINGLE CARB

*flywheel	Naturally Aspirated	Forced Induction
Carbureted	1,000hp	800hp

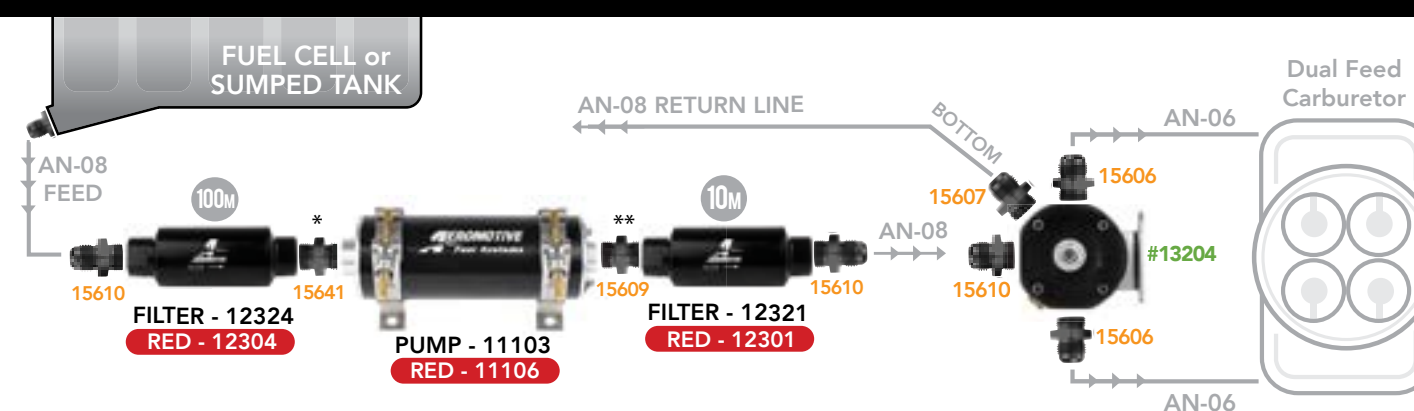

\* Pre Pump : Separate the pump from filter with a #15610 fitting, #15607 fitting, and -08 line.  
 \*\* Post Pump : Separate the pump from filter with a #15606 fitting, #15609 fitting, and -08 line.

**WARNING** : This product can expose you to chemicals, including chromium, which is known to the State of California to cause cancer or birth defects or other reproductive harm.

# A1000

FUEL INJECTED - DUAL FUEL RAIL

*flywheel	Naturally Aspirated	Forced Induction
GAS E85	1,300hp 910hp	1,000hp 700hp

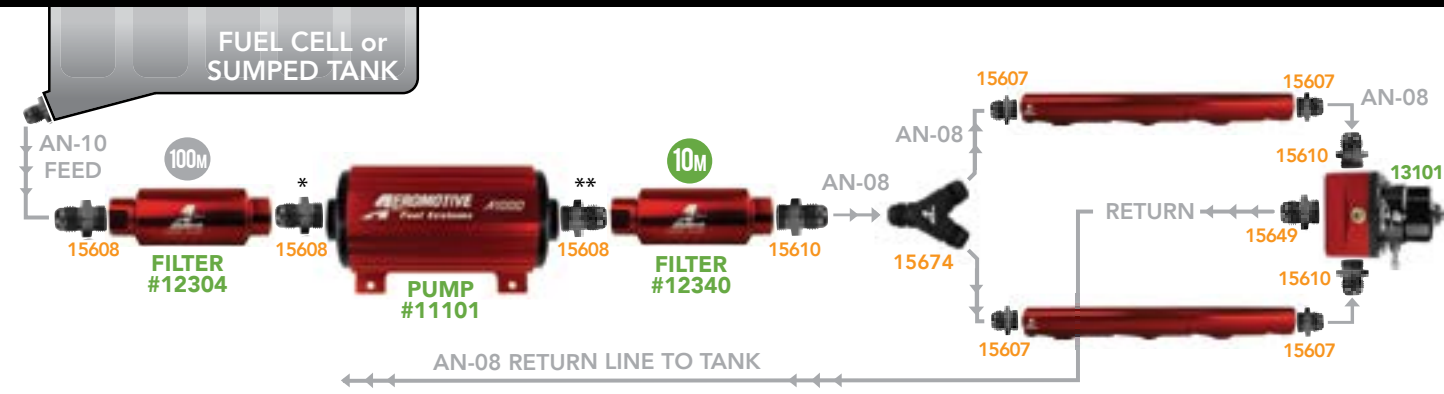

\* Pre Pump : Separate the pump from filter with two #15608 fittings, and -10 line.  
 \*\* Post Pump : Separate the pump from filter with two #15610 fittings, and -08 line.

# A1000

CARBURETED - DUAL FEED - SINGLE CARB

*flywheel	Naturally Aspirated	Forced Induction
GAS E85	1,500hp 1050hp	1,200hp 840hp



\* Pre Pump : Separate the pump from filter with two #15608 fittings, and -10 line.  
 \*\* Post Pump : Separate the pump from filter with two #15608 fittings, and -10 line.

# ELIMINATOR

FUEL INJECTED - DUAL FUEL RAIL

*flywheel	Naturally Aspirated	Forced Induction
GAS E85	1,900hp 1,330hp	1,400hp 980hp

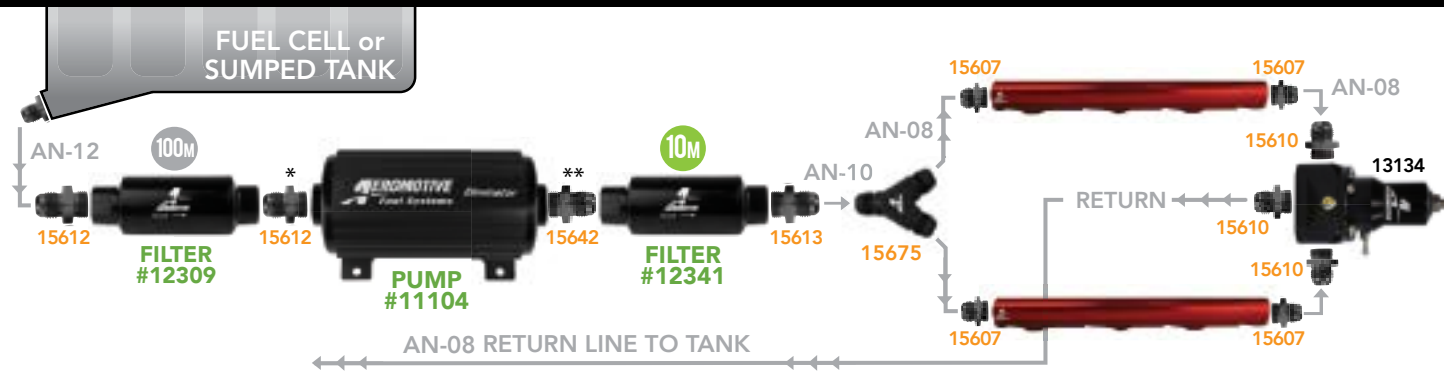

\* Pre Pump : Separate the pump from filter with two #15612 fittings, and -12 line.  
 \*\* Post Pump : Separate the pump from filter with a #15608 fitting, #15613 fitting and -10 line.

# ELIMINATOR

CARBURETED - FUEL LOG

*flywheel	Naturally Aspirated	Forced Induction
GAS E85	2,300hp 1,610hp	1,700hp 1,190hp

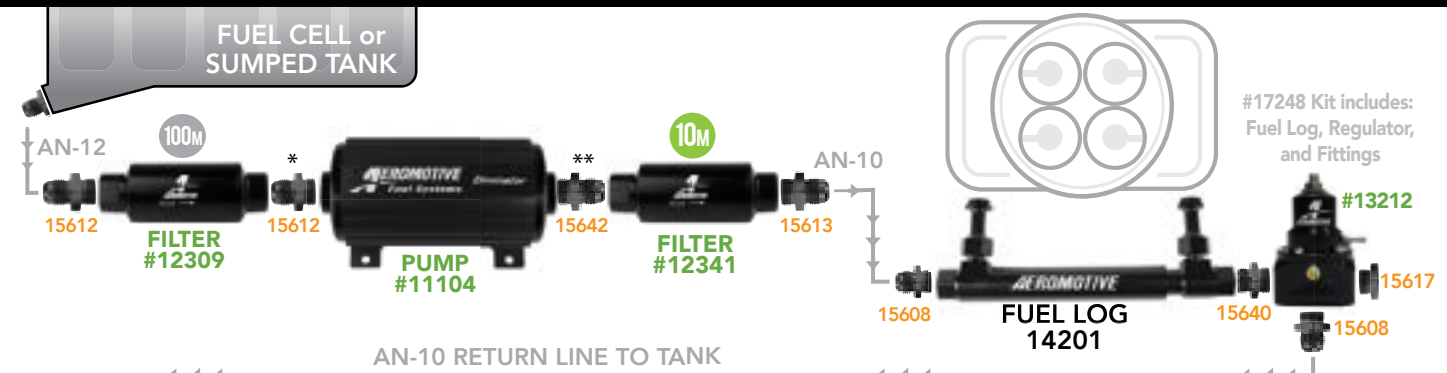

\* Pre Pump : Separate the pump from filter with two #15612 fittings, and -12 line.  
 \*\* Post Pump : Separate the pump from filter with a #15608 fitting, #15613 fitting and -10 line.

# PRO SERIES

FUEL INJECTED - DUAL FUEL RAIL

*flywheel	Naturally Aspirated	Forced Induction
GAS E85	2,200hp 1,540hp	1,700hp 1,190hp

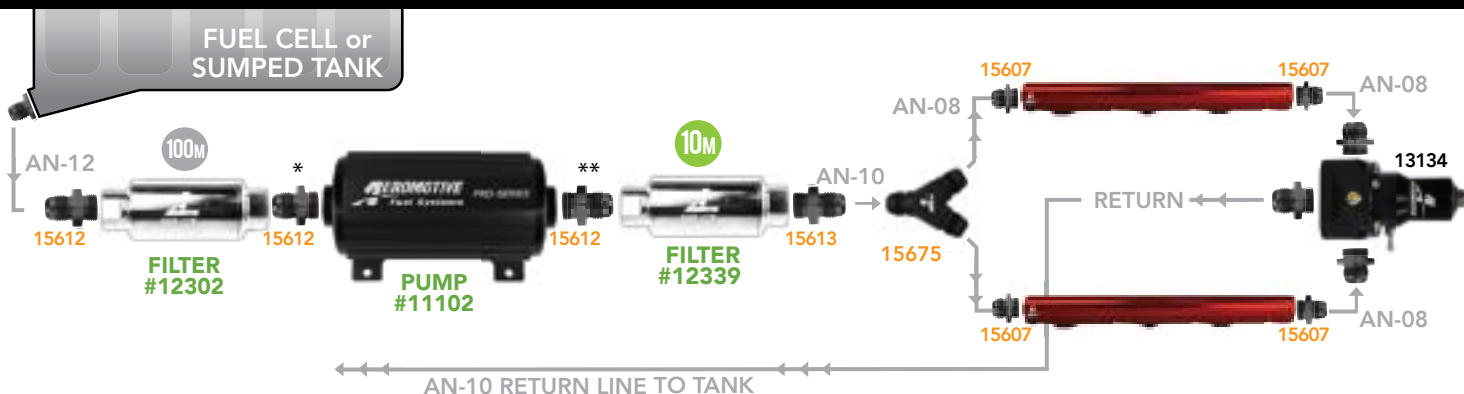

\* Pre Pump : Separate the pump from filter with two #15612 fittings, and -12 line.  
 \*\* Post Pump : Separate the pump from filter with two #15613 fittings and -10 line.

# PRO SERIES

CARBURETED - DUAL FEED - DUAL CARB

*flywheel	Naturally Aspirated	Forced Induction
GAS E85	2,600hp 1,820hp	2,000hp 1,400hp

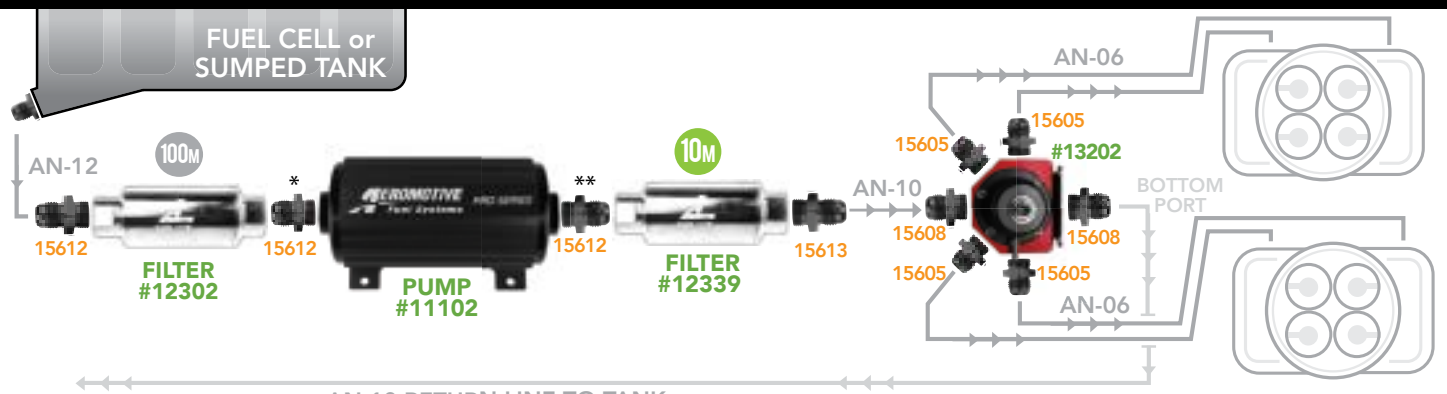

\* Pre Pump : Separate the pump from filter with two #15612 fittings, and -12 line.  
 \*\* Post Pump : Separate the pump from filter with two #15613 fittings and -10 line.

**WARNING** : This product can expose you to chemicals, including chromium, which is known to the State of California to cause cancer or birth defects or other reproductive harm.

**WARNING** : This product can expose you to chemicals, including chromium, which is known to the State of California to cause cancer or birth defects or other reproductive harm.

# BRUSHLESS A1000

FUEL INJECTED - DUAL FUEL RAIL

*flywheel	Naturally Aspirated	Forced Induction
GAS	1,300hp	1,000hp
E85	910hp	700hp

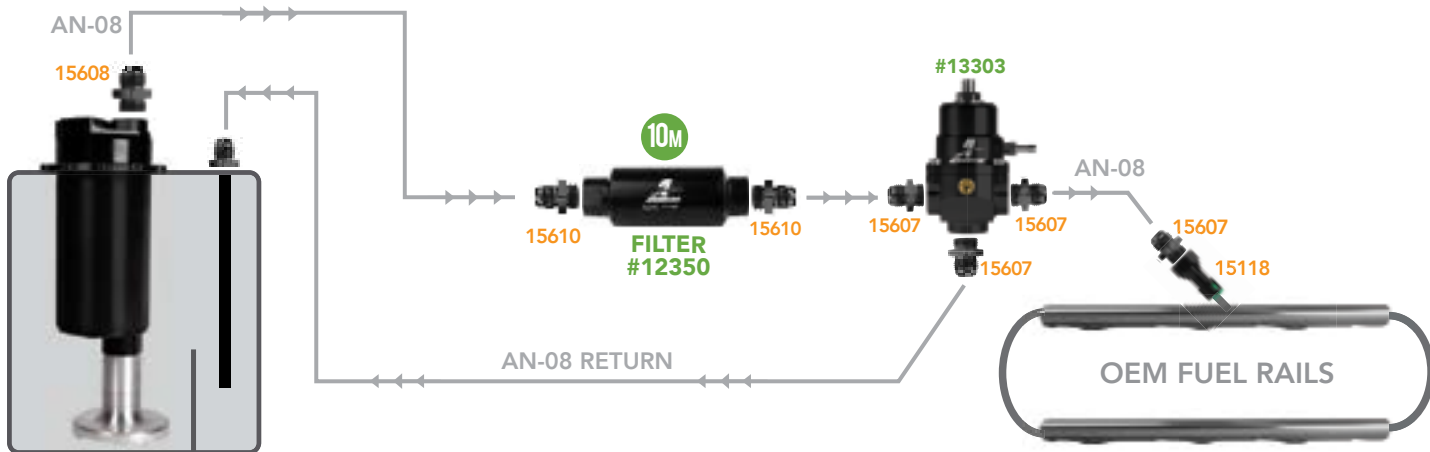

# BRUSHLESS A1000

CARBURETED - DUAL FEED - SINGLE CARB

*flywheel	Naturally Aspirated	Forced Induction
GAS	1,500hp	1,200hp
E85	1050hp	840hp



\* Pre Pump : Separate the pump from filter with two #15608 fittings, and -10 line.  
 \*\* Post Pump : Separate the pump from filter with two #15608 fittings, and -10 line.

# BRUSHLESS ELIMINATOR

FUEL INJECTED - DUAL FUEL RAIL

*flywheel	Naturally Aspirated	Forced Induction
GAS	1,900hp	1,400hp
E85	1,330hp	980hp

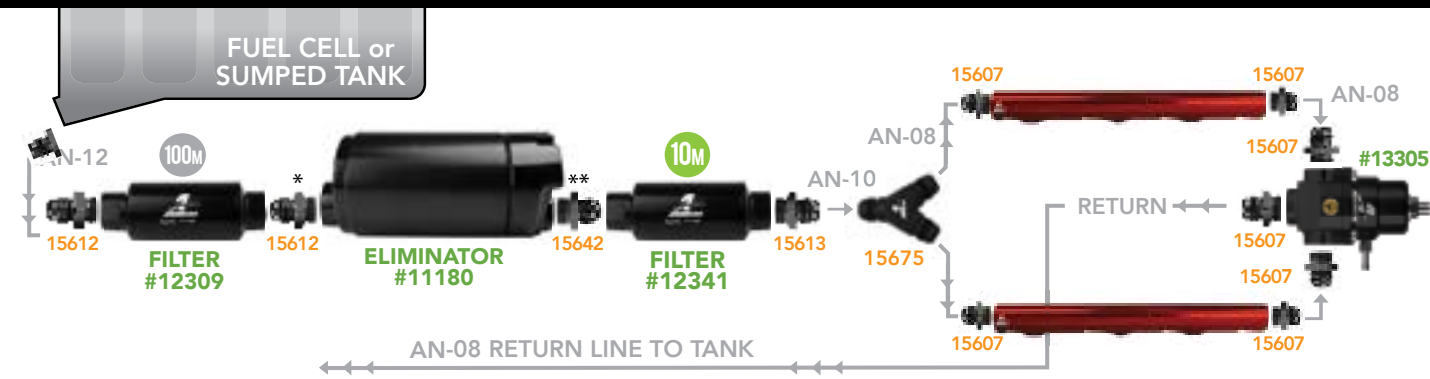

\* Pre Pump : Separate the pump from filter with two #15612 fittings, and -12 line.  
 \*\* Post Pump : Separate the pump from filter with a #15608 fitting, #15613 fitting and -10 line.

# BRUSHLESS ELIMINATOR

CARBURETED - DUAL FEED - SINGLE CARB

*flywheel	Naturally Aspirated	Forced Induction
GAS	2,300hp	1,700hp
E85	1,610hp	1,190hp

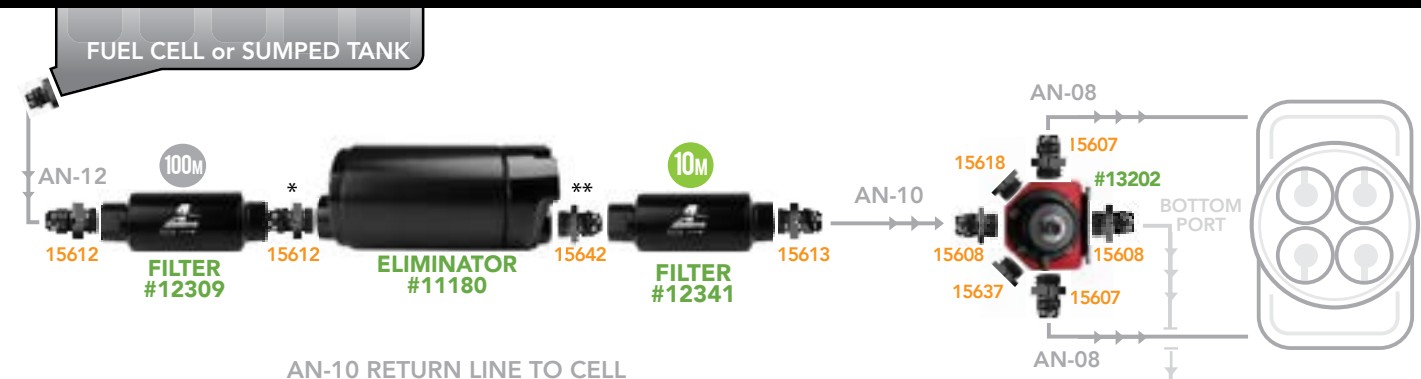

\* Pre Pump : Separate the pump from filter with two #15612 fittings, and -12 line.  
 \*\* Post Pump : Separate the pump from filter with a #15608 fitting, #15613 fitting and -10 line.

# 5.0 BRUSHLESS GEAR PUMP

FUEL INJECTED - DUAL FUEL RAIL

*flywheel	Naturally Aspirated	Forced Induction
GAS	3,400hp	2,600hp
E85	2,380hp	1,820hp

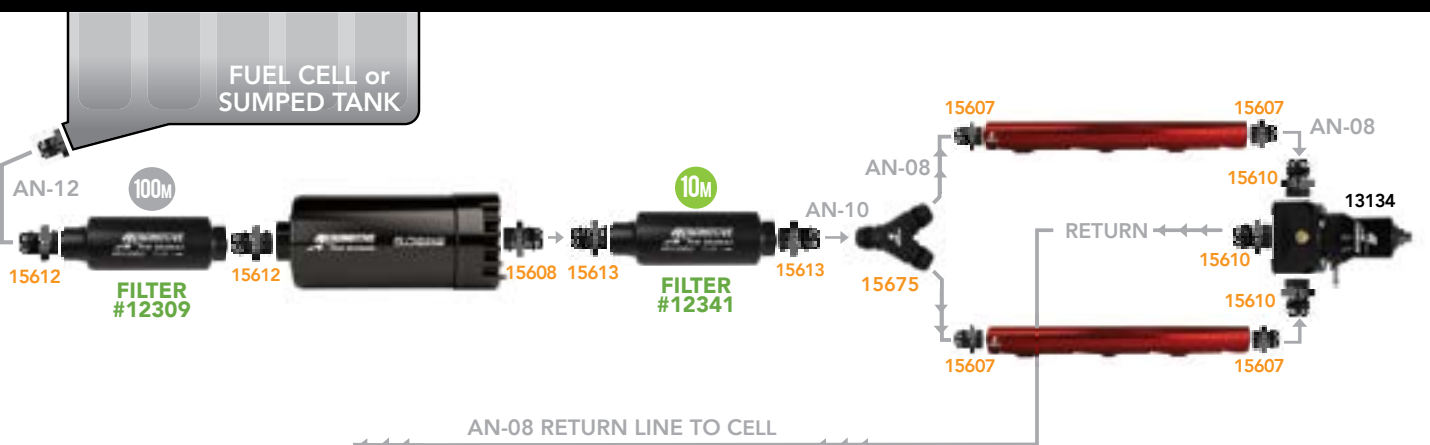

# 3.5 BRUSHLESS GEAR PUMP

CARBURETED - DUAL FEED - DUAL CARB

*flywheel	Naturally Aspirated	Forced Induction
GAS	2,600hp	2,000hp
E85	1,820hp	1,400hp

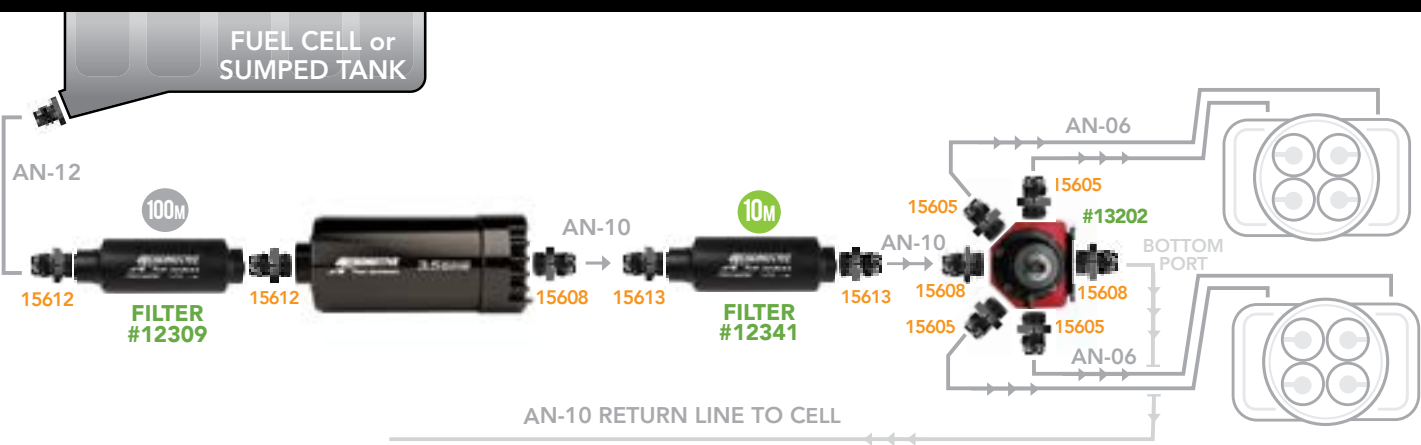

# STEALTH 340

FUEL INJECTED - DUAL FUEL RAIL

*flywheel	Naturally Aspirated	Forced Induction
GAS	850hp	700hp
E85	595hp	490hp

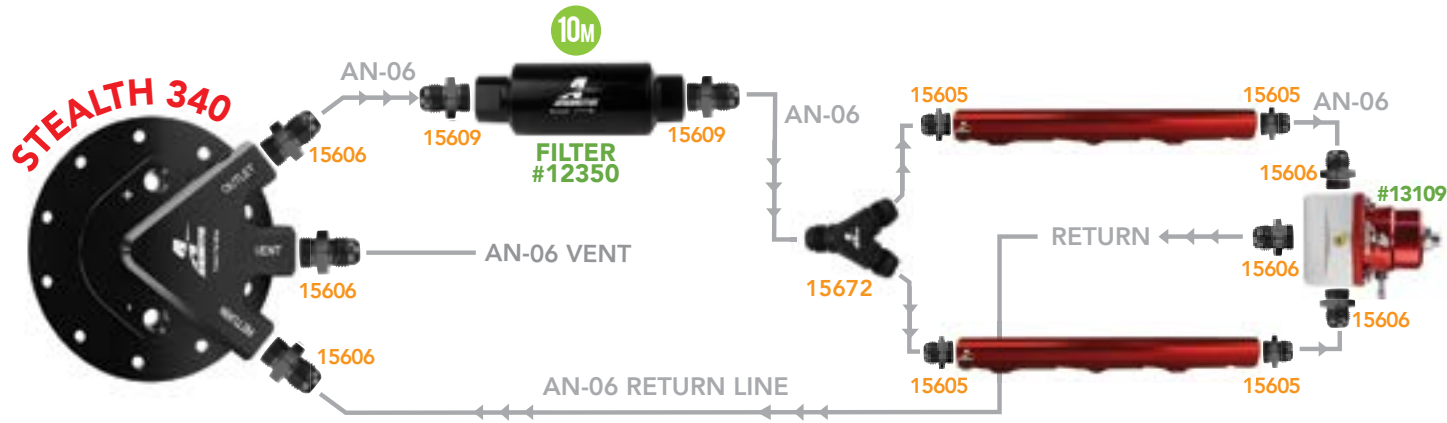

# STEALTH 340

THROTTLE BODY EFI CONVERSION

*flywheel	Naturally Aspirated	Forced Induction
GAS	850hp	700hp

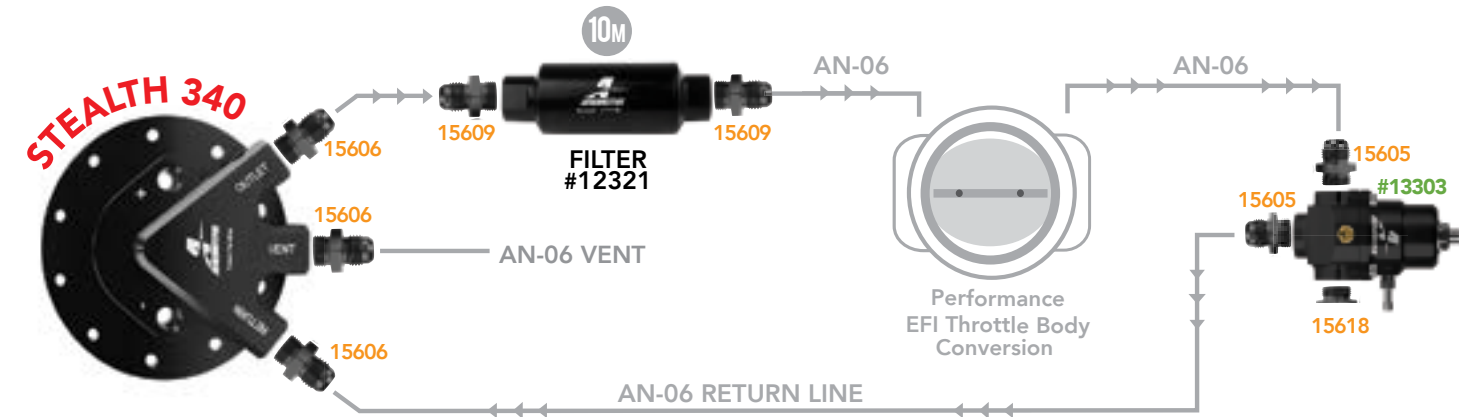

# STEALTH 340

FUEL INJECTED - OEM FUEL RAIL

*flywheel	Naturally Aspirated	Forced Induction
GAS	850hp	700hp

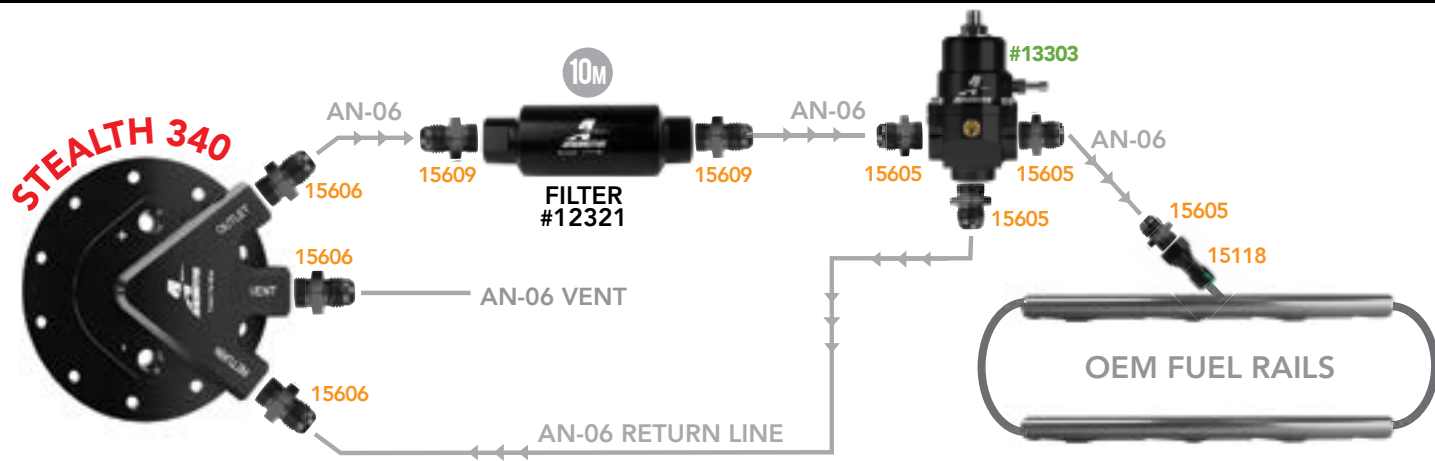

# STEALTH 340

CARBURETED - DUAL FEED - SINGLE CARB

*flywheel	Naturally Aspirated	Forced Induction
GAS	1,000hp	850hp

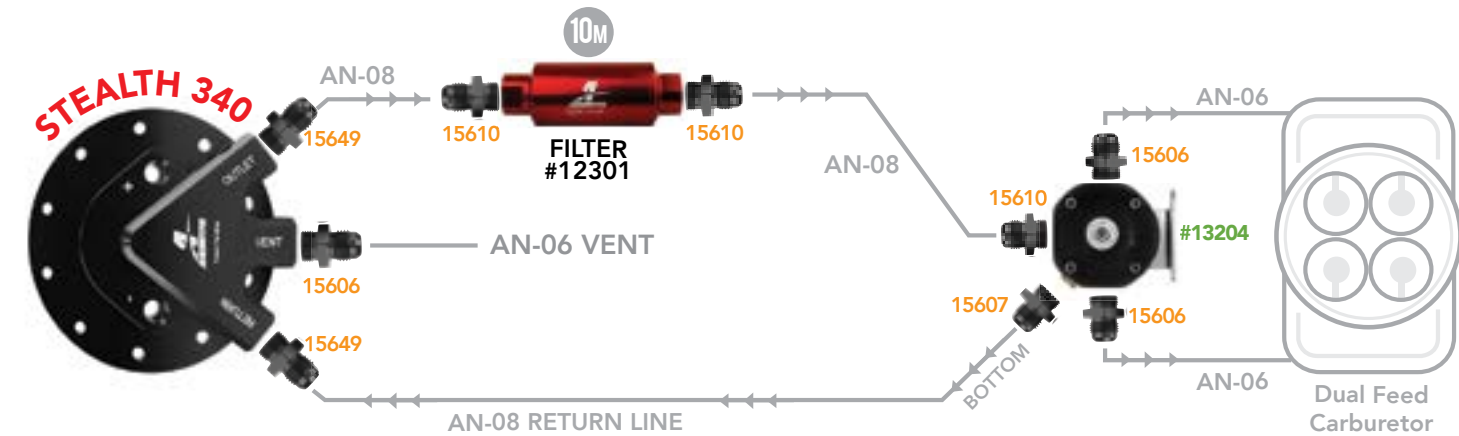

# STEALTH 340

FUEL INJECTED - SINGLE FUEL RAIL

*flywheel	Naturally Aspirated	Forced Induction
GAS	850hp	700hp

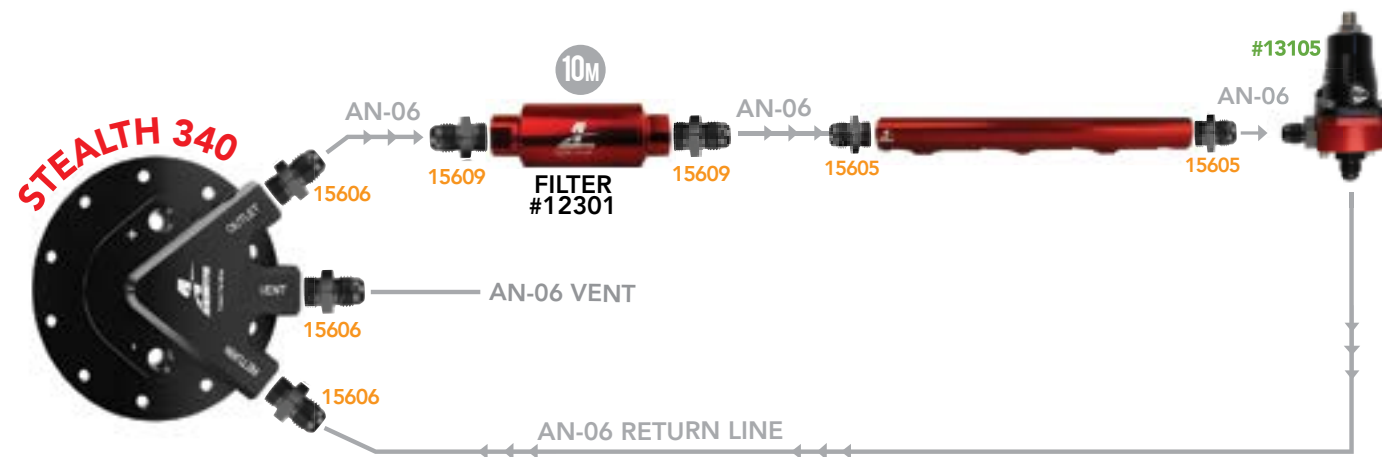

# STEALTH 340

CARBURETED - TWO STAGE NITROUS

*flywheel	Naturally Aspirated	Forced Induction
GAS	1,000hp	850hp

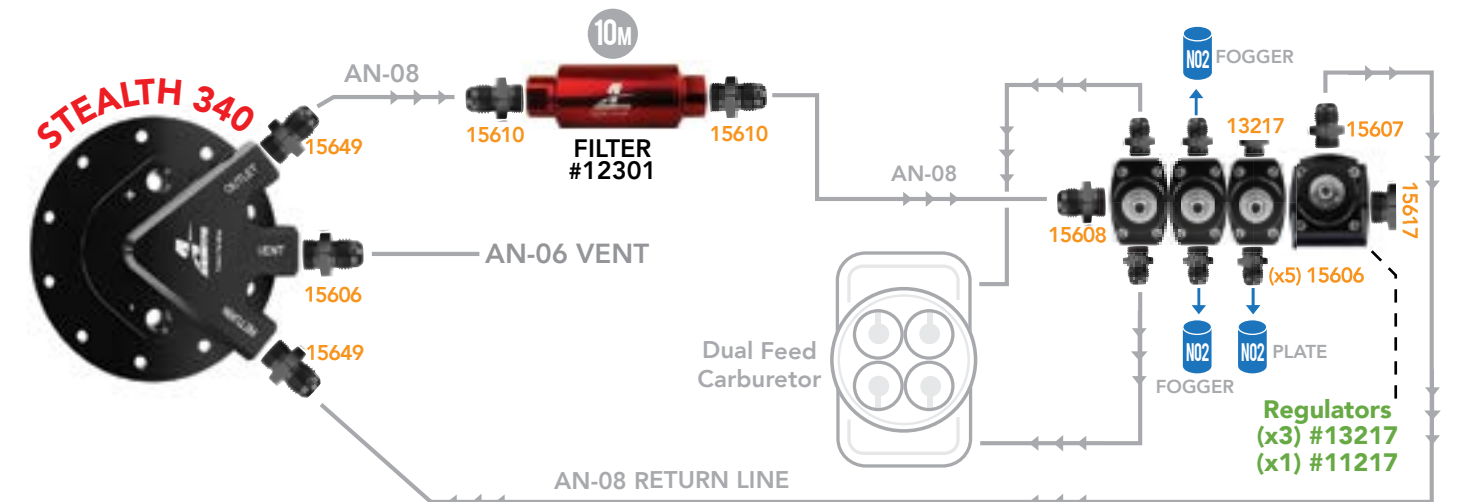

**WARNING:** This product can expose you to chemicals, including chromium, which is known to the State of California to cause cancer or birth defects or other reproductive harm.

**WARNING:** This product can expose you to chemicals, including chromium, which is known to the State of California to cause cancer or birth defects or other reproductive harm.



# PHANTOM FLEX

FUEL INJECTED - DUAL FUEL RAIL

*flywheel	Naturally Aspirated	Forced Induction
GAS	1,100hp	800hp
E85	750hp	550hp

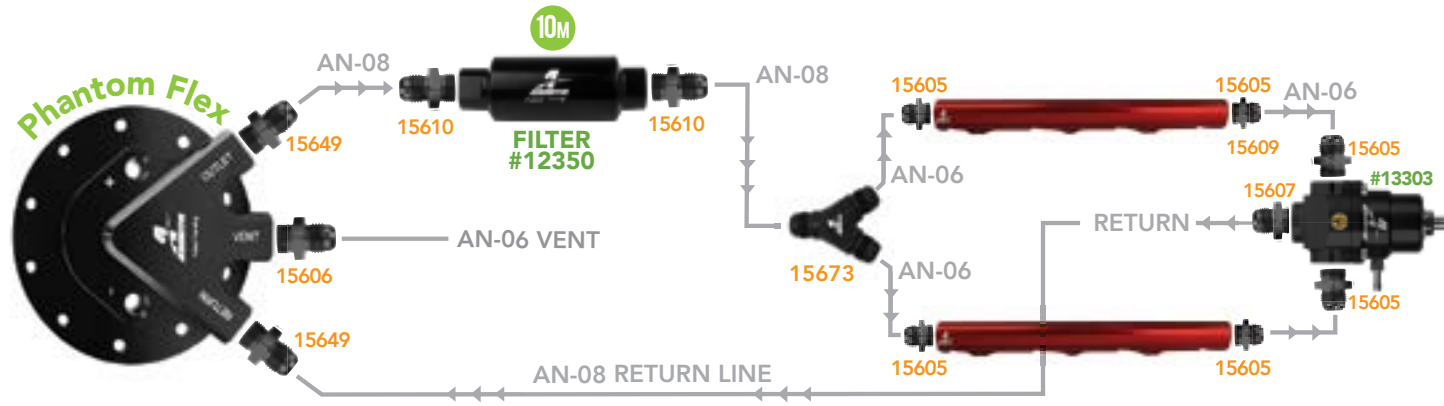

# PHANTOM FLEX

CARBURETED - FUEL LOG

*flywheel	Naturally Aspirated	Forced Induction
GAS	1,300hp	950hp
E85	900hp	700hp

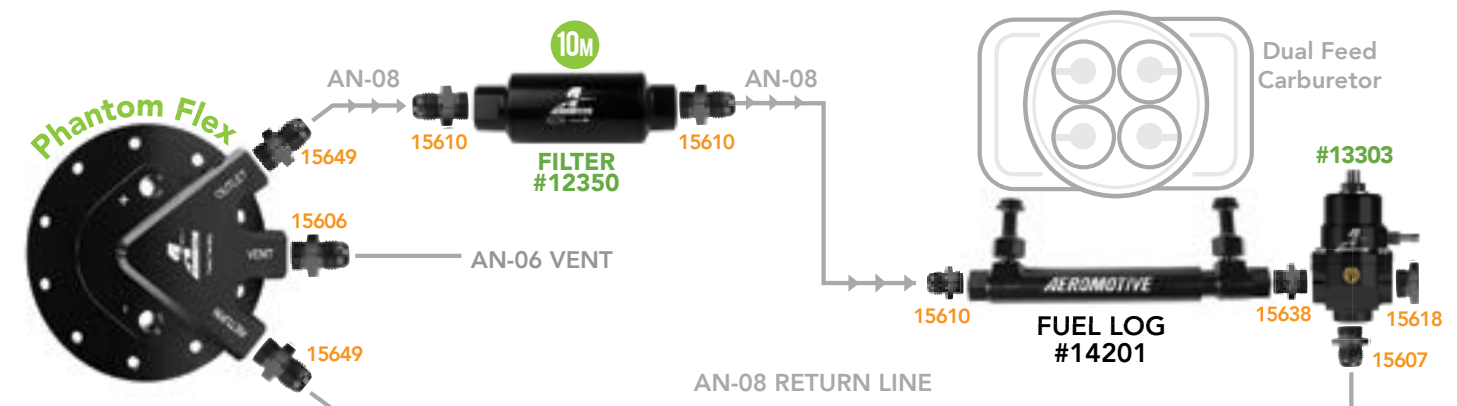

# DUAL PHANTOM

FUEL INJECTED - REDUNDANT - DUAL RAIL

*flywheel	Naturally Aspirated	Forced Induction
GAS	850hp	700hp

The following diagram is for ONE pump to run at a time.

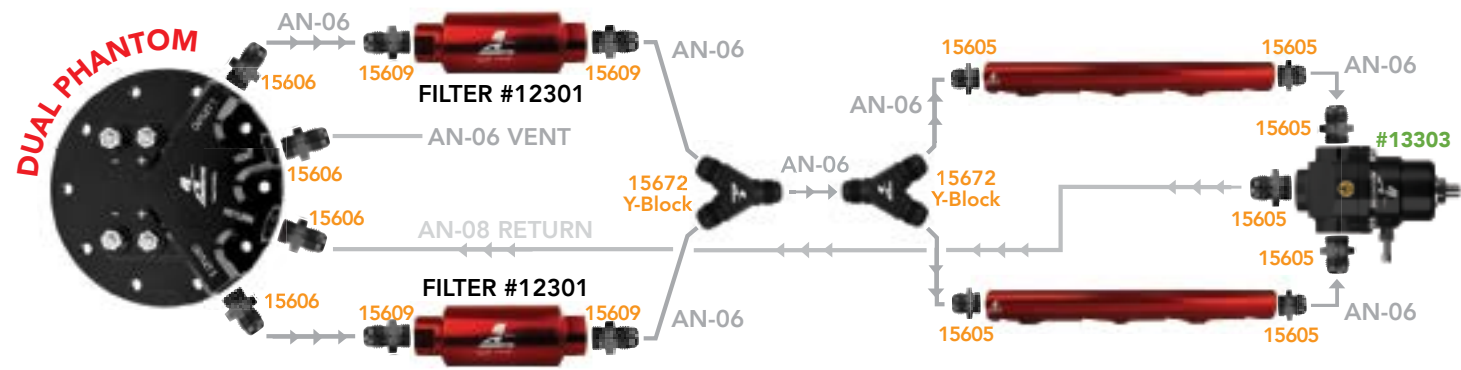

# DUAL PHANTOM

CARBURETED - REDUNDANT - DUAL FEED

*flywheel	Naturally Aspirated	Forced Induction
GAS	1,000hp	850hp

The following diagram is for ONE pump to run at a time.

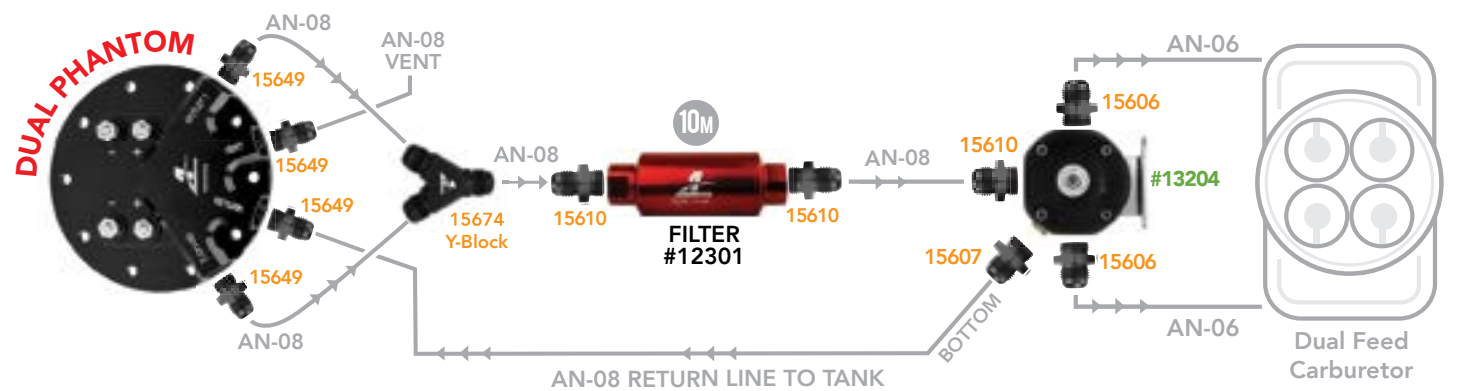

# DUAL PHANTOM

FUEL INJECTED - STAGED - DUAL RAIL

*flywheel	Naturally Aspirated	Forced Induction
GAS	1,700hp	1,400hp
E85	1,190hp	980hp

The following diagram is for BOTH pumps to run at once

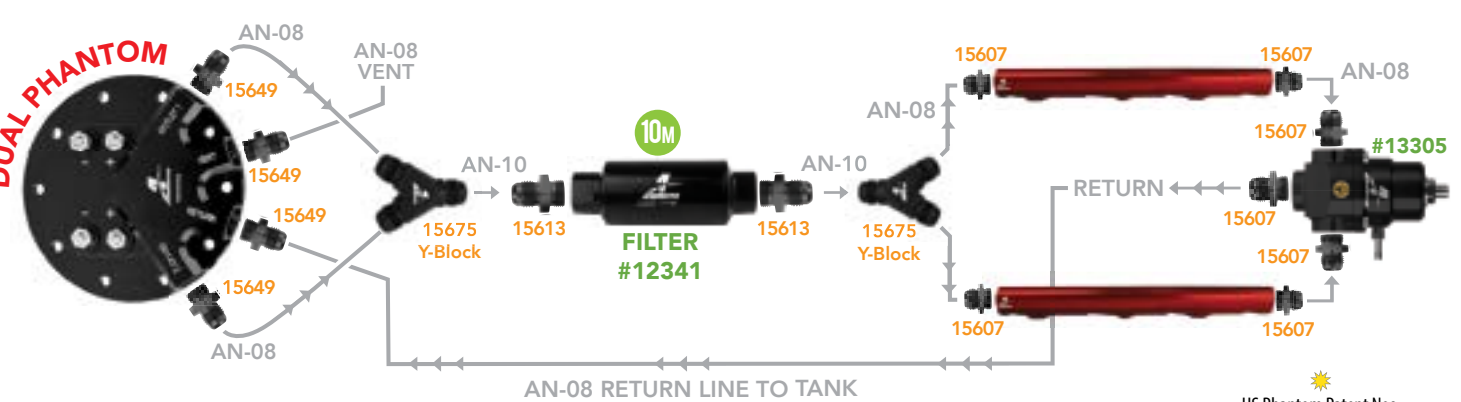

US Phantom Patent Nos.  
8,783,287  
9,567,954

# TRIFEKTA PHANTOM

FUEL INJECTED - STAGED - DUAL RAIL

*flywheel	Naturally Aspirated	Forced Induction
GAS	3,300hp	2,400hp
E85	2,250hp	1,650hp

The following diagram is for ALL pumps to run at once

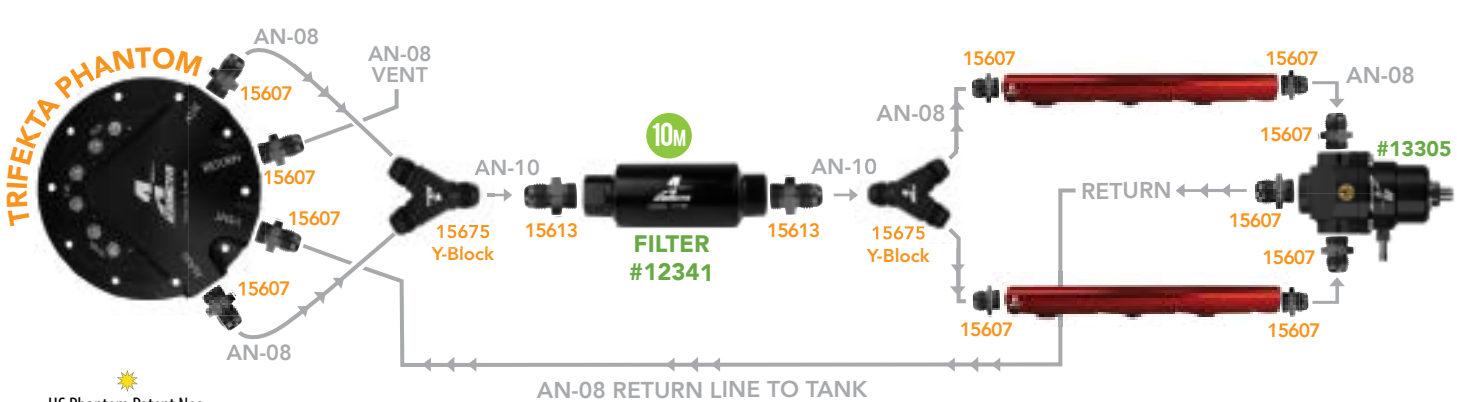

US Phantom Patent Nos.  
8,783,287  
9,567,954

**WARNING:** This product can expose you to chemicals, including chromium, which is known to the State of California to cause cancer or birth defects or other reproductive harm.

**WARNING:** This product can expose you to chemicals, including chromium, which is known to the State of California to cause cancer or birth defects or other reproductive harm.

# A1000

FUEL INJECTED - DUAL FUEL RAIL

*flywheel	Naturally Aspirated	Forced Induction
GAS	1,300hp	1,000hp

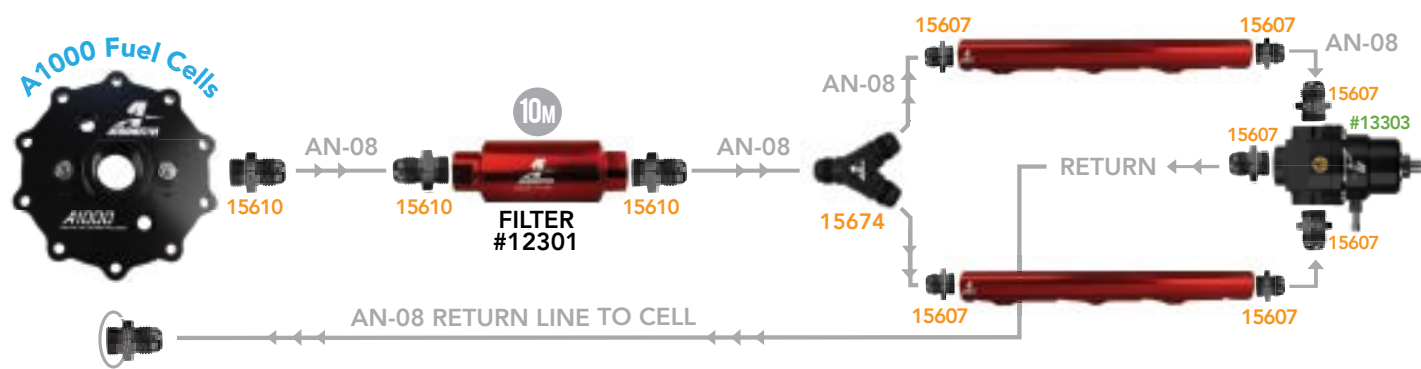

# A1000

CARBURETED - DUAL FEED - SINGLE CARB

*flywheel	Naturally Aspirated	Forced Induction
GAS	1,500hp	1,200hp

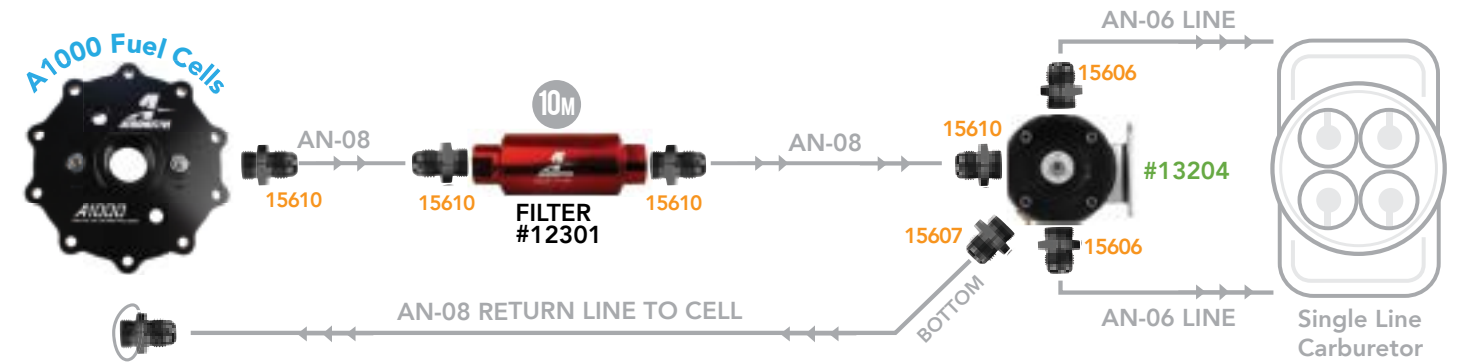

# ELIMINATOR

FUEL INJECTED - DUAL FUEL RAIL

*flywheel	Naturally Aspirated	Forced Induction
GAS	1,900hp	1,400hp
E85	1,330hp	980hp

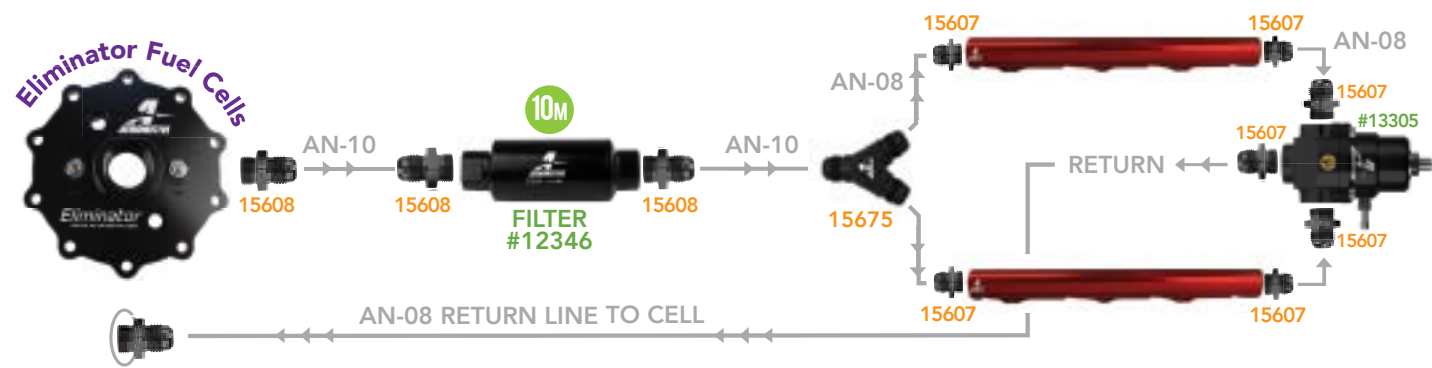

# ELIMINATOR

CARBURETED - DUAL FEED - SINGLE CARB

*flywheel	Naturally Aspirated	Forced Induction
GAS	2,300hp	1,700hp
E85	1,610hp	1,190hp

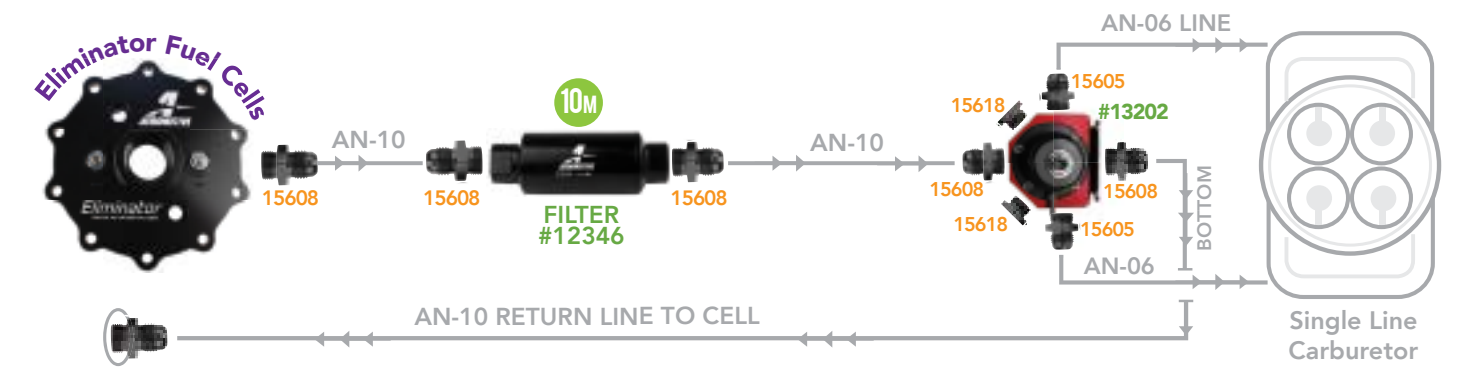

# ELIMINATOR

CARBURETED - FUEL LOG

*flywheel	Naturally Aspirated	Forced Induction
GAS	2,300hp	1,700hp
E85	1,610hp	1,190hp

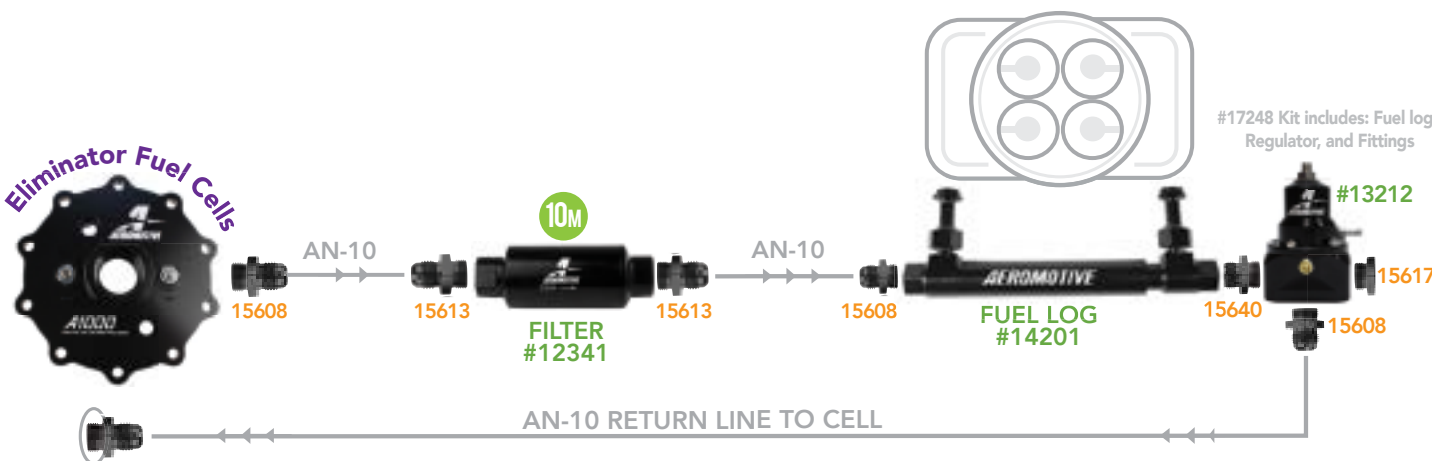

# ELIMINATOR

CARBURETED - NITROUS - STACKABLE REGULATORS

*flywheel	Naturally Aspirated	Nitrous
GAS	2,300hp	1,700hp
E85	1,610hp	1,190hp

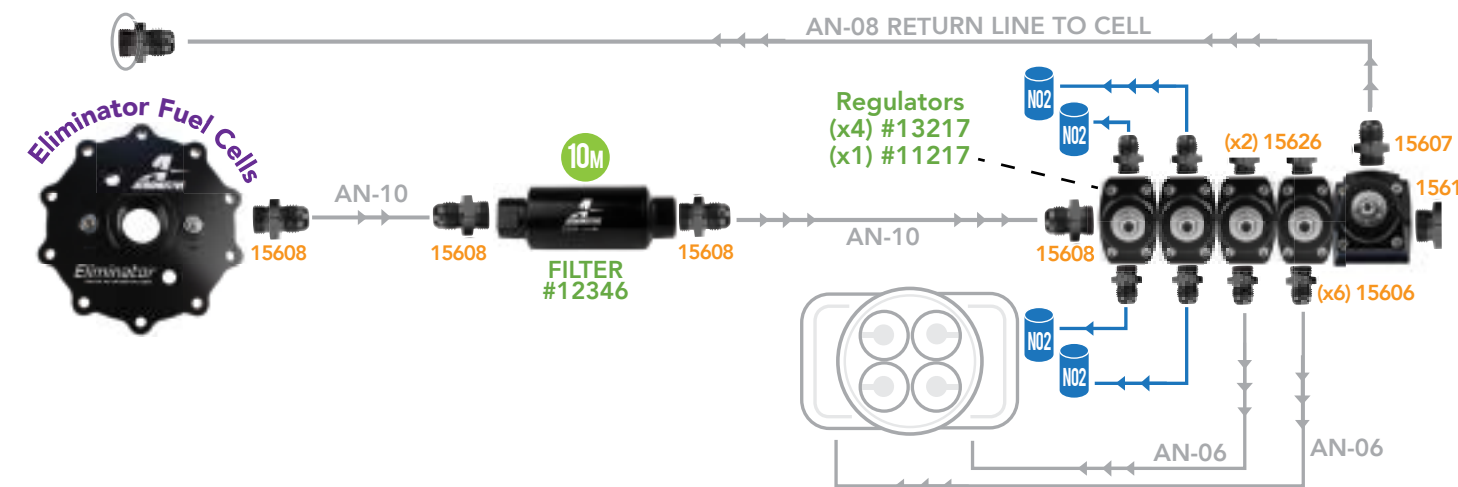

**WARNING:** This product can expose you to chemicals, including chromium, which is known to the State of California to cause cancer or birth defects or other reproductive harm.

**WARNING:** This product can expose you to chemicals, including chromium, which is known to the State of California to cause cancer or birth defects or other reproductive harm.

# SS SERIES

15psi DEADHEAD - DUAL FEED - SINGLE CARB

*flywheel	Naturally Aspirated	Forced Induction
GAS E85	750hp 525hp	575hp 400hp

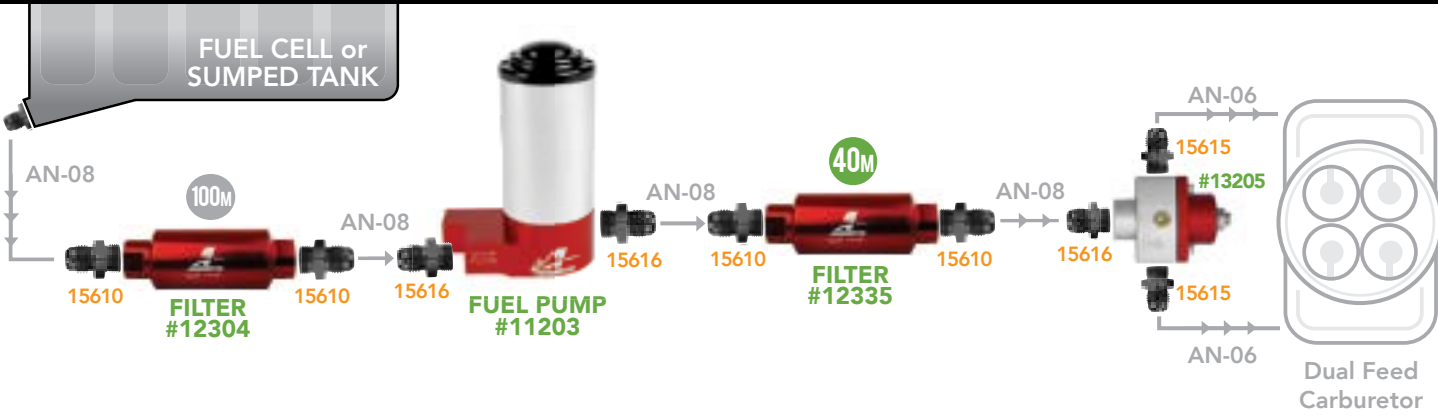

# A2000

BYPASS REGULATOR - DUAL FEED - DUAL CARB

*flywheel	Naturally Aspirated	Forced Induction
GAS E85	2,600hp 1,820hp	2,000hp 1,400hp

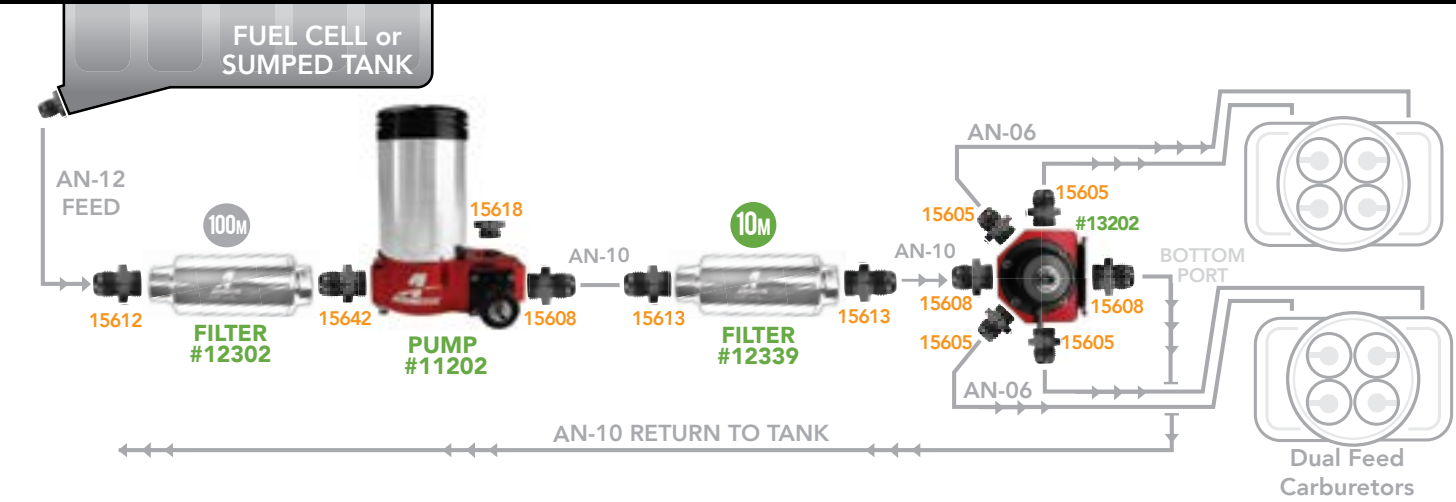

# SS SERIES

15psi DEADHEAD - MULTI SIDE-DRAFT CARBS

*flywheel	Naturally Aspirated	Forced Induction
GAS E85	750hp 525hp	575hp 400hp



# A2000

DEADHEAD REGULATOR - DUAL FEED - SINGLE CARB

*flywheel	Naturally Aspirated	Forced Induction
GAS E85	2,600hp 1,820hp	2,000hp 1,400hp

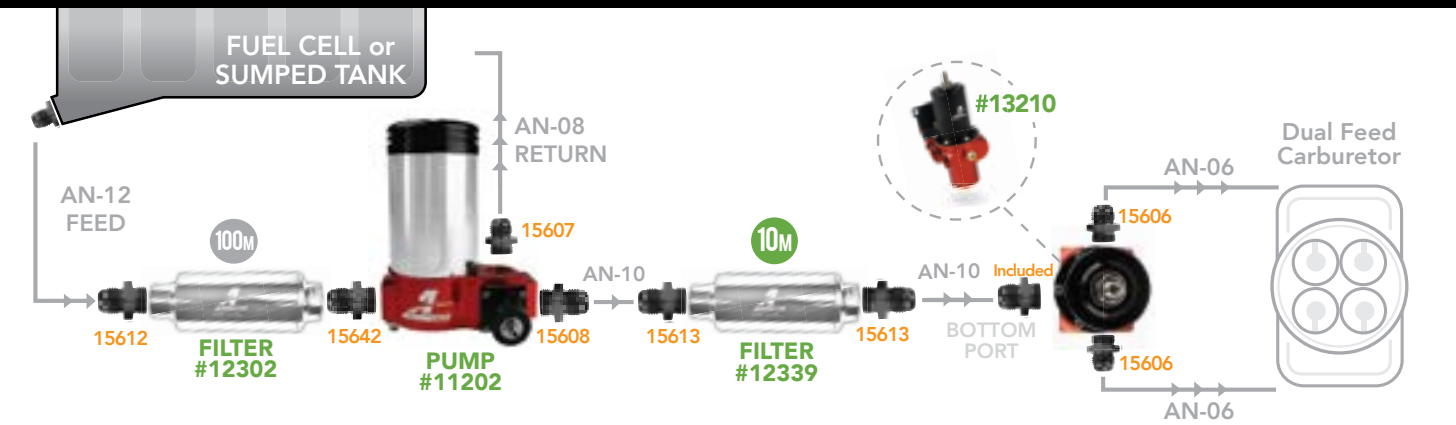

# H.O. SERIES

7psi DEADHEAD - SINGLE FEED CARB

*flywheel	Naturally Aspirated	Forced Induction
GAS E85	550hp 385hp	400hp 280hp



# A3000

STACKABLE REGULATORS - DUAL FEED - DUAL CARB

*flywheel	Naturally Aspirated	Forced Induction
GAS E85	3,600hp 2,520hp	2,800hp 1,960hp

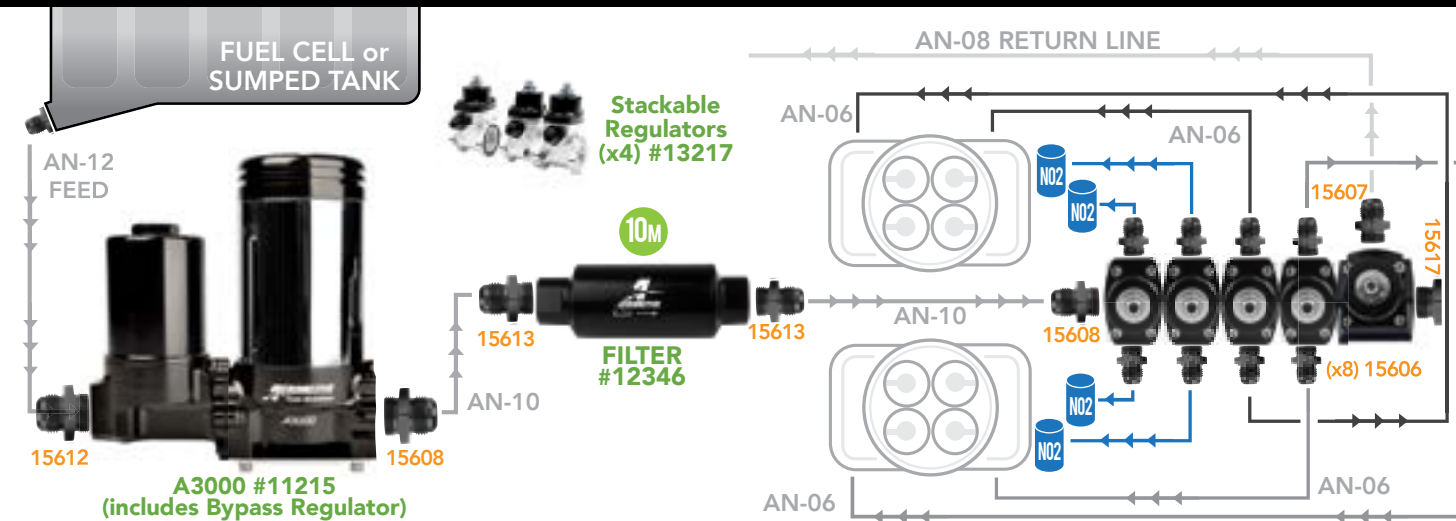

# 12GPM GEROTOR

FUEL INJECTED - DUAL FUEL RAIL

*flywheel	Naturally Aspirated	Forced Induction
GAS	8,000hp	7,000hp
E85	5,600hp	4,900hp
Methanol	3,000hp	2,500hp

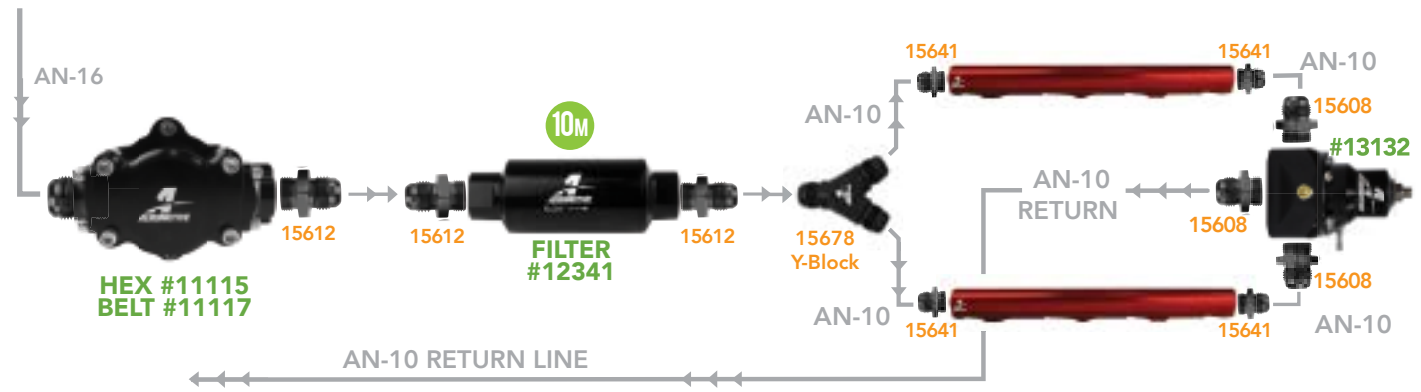

# 6GPM GEROTOR

CARBURETED - DUAL FEED - DUAL CARB

*flywheel	Naturally Aspirated	Forced Induction
GAS	4,000hp	3,600hp
E85	2,800hp	2,520hp
Methanol	1,800hp	1,500hp

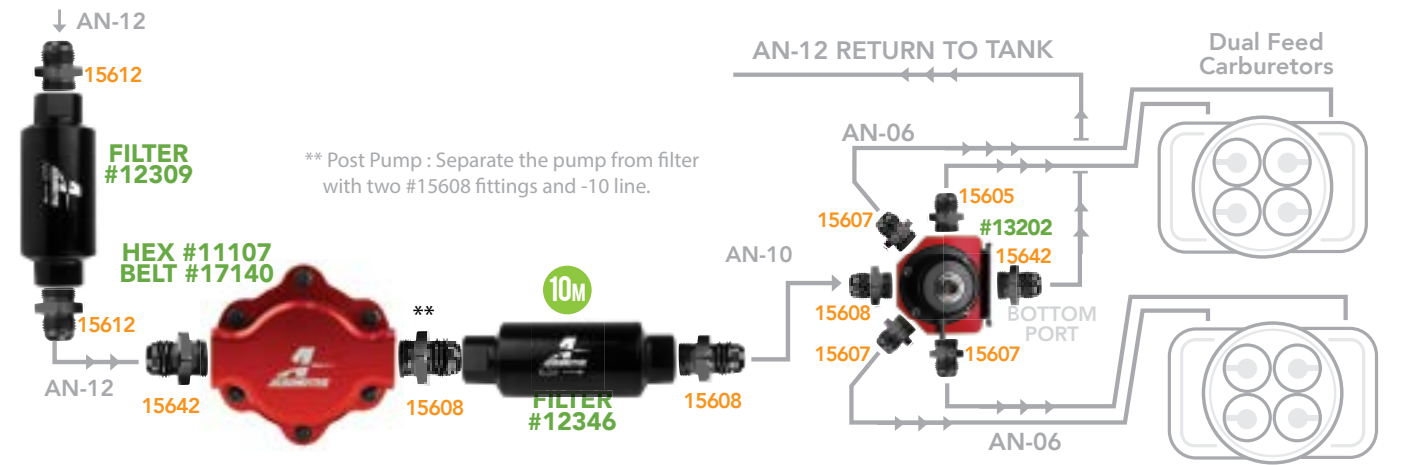

# 6GPM GEROTOR

FUEL INJECTED - DUAL FUEL RAIL

*flywheel	Naturally Aspirated	Forced Induction
GAS	4,000hp	3,600hp
E85	2,800hp	2,520hp
Methanol	1,800hp	1,500hp

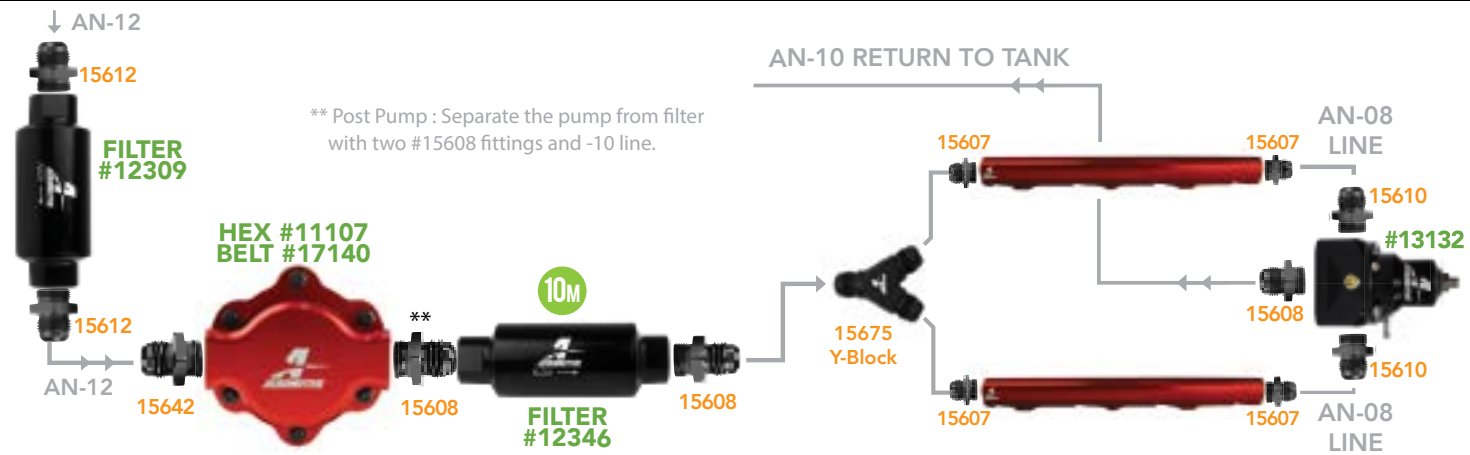

# 6GPM GEROTOR

CARBURETED - STACKABLE REGULATORS - NITROUS

*flywheel	Naturally Aspirated	Forced Induction
GAS	4,000hp	3,600hp
E85	2,800hp	2,520hp
Methanol	1,800hp	1,500hp

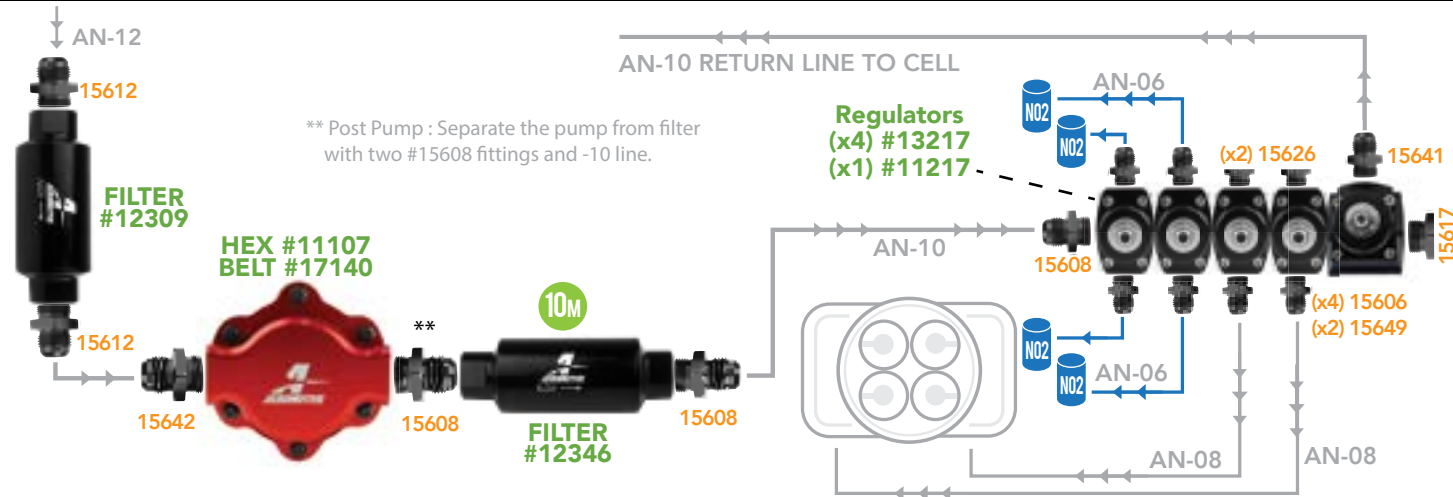

# 6GPM GEROTOR

FUEL INJECTED - PHANTOM SUPPORTED

*flywheel	Naturally Aspirated	Forced Induction
GAS	4,000hp	3,600hp
E85	2,800hp	2,520hp
Methanol	1,800hp	1,500hp

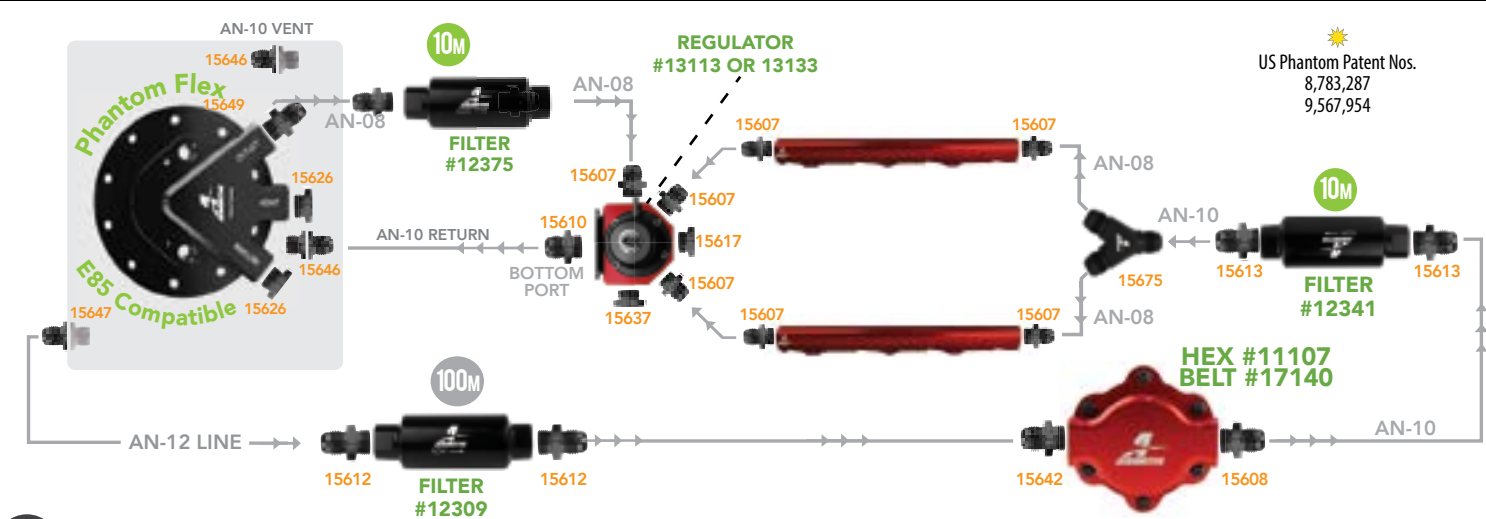

# 6GPM GEROTOR

CARBURETED - DOUBLE ADJUSTABLE REGULATOR

*flywheel	Naturally Aspirated	Forced Induction
GAS	4,000hp	3,600hp
E85	2,800hp	2,520hp
Methanol	1,800hp	1,500hp

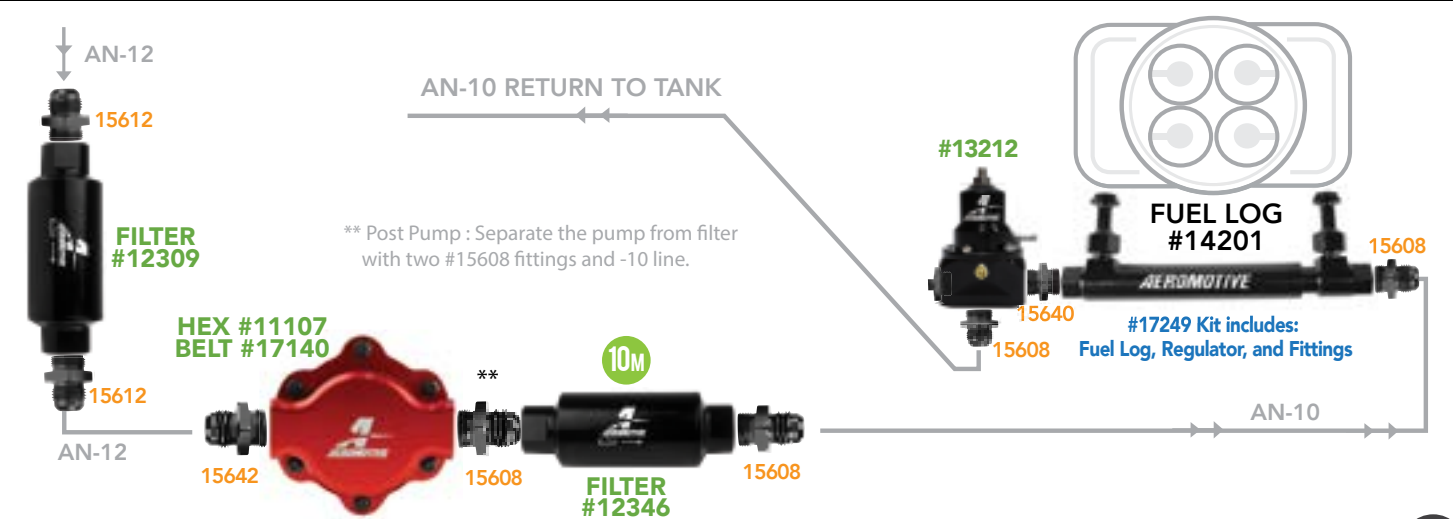

**WARNING :** This product can expose you to chemicals, including chromium, which is known to the State of California to cause cancer or birth defects or other reproductive harm.

Discover other boat fuel systems on our website.