



advanced FLOW engineering

Instruction Manual P/N: 46-20468-B

BladeRunner – Charge Pipe Kit

Make: Jeep

Model: Wrangler JL

Year: 2018-2021

Engine: L4 – 2.0L(t)



- Please read the entire instruction manual before proceeding.
- Ensure all components listed are present.
- If you are missing any of the components, call customer support.
- Ensure you have all necessary tools before proceeding.
- Do not attempt to work on your vehicle when the engine is hot.
- Disconnect the negative battery terminal before proceeding.
- Retain factory parts for future use.

Label	Qty.	Description	Part Number
A	1	Tube, Hot Side: 46-20468-B	05-61152B
B	1	Coupling, Silicone Rdr Elbw: 2.75" x 2.5" 45Deg	05-61153
C	1	Coupling, Silicone Reducer: 2" ID x 5.6"L 10Deg	05-61154
D	4	Clamp, SmartSeal, 044 (2.5" – 3.06")	03-50656
E	3	Screw, Socket Head Cap: M6x1.0x20, S/S	03-50241
F	3	Washer, M6 (12mm OD x 6.4mm ID)	03-50177
G	1	Screw, Btn Hd Socket: M6x1x12	03-50102
H	1	Plug, Hex Hd Socket: 1/8" NPT (Zn Plt)	03-50029
I	2	Screw, Hex Flange: M6 x 1.0 x 50	03-50661
J	2	Spacer: 22mm OD x 30mm L	05-61147

Installation will require the following tools:

7mm socket, 8mm socket, 10mm socket, 19mm wrench, T20 Torx, 5mm allen wrench, 5/32" allen wrench, 3/16" allen wrench, ratchet, plastic pry tool, & pick.

Note: Legal in California for use on race vehicles only. The use of this device on vehicles used on public streets or highways is strictly prohibited in California and others states that have adopted California emission regulations.

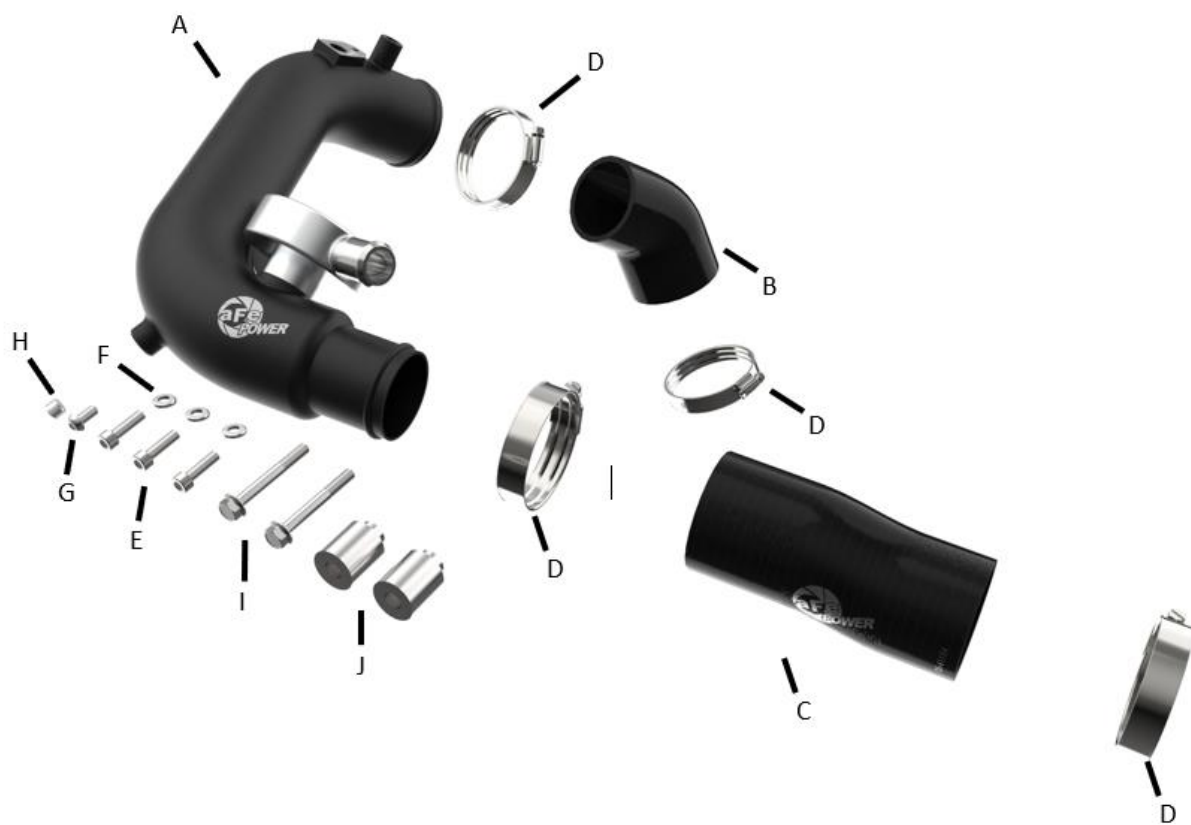



1. Park vehicle on level ground and engage the parking brake.
2. Disconnect the negative battery cable.
3. Loosen the bolts securing the engine cover (1) then lift the cover up from the rear grommets and out of the vehicle.
4. Using a plastic pry tool, remove two clips (2) securing transmission breather hose from the side engine cover.
5. Loosen the screws securing the side engine cover (3) and remove the cover from the vehicle.

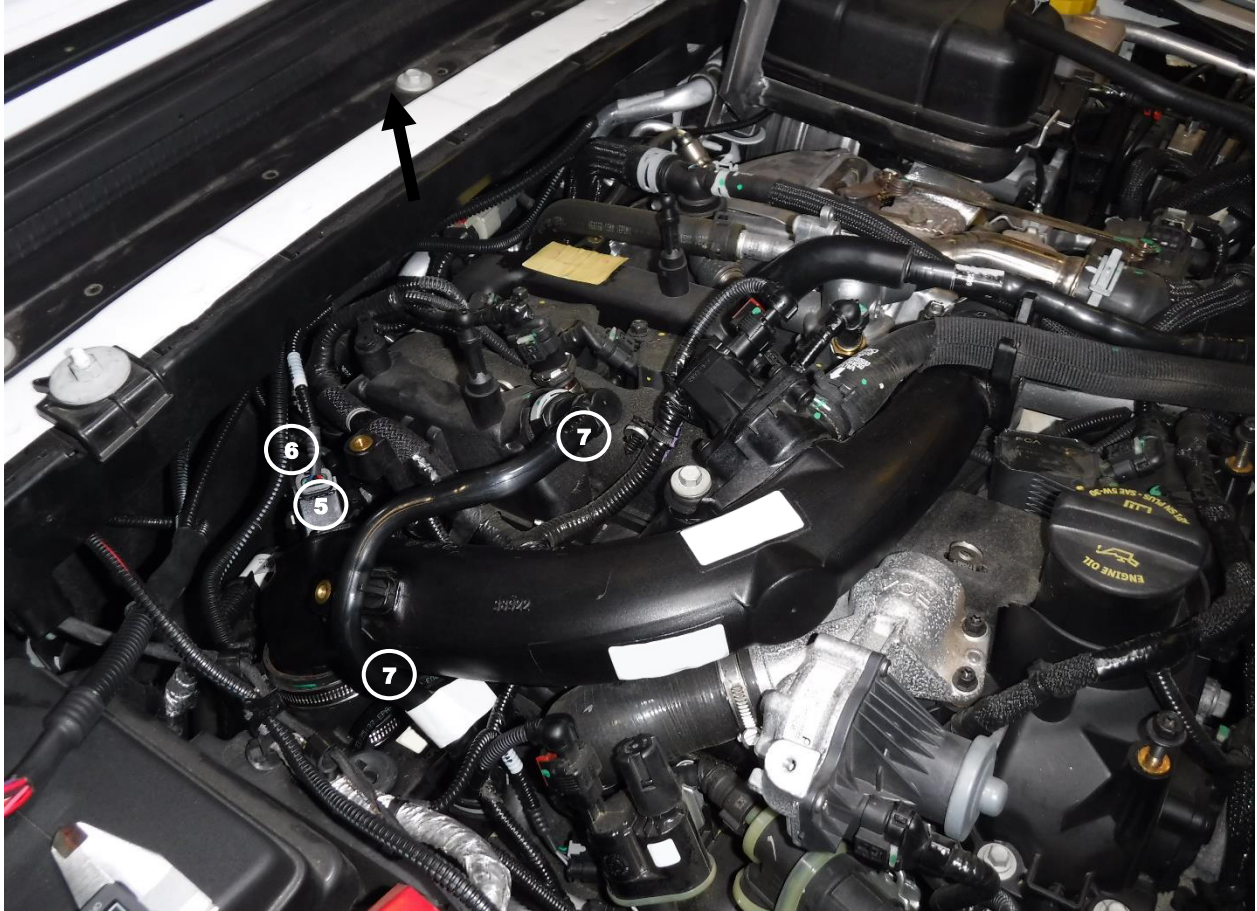

6. Release the security tab on the MAP sensor connector, then disconnect it from the charge pipe ⑤
7. Release the security tab on the temperature sensor connector, then disconnect it from the charge pipe ⑥
8. Remove the vent tube from the vehicle by depressing the release clip and separating connections ⑦



9. Remove the screw securing the charge pipe to the vehicle (8)
10. Release the security tab on the blow off valve actuator connector, then disconnect it from the charge pipe (9)
11. Disconnect the charge air recirculation hose from the charge pipe and set it to the side (10)
12. Disconnect the PCV hose from the PCV valve by squeezing the ribbed areas of the connector, then separating the connection and set the hose to the side (11)

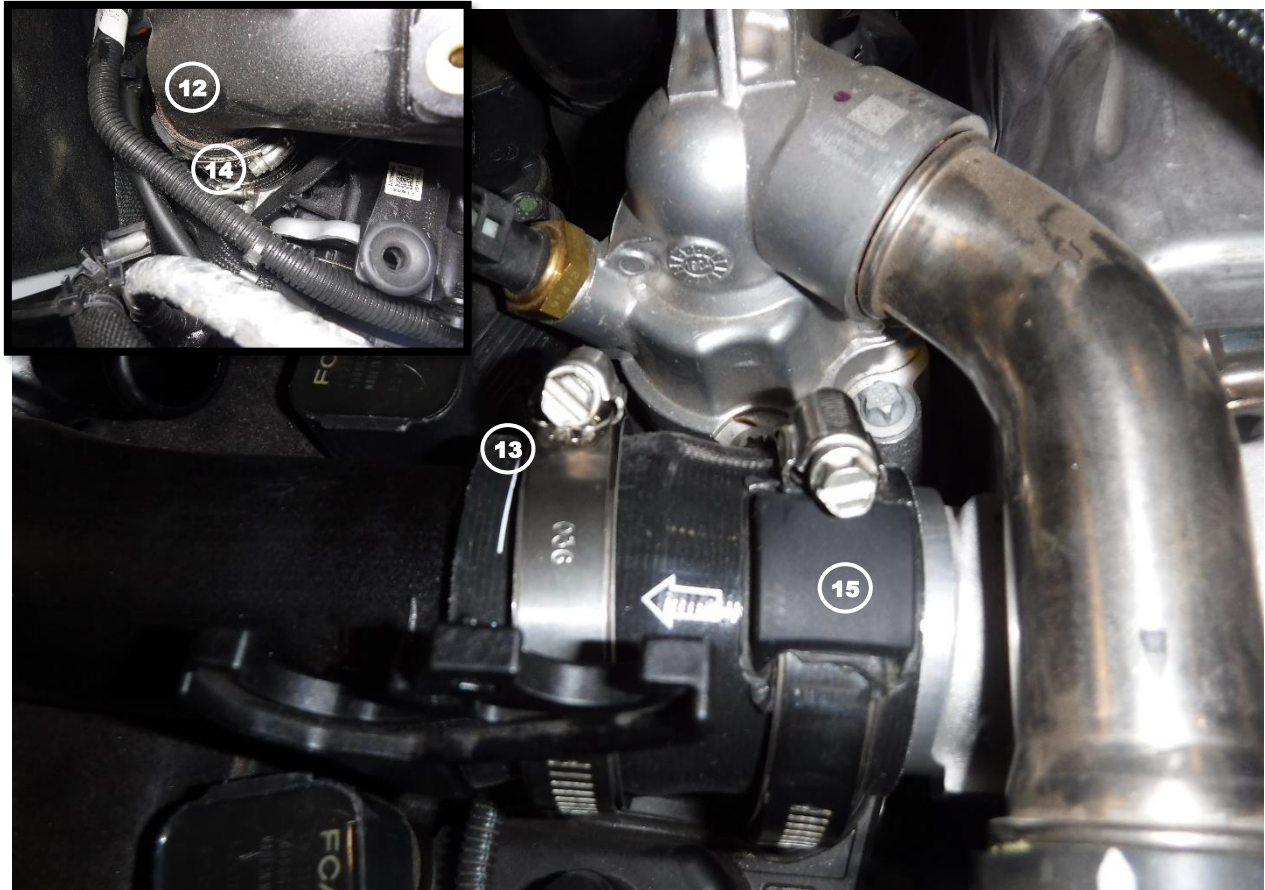

13. Loosen the clamp securing the throttle body coupling onto the charge pipe (12)

14. Loosen the clamp securing the turbo coupling to the charge pipe (13)

It may be necessary to use a pick to break the connection between the charge pipe couplings and the vehicle in order to disconnect the couplings.

15. Remove the charge pipe from the vehicle.

16. Loosen the clamp securing the throttle body coupling, then remove the coupling from the vehicle (14)

17. Loosen the clamp securing the turbo coupling, then remove the coupling from the vehicle (15)



Note: Be sure to lubricate the O-ring with grease to prevent it from tearing during installation.

18. Transfer the temperature sensor from the factory charge pipe to the supplied aFe charge pipe (16)
19. Transfer the MAP sensor from the factory charge pipe to the supplied aFe charge pipe (17)
20. Secure the MAP sensor to the aFe charge pipe using the M6x1x12 screw.
21. Transfer the blow off valve actuator from the factory charge pipe to the aFe charge pipe (18)
22. Secure the blow off valve actuator sensor to the aFe charge pipe using the supplied M6x1x20 screws along with the M6 washers..

Note: Be sure to use thread sealant on the plug or sensor to prevent any leaking.

23. If you are not using an aftermarket sensor, install the supplied 1/8" NPT plug (19) into the threaded fitting on the aFe charge pipe.
24. Transfer the two factory metal inserts and the mounting gromet from the factory charge pipe to the aFe charge pipe (20)

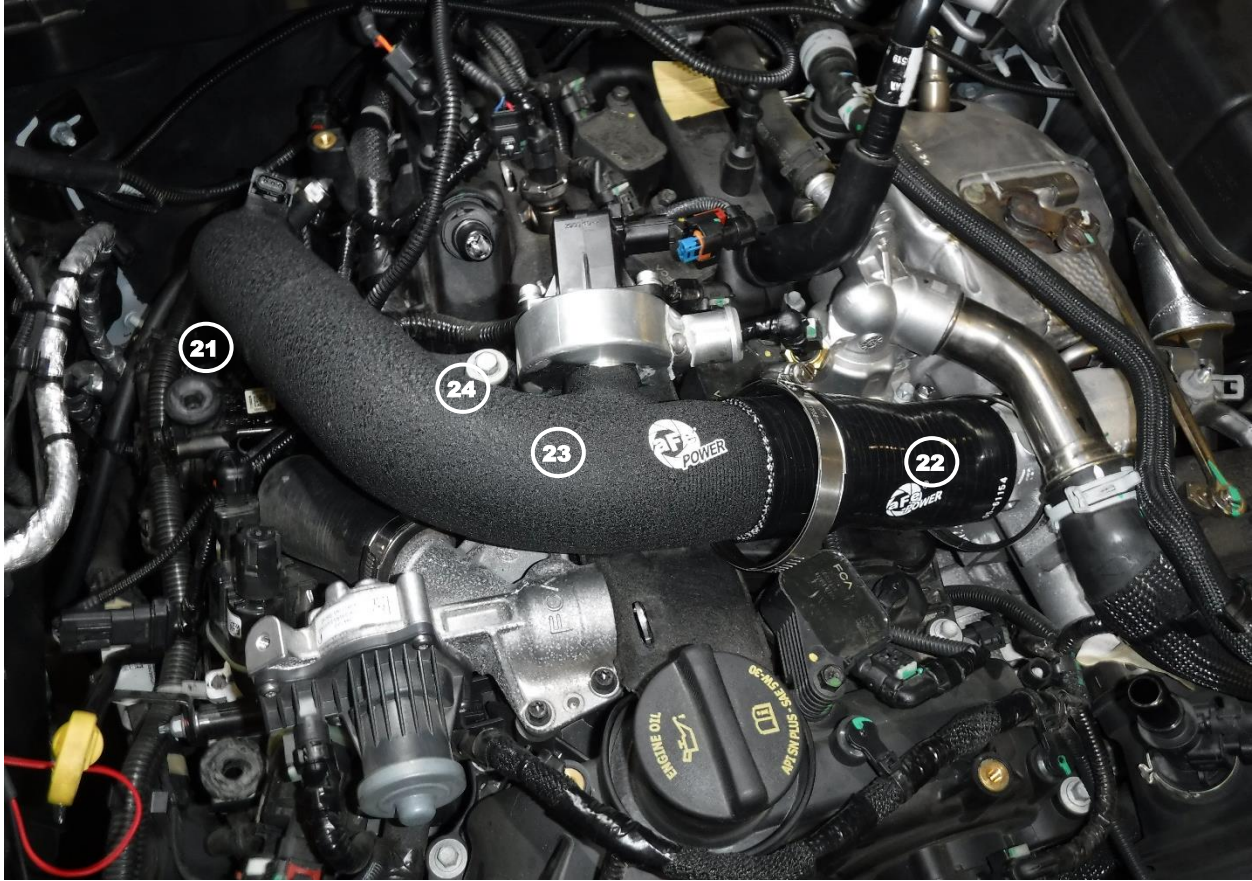

Note: Be sure to thoroughly clean all oil residue off of the connections before installing any of the aFe couplings onto the vehicle.

25. Install the supplied aFe silicone reducer elbow coupling 2.75"ID x 2.5"ID x 45Deg and two SmartSeal, 044 (2.5" – 3.06") clamps onto the throttle body (21) do not tighten the clamp yet.
26. Install the supplied aFe silicone coupling 2" ID x 5.6"L 10Deg and two SmartSeal, 044 (2.5" – 3.06") clamps onto the aFe charge pipe (22) do not tighten the clamp yet.
27. Install the aFe hot side charge pipe into the vehicle (23) Connect the aFe hot side charge pipe to the throttle body coupling, then to the turbo. Do not tighten the clamps yet.
28. Adjust the couplings, ensure that the mounting hole lines up with the mount, then tighten all of the clamps.
29. Secure the aFe charge pipe to the engine with the factory mounting screw (24)

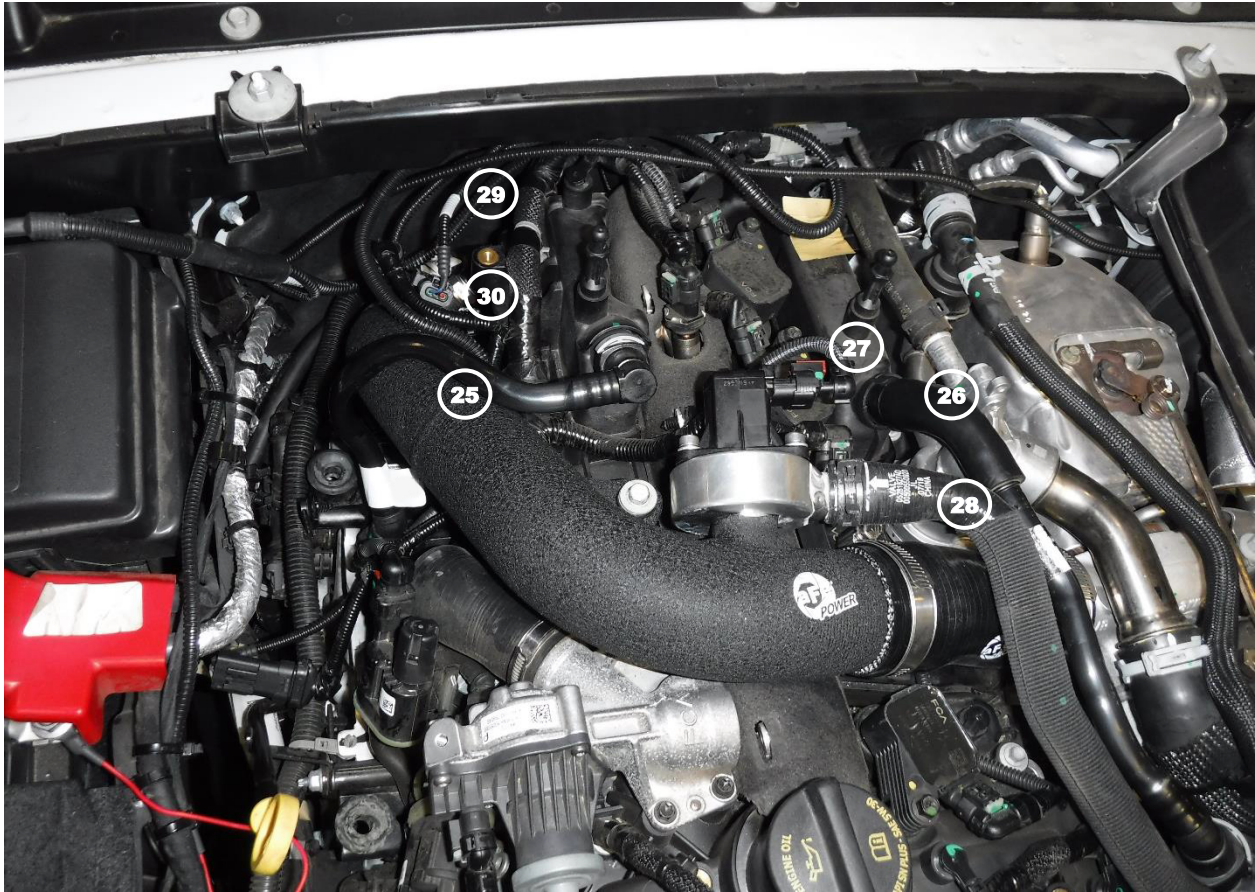

30. Reinstall the vent tube from the intake manifold to the top of the engine, that crosses over the charge pipe, ensure they snap into place and that it is not touching the aFe charge pipe (25)
31. Reconnect the PCV hose to the PCV valve (26)
32. Reconnect the blow off valve actuator connector, then engage the security tab (27)
33. Reconnect the charge air recirculation hose to the aFe charge pipe (28)
34. Reconnect the temperature sensor connector, then engage the security tab (29)
35. Reconnect the MAP sensor connector, then engage the security tab (30)



36. Reinstall the side engine cover into the vehicle (31)

37. Secure the transmission breather hose to the side engine cover (32)

38. Secure the side cover using the factory screws (33)

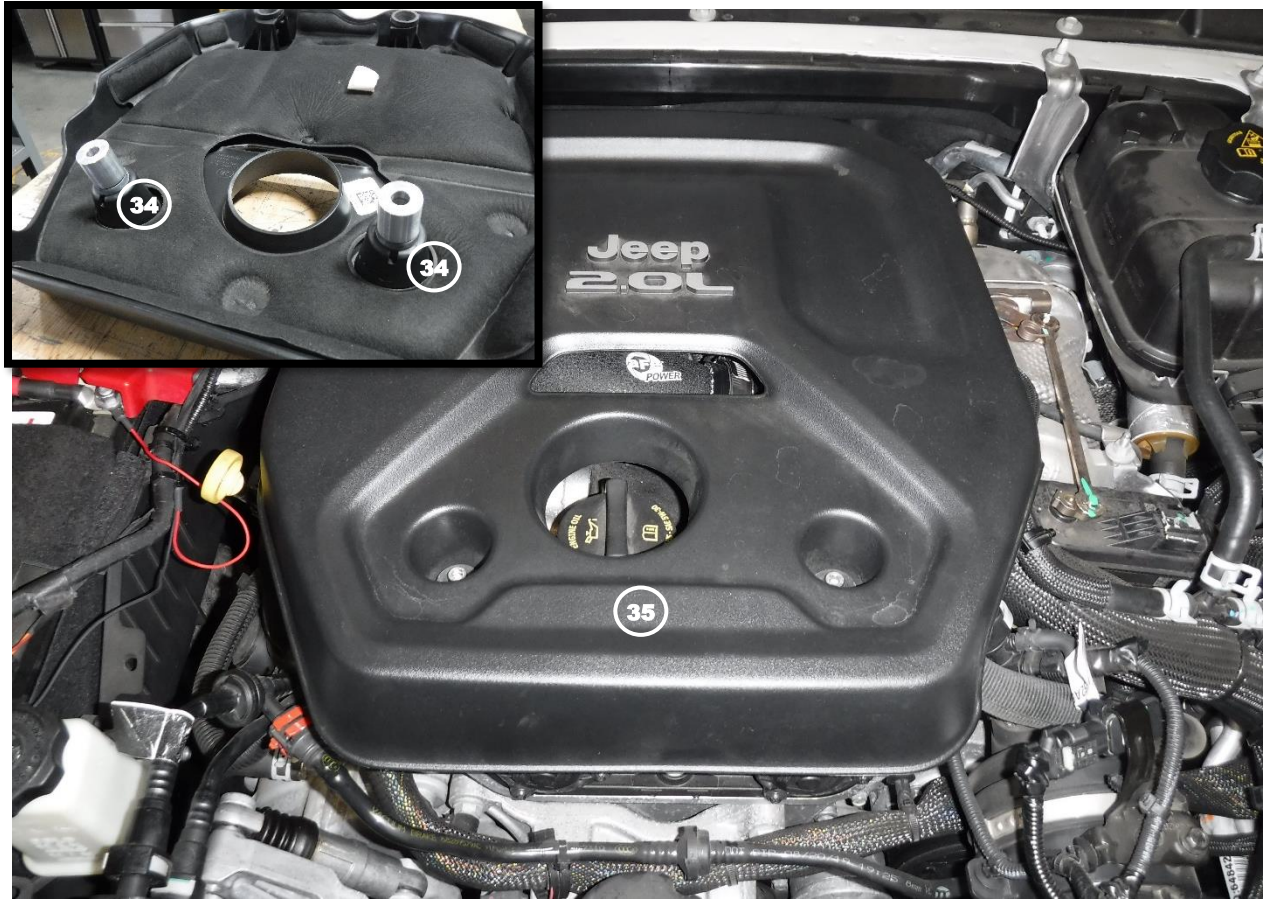

39. Remove the two factory metal insert from the bottom side of the engine cover grommets.
40. Install the two supplied aFe spacers: 22mmOD x 30mmL into the bottom side of the engine cover grommets (34)
41. Reinstall the engine cover (35) onto the vehicle and secure using the supplied M6x1x50mm hex flange screws.
42. Reconnect the negative battery cable.
43. Install is now complete.

Note: Be sure to check all connections after 50-100 miles.