

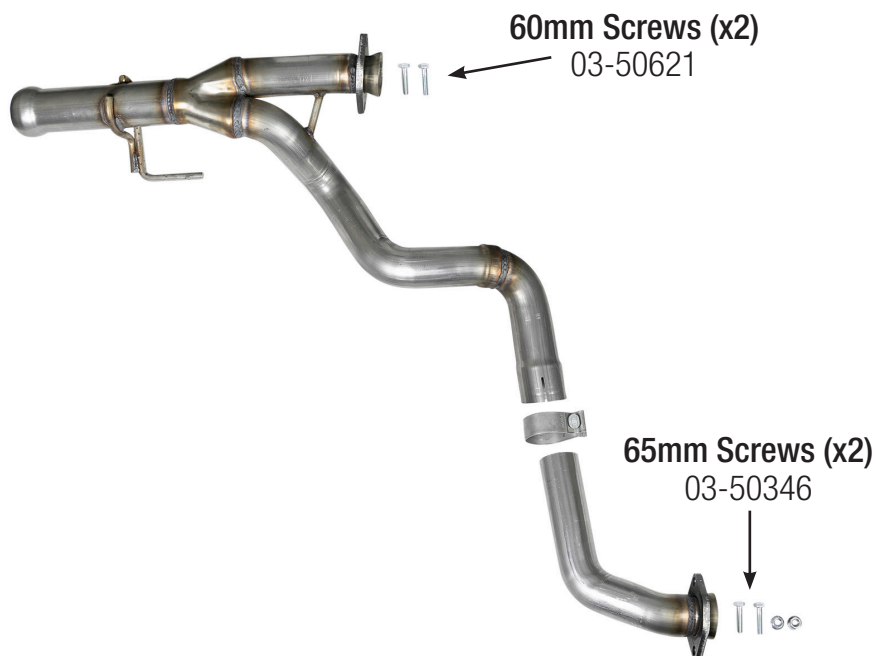

INSTALLATION INSTRUCTIONS

MAKE: Jeep
MODEL: Wrangler (JL)
YEAR: 2018
ENGINE: V6-3.6L (2/4 DR)

Y-Pipe
48-48026



Parts Included:

- (P/N: 05-144528) Right Side Y-Pipe (x1)
- (P/N: 05-144529) Left Side Y-Pipe (x1)

Hardware Included:

- (P/N: 05-41235) 2" Band Clamp (x1)
- (P/N: 03-50621) 60mm Screws (x2)
- (P/N: 03-50189) Nuts (x2)
- (P/N: 03-50346) 65mm Screws (x2)

Caution: aFe recommends professional installation on our products. Allow time for your vehicle to cool down prior to installation. When working on or under your vehicle proceed with caution. Exhaust systems reach high temperatures and may cause serious burns. Wear protective safety equipment; eye goggles and gloves to ensure a safe installation.

- Step 1:** (**Read Instructions prior to installation**) for faster removal and installation of exhaust a trained professional is recommended for this procedure. Secure stock exhaust with jack/stands before removing. Please allow exhaust to cool down! This will prevent any burn injuries
- Step 2:** Remove muffler and remove the stock ball clamp from the y-pipe and mid pipe section.
- Step 3:** Remove the cross member.
- Step 4:** Support the stock y-pipe with stand. Loosen and remove the (x2) bolts on each side down pipes holding the stock y-pipe and remove.
- Step 5:** Slide the supplied (2-1/4") band clamp over the notched section of the driver side aFe Y-Pipe section.
- Step 6:** Slip the passenger and driver side of the aFe Y-Pipe at the slip joint but do not tighten the band clamp.
- Step 7:** Using the supplied bolts (x2), secure the aFe Y-Pipe to the driver side catalytic converters but do not tighten.
- Step 8:** Using the supplied bolts and nut (x2), secure the aFe Y-Pipe to the passenger side catalytic converters but do not tighten.
- Step 9:** Now go back and tighten the all bolts and nut on the aFe Y-Pipe.
- Step 10:** Reinstall the mid pipe using the stock ball clamp.
- Step 11:** Reinstall the muffler section.
- Step 12:** Reinstall the cross member.
- Step 13:** Straighten all exhaust components and begin to tighten down all clamps and bolts nut beginning at the front and ending at the rear.
- Step 14:** Double check all work and ensure everything is tight.
- Step 15:** Start the vehicle and check for any leaks.
- Step 16:** Congratulations your exhaust is now complete.
- Step 17:** Remove vehicle off the jack stands and re-connect negative battery terminal.