

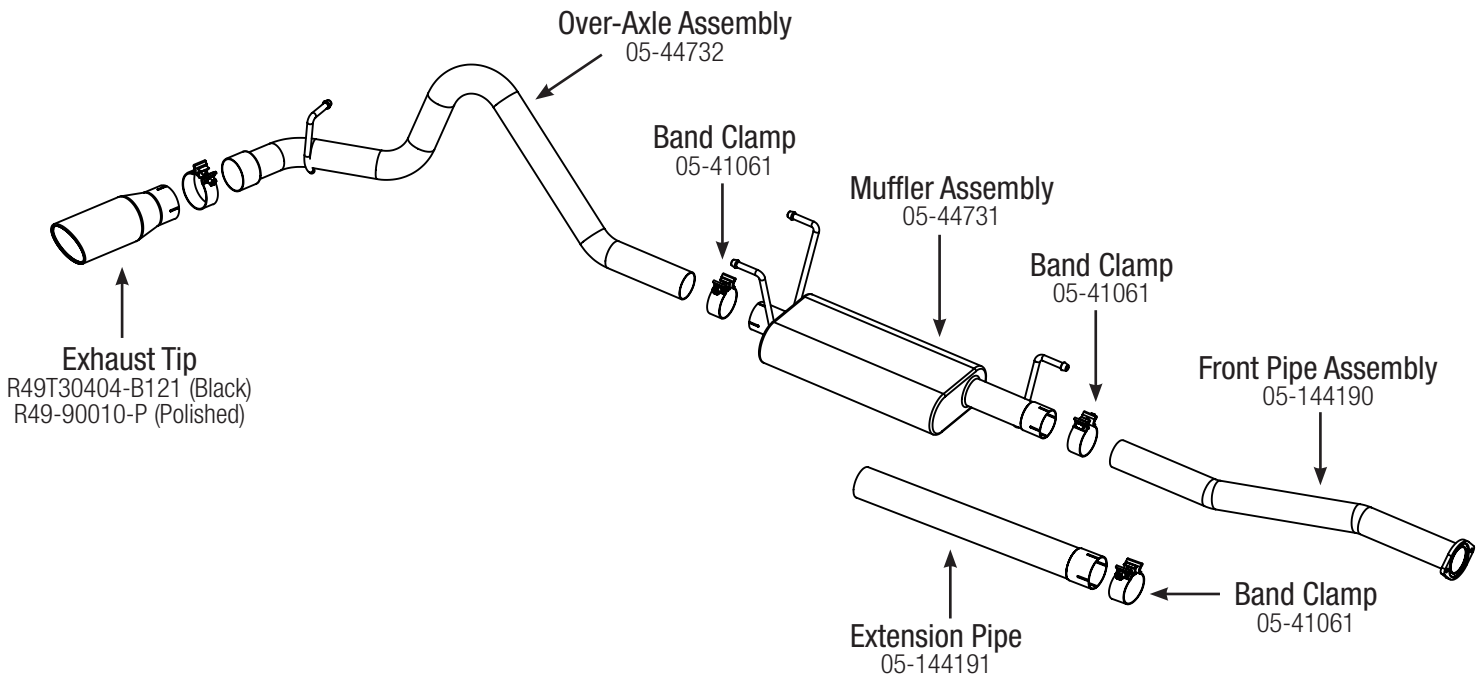

INSTALLATION INSTRUCTIONS

MAKE: Toyota
MODEL: Tacoma
YEAR: 2005 - 2012
ENGINE: L4-2.7L
FITS: CC/SB-LB & EC/LB

Cat-Back Exhaust
49-46031-B (Black Tip)
49-46031-P (Polished Tip)



Caution: aFe recommends professional installation on our products. Allow time for your vehicle to cool down prior to installation. When working on or under your vehicle proceed with caution. Exhaust systems reach high temperatures and may cause serious burns. Wear protective safety equipment; eye goggles and gloves to ensure a safe installation.

- Step 1:** (Read instructions prior to installation.) Remove your stock exhaust up to the catalytic converter from the rear of your vehicle, working your way forward. Take caution not to damage the factory hardware and isolation mounts as they will be reused. (It is recommended to not fully tighten the clamps until the entire system has been installed.)
- Step 2:** For faster installation, spread the pieces of the exhaust alongside of your vehicle according to the diagram shown above.
- Step 3:** Install the front pipe and muffler assembly onto the stock y-pipe using the stock bolts, gaskets, and factory isolation mounts. (Use a jack stand to support the muffler assembly.)
- Step 4:** Using the provided hardware, slide a clamp onto one end of the muffler assembly and proceed to insert the over axle pipe into the muffler assembly.
- Step 5:** Using the provided hardware, slide a clamp onto the tailpipe assembly and proceed to insert the tailpipe into the over-axle assembly.
- Step 6:** Place the tip at desired position, do not fully tighten.
- Step 7:** Adjust and straighten out the exhaust. You can now begin to tighten down your exhaust, beginning at the front flange and working your way back.
- Step 8:** Your installation is now complete. It is recommended to re-tighten all exhaust components after 50 - 100 miles.

Note: aFe recommends that the tailpipe be at least 1/2"-1" away from any body panels to avoid heat related body damage. Tighten and secure.