

# Air Lift 1000™



## Installation Instructions



*GM Midsize SUV*

## **Kit 60856**

For maximum effectiveness and safety, please read these instructions completely before proceeding with installation.

Failure to read these instructions can result in an incorrect installation.

# TABLE OF CONTENTS

<b>Hardware and Tools Lists</b> . . . . .	<b>2</b>
<b>Introduction</b> . . . . .	<b>3</b>
Notation Explanation . . . . .	.3
<b>Installing the System</b> . . . . .	<b>4</b>
Preparing the Vehicle. . . . .	.4
Installing the Air Lift 1000 System. . . . .	.4
<b>Installing the Air Lines</b> . . . . .	<b>6</b>
Complete the Installation . . . . .	.7
<b>Finished Installation</b> . . . . .	<b>8</b>
Installation Checklist . . . . .	.8
Maintenance and Use Guidelines . . . . .	.8

# Hardware and Tools Lists

## HARDWARE LIST

Item	Part#	Description .....	Qty
A	46137	Air spring.....	2
B	09112	Lower protector.....	2
C	20937	Air line .....	15"
D	10466	Zip ties .....	6
E	21230	Valve cap.....	2
F	21233	5/16" Hex nut.....	4
G	21234	Rubber washer.....	2
H	18411	Star washer.....	2
I	18501	M8 Flat washer.....	2
J	21236	Tee fitting.....	1
K	21455	Schrader valve .....	2
L	106385	Air line clamp .....	6

## TOOLS LIST

Description.....	Qty
Pliers, needle nose and regular .....	1
5/16 Drill bit .....	1
Drill .....	1
Hose cutter, razor blade or sharp knife .....	1
Hoist or floor jack .....	1
Safety stands.....	2
Safety glasses .....	1
Air compressor or compressed air source .....	1
Spray bottle with dish soap/water solution.....	1
Tire spoon or blunt instrument .....	1

# Introduction

The purpose of this publication is to assist with the installation and maintenance of the Air Lift 1000 air spring kit.

Air Lift 1000 kits utilize a cylinder-style air bag that provides up to 1,000 pounds (454kg) of load-leveling support when installed into the vehicles coil springs. Each cylinder is rated at a maximum of 35 PSI (2.4BAR).

It is important to read and understand the entire installation guide before beginning installation or performing any maintenance, service or repair.

## NOTATION EXPLANATION

Hazard notations appear in various locations in this publication. Information which is highlighted by one of these notations must be observed to help minimize risk of personal injury or possible improper installation which may render the vehicle unsafe. Notes are used to help emphasize areas of procedural importance and provide helpful suggestions. The following definitions explain the use of these notations as they appear throughout this guide.



INDICATES IMMEDIATE HAZARDS WHICH WILL RESULT IN SEVERE PERSONAL INJURY OR DEATH.



INDICATES HAZARDS OR UNSAFE PRACTICES WHICH COULD RESULT IN SEVERE PERSONAL INJURY OR DEATH.



INDICATES HAZARDS OR UNSAFE PRACTICES WHICH COULD RESULT IN DAMAGE TO THE MACHINE OR MINOR PERSONAL INJURY.

# Installing the System

## PREPARING THE VEHICLE

1. Jack up the rear of the vehicle or raise on a hoist. Support the frame with safety stands (Fig. 1).
2. Lower the suspension or raise the body until the coil springs are completely extended (wheels hanging).

 **CAUTION**

OBSERVE TENSION ON BRAKE LINES. DO NOT STRAIN OR OVEREXTEND.

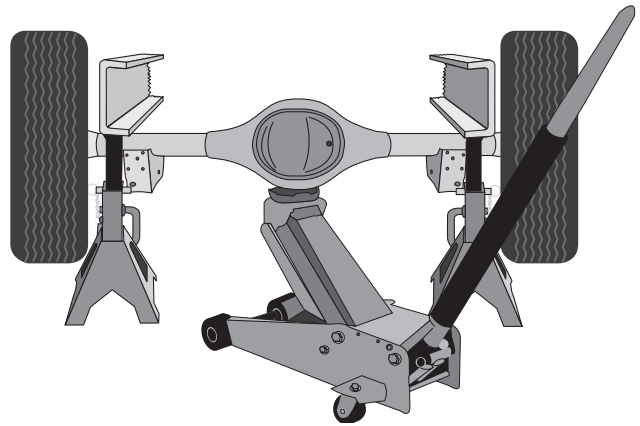

*Fig. 1*

## INSTALLING THE AIR LIFT 1000 SYSTEM

1. Remove the plastic cap from the barbed stem on the end of the air spring (A). Exhaust the air from the air spring by rolling it up towards the barbed stem. Replace the cap on the stem to hold its flat shape (Fig. 2). Fold the air spring into a “hot dog bun shape”.

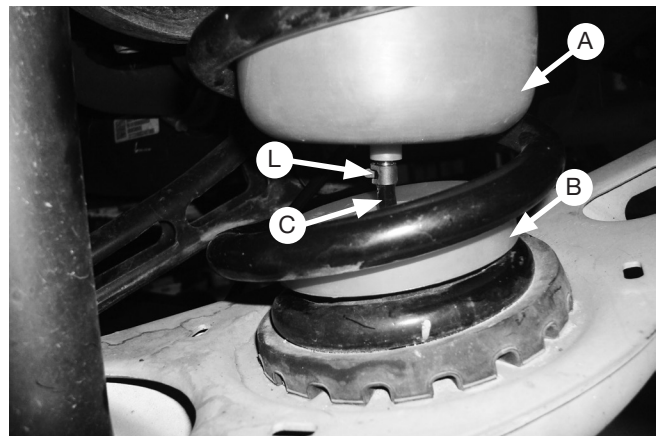

*Fig. 2*

2. Insert the flattened end of the air spring (A) into the top opening in the coil spring, with the stem at the bottom (Fig. 3). Push the spring down into the cylinder by hand or with a blunt instrument such as a spoon-type tire iron.

*Fig. 3*

3. When the air spring (A) is completely in the coil, remove the cap and allow the air spring to assume its “as molded” shape.
4. Push the air spring (A) to the top of the coil spring and insert the lower protector (B) at the bottom between the lower spring seat and the air spring (Fig. 4). Install the air line (C) through the control arm and lower protector, then attach to the air spring per air line installation instructions using air line clamps (L).

*Fig. 4*

5. Route the air line to the center lower control arm pivot and up to the top of the crossmember. For a single fill, add a tee above or route separate air lines to the side away from the exhaust muffler or any heat source (Fig. 5). Secure air line with zip ties (D) supplied.

*Fig. 5*

# Installing the Air Lines

1. A single-path air line installation is recommended for vehicles that typically have even weight distribution (Fig. 6). If weight in the vehicle varies from side to side and unequal pressures are needed to level the load, use a dual-path installation. For dual-path air line installations, eliminate the tee fitting (J) and route separate air lines for both air springs (Fig. 7).

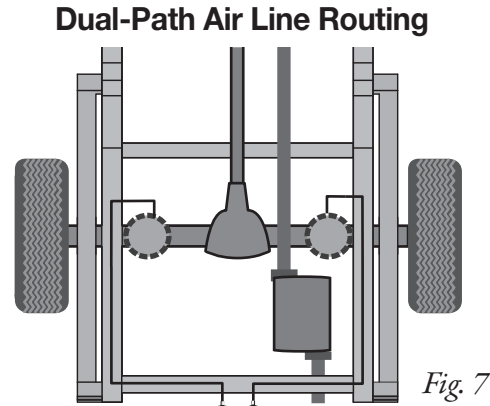
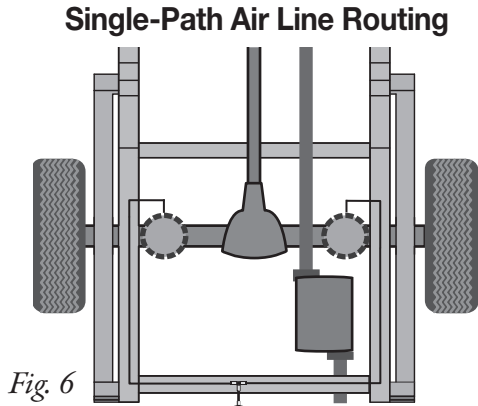

## ⚠ CAUTION

TO PREVENT THE AIR LINE FROM MELTING, MAINTAIN AT LEAST 6" (152MM) FROM THE EXHAUST SYSTEM TO THE AIR LINE.

2. If installing a single-path air line, choose a location for the tee fitting (J) on the back of wheel well or rear bumper. Determine and cut adequate length of air line (C) to reach to the tee from left and right side air springs. Make clean, square cuts with a razor blade or hose cutter (Fig. 8). Do not use scissors or wire cutters.

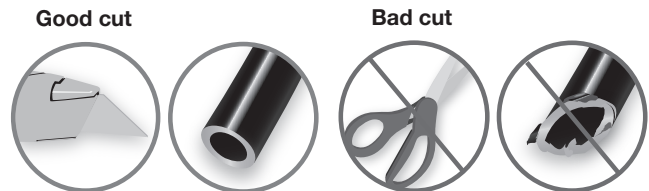

3. Leave sufficient air line slack to prevent any strain on the fitting during axle motions.

4. Use this procedure (Fig. 9) for all air line connections:
  - a. Slide the air line clamp onto the air line.
  - b. Push the air line and air line clamp over the barbed stem so that the air line covers all the barbs.
  - c. Compress the ears on the air line clamp with pliers and slide it forward to fully cover the barbs.

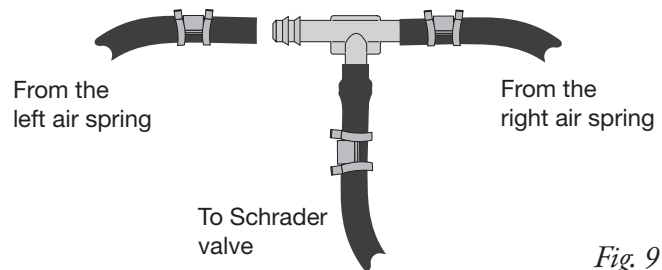

5. Select a location for the Schrader valve (K), ensuring that the valve will be protected and accessible with an air hose (Fig. 10). Drill a 5/16" (8mm) hole, if necessary. Determine and cut adequate length of air line (C) to reach from the tee to the Schrader valve or from the air springs to the valve if using a dual-path installation.

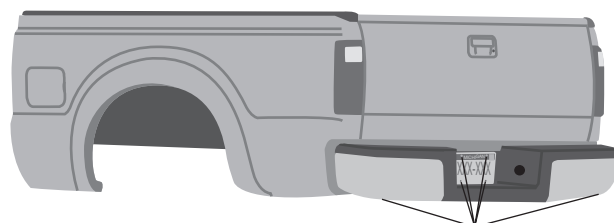

- Drill a 5/16" (8mm) hole for the Schrader valve (K) and mount as shown (Fig. 11). Install the air line on the Schrader valve first. The rubber washer (G) serves as an outside weather seal.

**CAUTION**

DO NOT INFLATE THE AIR SPRINGS BEFORE READING THE MAINTENANCE AND USE GUIDELINES IN THIS INSTALLATION GUIDE AS WELL AS THE USER GUIDE INCLUDED WITH THIS KIT.

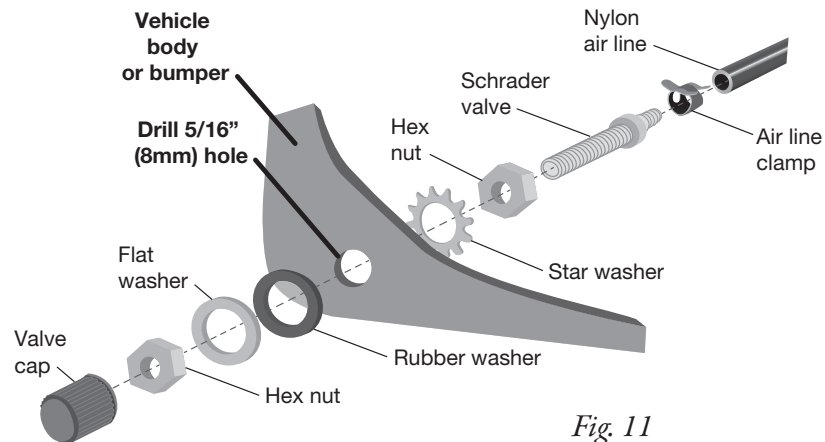

*Fig. 11*

## COMPLETE THE INSTALLATION

- Once the air line has been installed, raise the suspension, or lower the body completely and remove the safety stands (Fig. 12). Inflate the air springs as stated in the next section and check for leaks.

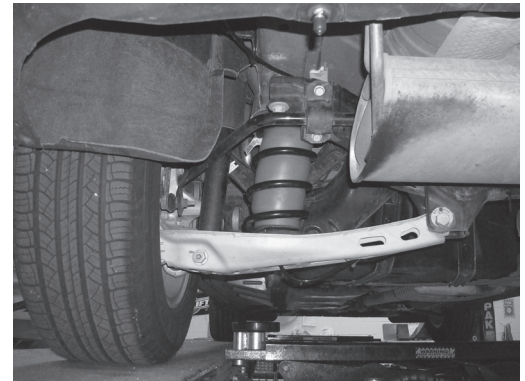

*Fig. 12*

# Finished Installation

## INSTALLATION CHECKLIST

- Clearance test** — Inflate the air springs to 30 PSI (2BAR) and make sure there is at least 1/2" (13mm) clearance from anything that might rub against each air spring. Be sure to check the tire, brakes, frame, shock absorbers and brake cables.
- Leak test before road test** — Inflate the air springs to 30 PSI (2BAR) and check all connections for leaks. All leaks must be eliminated before the vehicle is road tested.
- Heat test** — Be sure there is sufficient clearance from heat sources, at least 6" (152mm) for air springs and air lines. If a heat shield was included in the kit, install it.
- Fastener test** — After 500 miles (800km), recheck all bolts for proper torque.
- Road test** — The vehicle should be road tested after the preceding tests. Inflate the air springs to recommended driving pressures. Drive the vehicle 10 miles (16km) and recheck for clearance, loose fasteners and air leaks.
- Operating instructions** — If professionally installed, the installer should review the operating instructions with the owner. Be sure to provide the owner with all of the paperwork that came with the kit.

## MAINTENANCE AND USE GUIDELINES

1. Check air pressure weekly.
2. Always maintain normal ride height. Never inflate beyond 35 PSI (2.4BAR).
3. If the system develops an air leak, use a soapy water solution to check all air line connections and the inflation valve core before deflating and removing the air spring.

Minimum Recommended Pressure
<b>5 PSI (.34BAR)</b>

Maximum Air Pressure
<b>35 PSI (2.4BAR)</b>

### CAUTION

FOR SAFETY AND TO PREVENT POSSIBLE DAMAGE TO THE VEHICLE, DO NOT EXCEED MAXIMUM GROSS VEHICLE WEIGHT RATING (GVWR) OR PAYLOAD RATING, AS INDICATED BY THE VEHICLE MANUFACTURER.

ALTHOUGH THE AIR SPRINGS ARE RATED AT A MAXIMUM INFLATION PRESSURE OF 35 PSI (2.4BAR), THE AIR PRESSURE ACTUALLY NEEDED IS DEPENDENT ON LOAD AND GROSS VEHICLE WEIGHT RATING.