

Load*LIFTER* **5000**[™] **ULTIMATE** ADJUSTABLE AIR HELPER SPRINGS

TOW AND HAUL WITH SAFETY AND COMFORT[™]



Kit Number
88101

INSTALLATION GUIDE

For maximum effectiveness and safety, please read these instructions completely before proceeding with installation.

Failure to read these instructions can result in an incorrect installation.

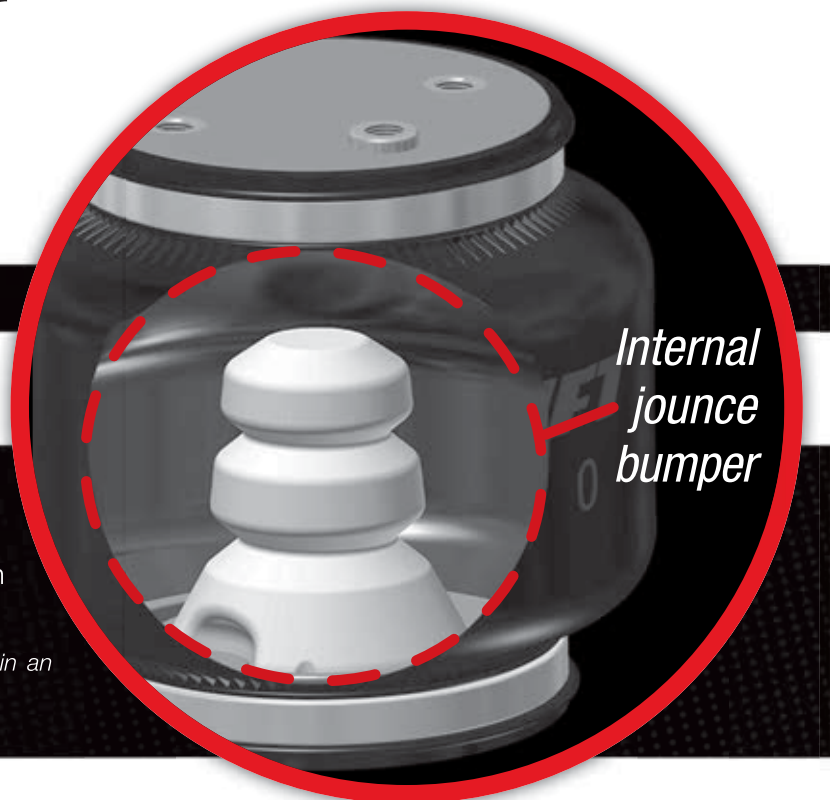

TABLE OF CONTENTS

Introduction	2
Important Safety Notice	2
Notation Explanation	2
Installation Diagram	3
Hardware List	4
Tools List	4
Installing the LoadLifter 5000 Ultimate System	4
Assembling the Air Spring Assembly	4
Attaching the Lower Bracket	5
Attaching the Upper Bracket	5
Installing the Other Air Spring	6
Installing the Air Lines	6
Checking For Leaks	7
Fixing Leaks	7
Before Operating	8
Installation Checklist	8
Post-Installation Checklist	8
Product Use, Maintenance and Servicing	9
Minimum and Maximum Pressure	9
Maintenance Guidelines	9
Troubleshooting Guide	9
Frequently Asked Questions	10
Tuning the Air Pressure	10
Guidelines for Adding Air	11
Choosing the Right On-Board Air Compressor System	12
Warranty and Returns Policy	13
Replacement Information	14
Contact Information	14

Introduction

The purpose of this publication is to assist with the installation, maintenance and troubleshooting of the LoadLifter 5000 Ultimate air spring kit. LoadLifter 5000 Ultimate utilizes sturdy, reinforced, commercial grade single or double, depending on the kit, convolute bellows. The bellows are manufactured like a tire with layers of rubber and cords that control growth. An internal jounce bumper inside the spring absorbs shock and eliminates harsh jarring on rough roads. The internal jounce bumper replaces the factory bumper and allows the air springs to safely be run at zero air pressure. LoadLifter 5000 Ultimate kits are recommended for most ¾ and 1 ton pickups and SUVs with leaf springs and provide up to 5,000 lbs. of load leveling support with air adjustability from 5-100 PSI. The kits are also used in motorhome rear kits and some motorhome fronts where leaf springs are used.

It is important to read and understand the entire installation guide before beginning installation or performing any maintenance, service or repair. The information here includes a hardware list, tool list, step-by-step installation information, maintenance tips, safety information and a troubleshooting guide.

IMPORTANT SAFETY NOTICE

The installation of this kit does not alter the Gross Vehicle Weight Rating (GVWR) or payload of the vehicle. Check your vehicle's owner's manual and do not exceed the maximum load listed for your vehicle.

Gross Vehicle Weight Rating: The maximum allowable weight of the fully loaded vehicle (including passengers and cargo). This number — along with other weight limits, as well as tire, rim size and inflation pressure data — is shown on the vehicle's Safety Compliance Certification Label.

Payload: The combined, maximum allowable weight of cargo and passengers that the vehicle is designed to carry. Payload is GVWR minus the Base Curb Weight.

NOTATION EXPLANATION

Hazard notations appear in various locations in this publication. Information which is highlighted by one of these notations must be observed to help minimize risk of personal injury or possible improper installation which may render the vehicle unsafe. Notes are used to help emphasize areas of procedural importance and provide helpful suggestions. The following definitions explain the use of these notations as they appear throughout this guide.

INDICATES IMMEDIATE HAZARDS WHICH WILL RESULT IN SEVERE PERSONAL INJURY OR DEATH.



INDICATES HAZARDS OR UNSAFE PRACTICES WHICH COULD RESULT IN SEVERE PERSONAL INJURY OR DEATH.



INDICATES HAZARDS OR UNSAFE PRACTICES WHICH COULD RESULT IN DAMAGE TO THE MACHINE OR MINOR PERSONAL INJURY.



NOTE

Indicates a procedure, practice or hint which is important to highlight.

Installation Diagram

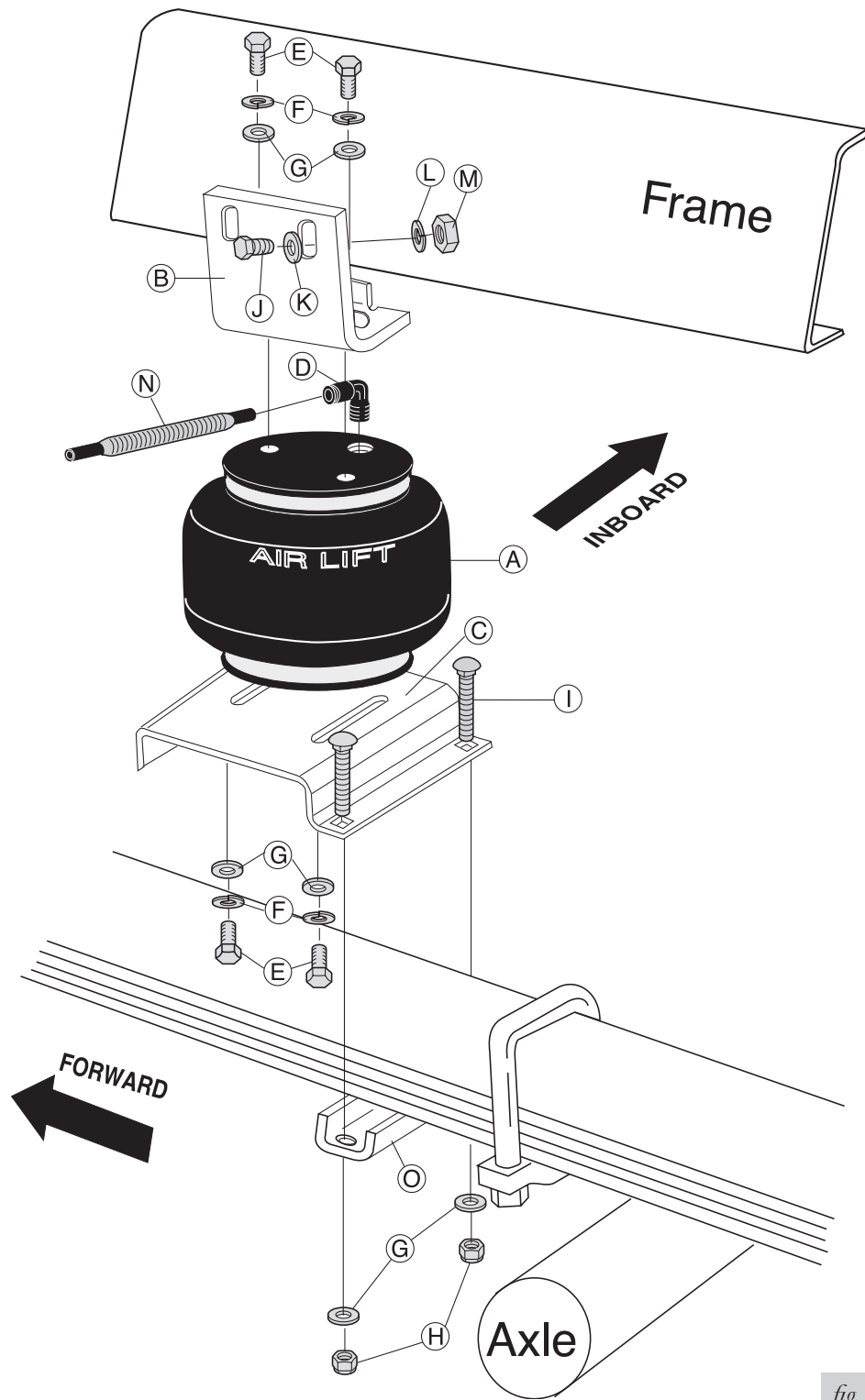

fig. 1

HARDWARE LIST

Item	P/N	Description.....	Qty	Item	P/N	Description.....	Qty
A	58740	Bellow	2	N	09484	Thermal Sleeve.....	2
B	07705	Upper Bracket.....	2	O	01665	Clamp Bar.....	2
C	03006	Lower Bracket.....	2	Air Line Assembly Parts			
D	21848	Elbow Fitting	2	AA	20086	Air Line Assembly.....	1
E	17203	³ / ₈ "-24 x ⁷ / ₈ " Bolt.....	8	BB	10466	Tie Strap*.....	6
F	18427	³ / ₈ " Lock Washer.....	8	CC	21230	Valve Caps*.....	2
G	18444	³ / ₈ " Flat Washer.....	12	DD	18405	5/16" Flat Washer*.....	2
H	18435	³ / ₈ " Nylock Nut.....	4	EE	21234	Rubber Washer*.....	2
I	17142	³ / ₈ "-16 x 3.5" Carriage Bolt.....	4	FF	18411	5/16 Small Star Washer*.....	2
J	17146	¹ / ₂ "-13 x 1.5" Bolt.....	2	GG	21233	5/16" Hex Nut*.....	4
K	18414	¹ / ₂ " Flat Washer.....	2	(* not shown in Figure 1)			
L	18429	¹ / ₂ " Lock Washer.....	2				
M	18431	¹ / ₂ " Hex Nut.....	2				

TOOL LIST

Description.....	Qty
7/16", 9/16" open-end or box wrenches.....	1
7/16" and 9/16" open-end or box wrenches.....	1
Crescent Wrench.....	1
Ratchet with 3/8", 9/16", and 1/2" deep well sockets.....	1
3/8" and 5/16" drill bits (very sharp).....	1
3/8" Nut Driver.....	1
Heavy Duty Drill.....	1
Torque Wrench.....	1
Hose Cutter, Razor Blade, or Sharp Knife.....	1
Hoist or Floor Jacks.....	1
Safety Stands.....	1
Safety Glasses.....	1
Air Compressor, or Compressed Air Source.....	1
Spray Bottle with Dish Soap/Water Solution.....	1

Installing the LoadLifter 5000 Ultimate System

NOTE

IMPORTANT: Your vehicle may be equipped with a rear brake proportioning valve. Any type of load assist product could affect brake performance. It is recommended that you check with your dealer before installing this type of product. If your vehicle DOES NOT have a rear brake proportioning valve or is equipped with an anti-lock type brake system, installation of a load assist product will have NO EFFECT ON BRAKE SYSTEM .



COMPRESSED AIR CAN CAUSE INJURY AND DAMAGE TO THE VEHICLE AND PARTS IF IT IS NOT HANDLED PROPERLY. FOR YOUR SAFETY, DO NOT TRY TO INFLATE THE AIR SPRINGS UNTIL THEY HAVE BEEN PROPERLY SECURED TO THE VEHICLE.

ASSEMBLING THE AIR SPRING ASSEMBLY

Refer to Figure 1.

1. Consult your User's Manual to determine the normal ride height of your vehicle.

2. Loosely attach the 90° elbow fitting (D) to the top of the air spring. Tighten finger tight plus 1 and 1/2 turns. Be careful to tighten on the metal hex nut only. **DO NOT OVERTIGHTEN.**
3. Loosely attach the upper bracket (B) to the air spring (A) with two 3/8" bolts (E), two 3/8" lock washers (F), and two 3/8" flat washers (G).
4. Attach the air spring to the lower bracket (C) with two 3/8" bolts (E), two 3/8" lock washers (F), and two 3/8" flat washers (G). Leave loose at this time.

ATTACHING THE LOWER BRACKET

Refer to Figure 1.

1. Insert two 3/8" carriage bolts (I) through the lower bracket. Attach the lower bracket to the leaf spring forward of the axle by securing the carriage bolts to a clamp bar (O) underneath the leaf spring.
2. Secure the carriage bolts with two 3/8" flat washers (G) and 3/8" nyloc nuts (H). Tighten all nuts to 20 ft.lbs.

ATTACHING THE UPPER BRACKET

Refer to Figure 1.

1. Position the upper bracket (B) on the frame rail so that it is aligned front-to-rear and inboard-to-outboard. Upper and lower brackets are slotted for adjustment.

NOTE

The short end of the upper bracket must be positioned so that it is touching the underside of the frame rail (Figure 2).

2. Put the upper bracket into position on the frame rail and drill one 1/2" hole in the side of the frame rail (Figure 3).

CAUTION

DO NOT DRILL HOLES IN THE FRAME BEFORE CHECKING FOR HYDRAULIC LINES, GAS LINES AND/OR ELECTRICAL WIRES THAT MAY HAVE TO BE MOVED OUT OF THE WAY TO EITHER SIDE OF THE FRAME.

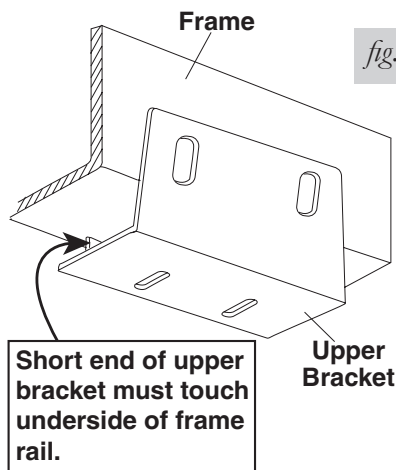

fig. 2

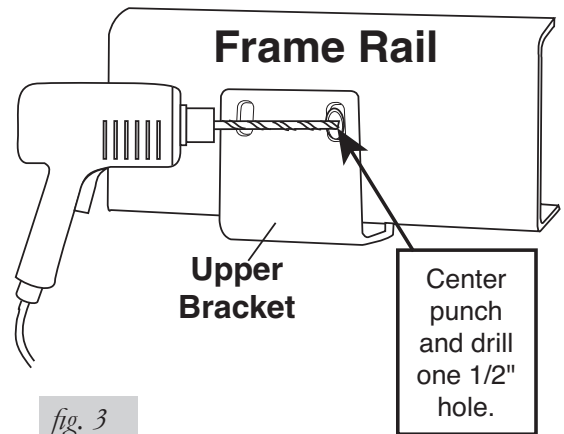

fig. 3

3. Recheck the alignment. Using the slots in the lower bracket, align the air spring so that it is square, vertically and horizontally, to the upper bracket.
4. Tighten the air spring mounting bolts to 20 ft.lbs. Attach the upper bracket using one 1/2"-13 x 1.5" bolt (J), one 1/2" flat washer (K), one 1/2" lock washer (L), and one 1/2" hex nut (M). Only one bolt is required to secure the bracket to the frame.

INSTALLING OTHER AIR SPRING

1. Installation for one air spring is now complete. Continue by repeating the steps in **Assembling the Air Assembly, Attaching the Lower Bracket and Attaching the Upper Bracket** for the other side.
2. Proceed to **Installing the Air Lines** when the second air spring is installed.

INSTALLING THE AIR LINES

1. Choose a convenient location for mounting the inflation valves. Popular locations for the inflation valve are in the wheel well flanges, in the stowage area, or under the body flange.

NOTE

What ever the chosen location is, make sure there is enough clearance around the inflation valves for an air chuck.

2. Drill a 5/16" hole to install the inflation valves.
3. Cut the air line assembly (AA) in two equal lengths.

CAUTION

WHEN CUTTING OR TRIMMING THE AIR LINE, USE A HOSE CUTTER, A RAZOR BLADE, OR A SHARP KNIFE. A CLEAN, SQUARE CUT WILL ENSURE AGAINST LEAKS. DO NOT USE WIRE CUTTERS OR SCISSORS TO CUT THE AIR LINE. THESE TOOLS MAY FLATTEN OR CRIMP THE AIR LINE, WHICH CAUSES LEAKAGE AROUND THE O-RING SEAL INSIDE THE ELBOW FITTING.

4. Place a 5/16" nut (GG) and a star washer (FF) on the air valve. Leave enough of the valve in front of the nut to extend through the hole and have room for the rubber washer (EE), flat washer (DD), and 5/16" nut (GG) and cap (CC). There should be approximately 1/2" of the valve exposed after installation to easily apply a pressure gauge or an air chuck (Figure 4).
5. Push the inflation valve through the hole and use the rubber washer (EE), flat washer (DD), and another 5/16" nut (GG) to secure it in place. Tighten the nuts to secure the assembly in place (Figure 4).

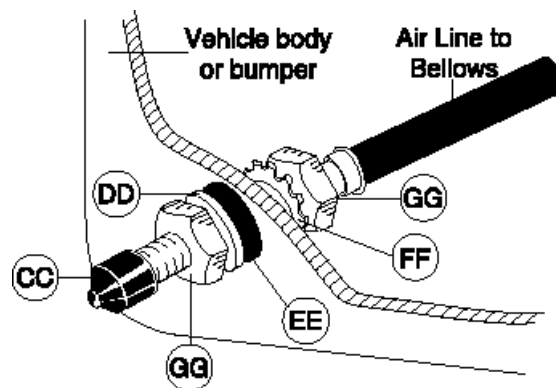

fig. 4

6. Route the air line along the frame to the air fitting on the air spring (Figure 5). Keep at least 6" of clearance between the air line and heat sources, such as the exhaust pipes, muffler, or catalytic converter. Avoid sharp bends and edges. Use the plastic tie straps (BB) to secure the air line to fixed, non-moving points along the chassis. Be sure that

the tie straps are tight, but do not pinch the air line. Leave at least 2” of slack to allow for any movement that might pull on the air line.

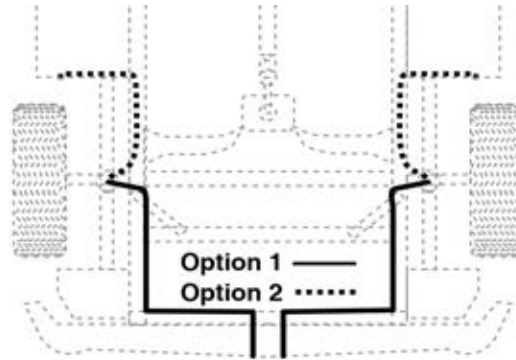

fig. 5

7. On the exhaust side only, place the provided thermal sleeve (P) on the air line near the exhaust.
8. Cut off air line, leaving approximately 12” of extra air line. A clean square cut will ensure against leaks. Insert the air line into the push-to-connect air fitting. Simply push the air line into the 90° swivel fitting until it bottoms out (9/16” of air line should be in the fitting).

CHECKING FOR LEAKS

1. Inflate the air spring to 60 p.s.i. and spray all connections and the inflation valves with a solution of 1/5 liquid dish soap and 4/5 water to check for leaks. Leaks will be spotted easily by looking for bubbles in the soapy water.
2. After the test, deflate the springs to the minimum pressure required to restore the Normal Ride Height, but not less than 20 p.s.i.

NOTE

IMPORTANT: Check the air pressure again after 24 hours. A 2 to 4 p.s.i. loss after initial installation is normal. Retest for leaks if the loss is more than 5 lbs.

FIXING LEAKS

1. If there is a problem with the swivel fitting, then:
 - a. Check the air line connection by deflating the spring and removing the line by pulling the collar against the fitting and pulling firmly on the air line. Trim 1” off the end of the air line. Be sure the cut is clean and square. Reinsert the air line into the push-to-connect fitting.
 - b. Check the threaded connection by tightening the swivel fitting another 1/2 turn. If it still leaks, deflate the air spring, remove the fitting, and re-coat the threads with thread sealant. Reinstall by hand tightening as much as possible, then use a wrench for an additional two turns.
2. If there is a problem with the inflation valve, then:
 - a. Check the valve core by tightening it with a valve core tool.
 - b. Check the air line connection by removing the air line from the barbed type fitting.

CAUTION

CAUTION: DO NOT CUT IT OFF. AS THIS WILL USUALLY NICK THE BARB AND RENDER THE FITTING USELESS. CUT AIR LINE OFF A FEW INCHES IN FRONT OF THE FITTING AND USE A PAIR OF PLIERS OR VISE-GRIPS TO PULL/TWIST THE AIR LINE OFF THE FITTING.

Before Operating

INSTALLATION CHECKLIST (To be completed by installer)

- Clearance test — Inflate the air springs to 60 PSI and ensure there is at least ½” clearance around each bellow, away from anything that might rub against them. Be sure to check the tire, brake drum, frame, shock absorbers and brake cables.
- Leak test before road test — Inflate the air springs to 60 PSI, check all connections for leaks with a soapy water solution. See page 12 for tips on how to spot leaks. All leaks must be eliminated before the vehicle is road tested.
- Fastener test — Recheck all bolts for proper torque. Axle clamp bar carriage bolt lock nuts should be torqued to 16 ft/lbs. Re-torque after 100 miles.
- Road test — The vehicle should be road tested after the preceding tests. Inflate the air springs to 25 PSI (50 PSI if the vehicle is loaded). Drive the vehicle 10 miles and recheck for clearance, loose fasteners and air leaks.
- Operating instructions — If professionally installed, the installer should review the Product Use, Maintenance and Servicing section on page 14 with the owner. Be sure to provide the owner with all of the paperwork which came with the kit.

Technician's Signature _____

Date _____

POST-INSTALLATION CHECKLIST

- Overnight leak down test — Recheck air pressure after the vehicle has been used for 24 hours. If the pressure has dropped more than 5 PSI, then there is a leak that must be fixed. Either fix the leak yourself or return to the installer for service.
- Air pressure requirements — Regardless of load, the air pressure should always be adjusted to maintain ride height at all times.
- Thirty day or 500 mile test — Recheck the air spring system after 30 days or 500 miles, whichever comes first. If any part shows signs of rubbing or abrasion, the source should be identified and moved, if possible. If it is not possible to relocate the cause of the abrasion, the air spring may need to be remounted. If professionally installed, the installer should be consulted. Check all fasteners for tightness.

Product Use, Maintenance and Servicing

Minimum Recommended Pressure	Maximum Air Pressure
40 PSI	100 PSI

MAINTENANCE GUIDELINES

NOTE

By following the steps below, vehicle owners will obtain the longest life and best results from their air springs.

1. Check the air pressure weekly.
2. Always maintain normal ride height. Never inflate beyond 100 PSI.
3. If you develop an air leak in the system, use a soapy water solution (1/5 liquid dish soap and 4/5 water) to check all air line connections and the inflation valve core before deflating and removing the air spring.

CAUTION

FOR YOUR SAFETY AND TO PREVENT POSSIBLE DAMAGE TO YOUR VEHICLE, DO NOT EXCEED MAXIMUM GROSS VEHICLE WEIGHT RATING (GVWR), AS INDICATED BY THE VEHICLE MANUFACTURER. ALTHOUGH YOUR AIR SPRINGS ARE RATED AT A MAXIMUM INFLATION PRESSURE OF 100 P.S.I., THE AIR PRESSURE ACTUALLY NEEDED IS DEPENDANT ON YOUR LOAD AND GVWR.

4. Loaded vehicles require at least 25 PSI or more. A “loaded vehicle” refers to a vehicle with a heavy bed load, a trailer, or both. As discussed above, never exceed GVWR, regardless of air spring, air pressure, or other load assist. The springs in this kit will support approximately 40 lbs. of load (combined on both springs) for each 1 PSI of pressure. The required air pressure will vary depending on the state of the original suspension. Operating the vehicle below the minimum air spring pressure will void the Air Lift warranty.
5. When increasing load, always adjust the air pressure to maintain the normal ride height. Increase or decrease pressure from the system as necessary to attain normal ride height for optimal ride and handling. Remember that loads carried behind the axle (including tongue loads) require more leveling force (pressure) than those carried directly over the axle.
6. Always add air to springs in small quantities, checking the pressure frequently.
7. Should it become necessary to raise the vehicle by the frame, make sure the system is at minimum pressure (40 PSI) to reduce the tension on the suspension/brake components. Use of on board leveling systems do not require deflation or disconnection.
8. Periodically check the air spring system fasteners for tightness. Also, check the air springs for any signs of rubbing. Realign if necessary.
9. On occasion, give the air springs a hard spray with a garden hose in order to remove mud, sand, gravel or other abrasive debris.

TROUBLESHOOTING GUIDE

1. Leak test the air line connections, the threaded connection into the air spring, and all fittings in the control system.
2. Inspect the air lines to be sure none are pinched. Tie straps may be too tight. Loosen or replace the strap and replace leaking components.
3. Inspect the air line for holes and cracks. Replace as needed.
4. Look for a kink or fold in the air line. Reroute as needed.

FREQUENTLY ASKED QUESTIONS

Q. Will installing air springs increase the weight ratings of a vehicle?

No. Adding air springs will not change the weight ratings (GAWR, GCWR and/or GVWR) of a vehicle. Exceeding the GVWR is dangerous and voids the Air Lift warranty.

Q. Is it necessary to keep air in the air springs at all times and how much pressure will they need?

For LoadLifter 5000 Ultimate, the recommended minimum air pressure is 5 PSI, but it can safely be run at zero air pressure.

Q. Is it necessary to add a compressor system to the air springs?

No. Air pressure can be adjusted with any type of compressor as long as it can produce sufficient pressure to service the springs. Even a bicycle tire pump can be used, but it's a lot of work.

Q. How long should air springs last?

If the air springs are properly installed and maintained they can last indefinitely.

Q. Will raising the vehicle on a hoist for service work damage the air springs?

No. The vehicle can be lifted on a hoist for short-term service work such as tire rotation or oil changes. However, if the vehicle will be on the hoist for a prolonged period of time, support the axle with jack stands in order to take the tension off of the air springs.

TUNING THE AIR PRESSURE

Pressure determination comes down to three things — level vehicle, ride comfort, and stability.

1. Level vehicle

If the vehicle's headlights are shining into the trees or the vehicle is leaning to one side, then it is not level (fig. 2.1). Raise the air pressure to correct either of these problems and level the vehicle.

2. Ride comfort

If the vehicle has a rough or harsh ride it may be due to either too much pressure or not enough (fig. 2.2). Try different pressures to determine the best ride comfort.

3. Stability

Stability translates into safety and should be the priority, meaning the driver may need to sacrifice a perfectly level and comfortable ride. Stability issues include roll control, bounce, dive during braking and sponginess (fig. 2.3). Tuning out these problems usually requires an increase in pressure.



Bad headlight aim *fig. 2.1*



Rough ride *fig. 2.2*

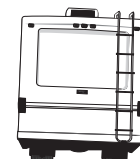

Sway and body roll *fig. 2.3*

GUIDELINES FOR ADDING AIR

1. Start with the vehicle level or slightly above.
2. When in doubt, always add air.
3. If the front of the vehicle dives while braking, increase the pressure in the front air bags, if equipped.
4. If it is ever suspected that the air bags have bottomed out, increase the pressure (fig. 2.4).
5. Adjust the pressure up and down to find the best ride.
6. If the vehicle rocks and rolls, adjust the air pressure to reduce movement.
7. It may be necessary to maintain different pressures on each side of the vehicle. Loads such as water, fuel, and appliances will cause the vehicle to be heavier on one side (fig. 2.5). As much as a 50 PSI difference is not uncommon.



Bottoming out

fig. 2.4

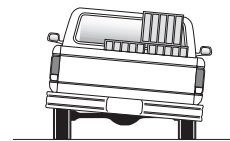

Unlevel

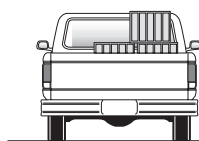

Level

fig. 2.5

Choosing the Right On-Board Air Compressor System

60 DAY NO QUESTIONS ASKED, MONEY-BACK GUARANTEE

TWO YEAR COMPRESSOR SYSTEM WARRANTY

Add an on-board air compressor system to inflate and deflate your air springs with the touch of a button — from inside or outside of the vehicle.

- For convenient, on-the-go control of your air springs, add an Air Lift on-board air compressor system.
- Air Lift on-board air compressor systems eliminate the search for gas stations that have a working compressor, saving you time, energy and money.
- All systems include a compressor, controller and all parts needed for easy installation.

1. Choose single or dual path inflation (see illustrations at right)

2. Choose wireless or analog control

- **Wireless:** Control your air springs from inside or outside the vehicle. Easiest installation - no wires to the cab.
- **Analog:** In-cab control of your air springs. Economically priced.

3. Choose heavy or standard duty compressor

- **Standard duty:** A standard duty compressor will work well for most customers who use their system on an intermittent basis.
- **Heavy duty:** For daily use, consider the heavy duty compressor - it inflates faster and more quietly than the standard compressor.

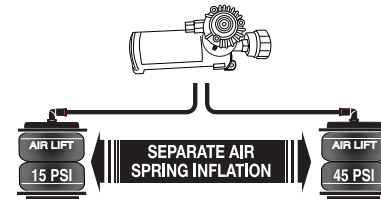

Dual path systems Air springs are controlled separately to allow for different air pressure from side-to-side. Perfect for uneven or top-heavy loads.

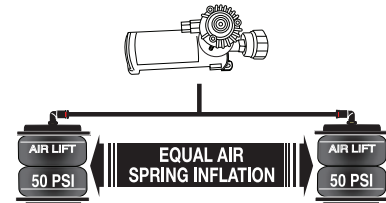

Single path systems Two springs will inflate at the same time. Good for loads that are evenly distributed from left-to-right or front-to-back.

W I R E L E S S

A N A L O G

DUAL PATH

WirelessAIR™

OUR PREMIUM SYSTEM!

- Easy installation
- Includes heavy duty compressor



P/N 72000

SINGLE PATH

WirelessONE™

- Easy installation
- Includes standard duty compressor



P/N 25870

LoadCONTROLLER™

Dual

Compact, economically priced control.



P/N Standard Duty Compressor 25850; P/N Heavy Duty Compressor 25854

LoadCONTROLLER™

Single

Compact, economically priced control.



P/N Standard Duty Compressor 25852; P/N Heavy Duty Compressor 25856