

# **Load****LIFTER** 5000™

## **ULTIMATE**

ADJUSTABLE AIR HELPER SPRINGS

TOW AND HAUL WITH SAFETY AND COMFORT™



Kit Number  
**88237**

### INSTALLATION GUIDE

For maximum effectiveness and safety, please read these instructions completely before proceeding with installation.

*Failure to read these instructions can result in an incorrect installation.*

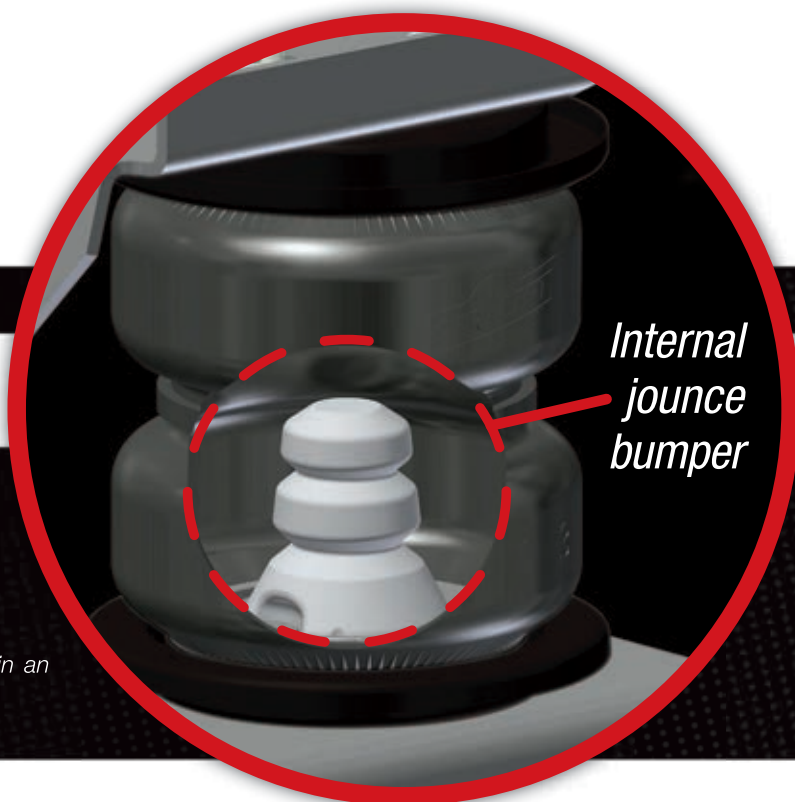

# TABLE OF CONTENTS

<b>Introduction</b> .....	<b>2</b>
Important Safety Notice .....	2
Notation Explanation .....	2
<b>Installation Diagram</b> .....	<b>3</b>
Hardware List .....	4
<b>Installing the LoadLifter 5000 Ultimate System</b> .....	<b>4</b>
Getting Started .....	4
Attaching the Upper Bracket .....	5
Attaching the Lower Bracket .....	5
Installing the Spring Assembly .....	5
Adjusting Your Kit .....	6
Installing the Air Lines .....	7
Checking For Leaks .....	8
Fixing Leaks .....	9
<b>Before Operating</b> .....	<b>10</b>
Installation Checklist .....	10
Post-Installation Checklist .....	10
<b>Product Use, Maintenance and Servicing</b> .....	<b>11</b>
Minimum and Maximum Pressure .....	11
Maintenance Guidelines .....	11
Troubleshooting Guide .....	11
Frequently Asked Questions .....	12
Tuning the Air Pressure .....	12
Guidelines for Adding Air .....	13
<b>Choosing the Right On-Board Air Compressor System</b> .....	<b>14</b>
<b>Warranty and Returns Policy</b> .....	<b>15</b>
<b>Replacement Information</b> .....	<b>16</b>
<b>Contact Information</b> .....	<b>16</b>

# Introduction

The purpose of this publication is to assist with the installation, maintenance and troubleshooting of the LoadLifter 5000 Ultimate air spring kit. LoadLifter 5000 Ultimate utilizes sturdy, reinforced, commercial grade single or double, depending on the kit, convolute bellows. The bellows are manufactured like a tire with layers of rubber and cords that control growth. An internal jounce bumper inside the spring absorbs shock and eliminates harsh jarring on rough roads. The internal jounce bumper replaces the factory bumper and allows the air springs to safely be run at zero air pressure. LoadLifter 5000 Ultimate kits are recommended for most ¾ and 1 ton pickups and SUVs with leaf springs and provide up to 5,000 lbs. of load leveling support with air adjustability from 5-100 PSI. The kits are also used in motorhome rear kits and some motorhome fronts where leaf springs are used.

It is important to read and understand the entire installation guide before beginning installation or performing any maintenance, service or repair. The information here includes a hardware list, tool list, step-by-step installation information, maintenance tips, safety information and a troubleshooting guide.

## IMPORTANT SAFETY NOTICE

The installation of this kit does not alter the Gross Vehicle Weight Rating (GVWR) or payload of the vehicle. Check your vehicle's owner's manual and do not exceed the maximum load listed for your vehicle.

**Gross Vehicle Weight Rating:** The maximum allowable weight of the fully loaded vehicle (including passengers and cargo). This number — along with other weight limits, as well as tire, rim size and inflation pressure data — is shown on the vehicle's Safety Compliance Certification Label.

**Payload:** The combined, maximum allowable weight of cargo and passengers that the vehicle is designed to carry. Payload is GVWR minus the Base Curb Weight.

## NOTATION EXPLANATION

Hazard notations appear in various locations in this publication. Information which is highlighted by one of these notations must be observed to help minimize risk of personal injury or possible improper installation which may render the vehicle unsafe. Notes are used to help emphasize areas of procedural importance and provide helpful suggestions. The following definitions explain the use of these notations as they appear throughout this guide.

INDICATES IMMEDIATE HAZARDS WHICH WILL RESULT IN SEVERE PERSONAL INJURY OR DEATH.

INDICATES HAZARDS OR UNSAFE PRACTICES WHICH COULD RESULT IN SEVERE PERSONAL INJURY OR DEATH.

INDICATES HAZARDS OR UNSAFE PRACTICES WHICH COULD RESULT IN DAMAGE TO THE MACHINE OR MINOR PERSONAL INJURY.



---

## NOTE

*Indicates a procedure, practice or hint which is important to highlight.*

---

# Installation Diagram

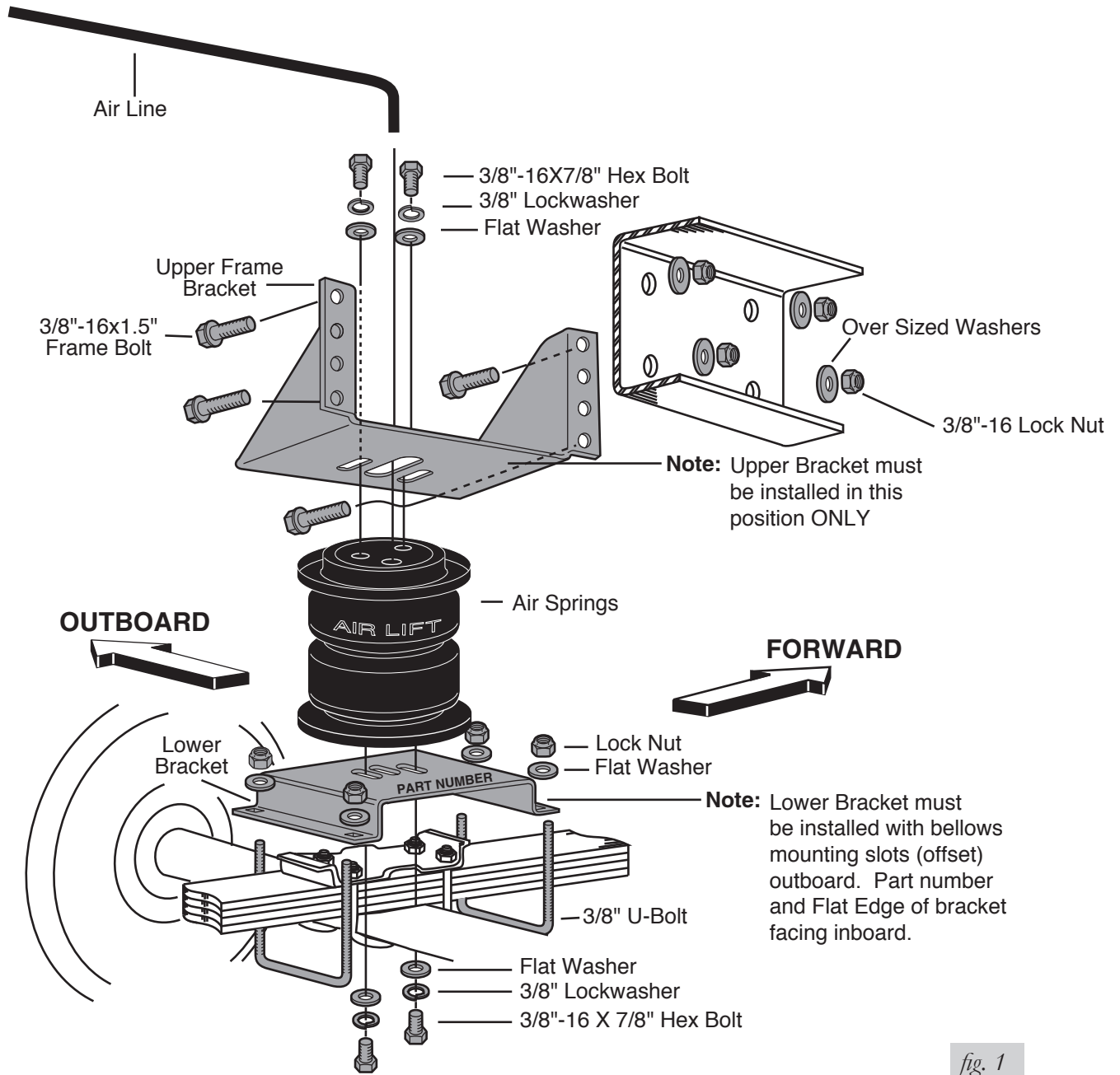

fig. 1

## HARDWARE LIST

Item	Part No.	Description.....	Quantity	<i>Air Line Assembly Parts</i>		
A	03102	Lower Bracket .....	2	Item	Part No. Description..... Quantity	
B	07130	Upper Bracket .....	2	AA	20086 Air Line Assembly..... 1	
C	58496	Air Spring.....	2	BB	10466 Tie Strap..... 6	
D	11967	Roll Plate .....	4	CC	21230 Valve Caps..... 2	
E	10583	4.5" U-Bolt .....	4	DD	18405 5/16" Flat Washer..... 2	
F	17159	3/8" x 1.5" WHFB.....	8	EE	21234 Rubber Washer .....	2
G	18435	Nyloc Nut.....	16	FF	18411 Small Star Washer .....	2
H	18444	3/8" Flat Washer.....	24	GG	21233 5/16" Hex Nut .....	4
I	18447	3/8" Large Flat Washer.....	8			
J	21837	Swivel Head Elbow.....	2			
K	17203	3/8" x 7/8" HHCS.....	8			
L	18427	3/8" Lock Washer .....	8			

# Installing the LoadLifter 5000 Ultimate System

### CAUTION

THE AIR LINE MUST BE INSERTED INTO THE AIR FITTING OR THE AIR FITTING MUST BE COVERED BEFORE DRILLING HOLES TO PREVENT ANY DEBRIS OR METAL SHAVINGS FROM CONTAMINATING THE AIR FITTING.

## GETTING STARTED

1. Raise the vehicle, remove the wheels, and obtain normal ride height (Figures 2 and 3).

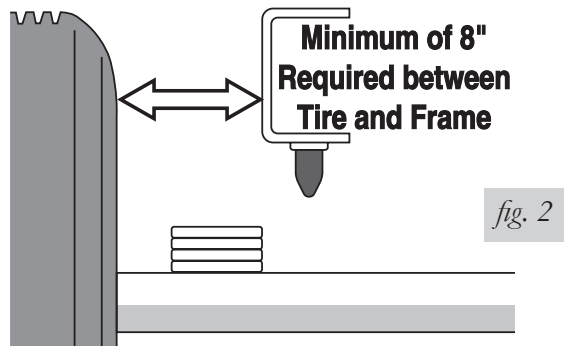

fig. 2

**NORMAL RIDE HEIGHT:** *Normal ride height (no load) is defined as the distance between the bottom edge of the wheel-well to the center point of the hub with the vehicle in an “as delivered condition” (without a load, i.e. tool box, camper, etc.). Measurements should be taken before beginning the installation. The distance from the bottom edge of the wheel well to the center point of the hub should be recorded. All Air Lift kits are designed to be installed and operated at normal ride height.*

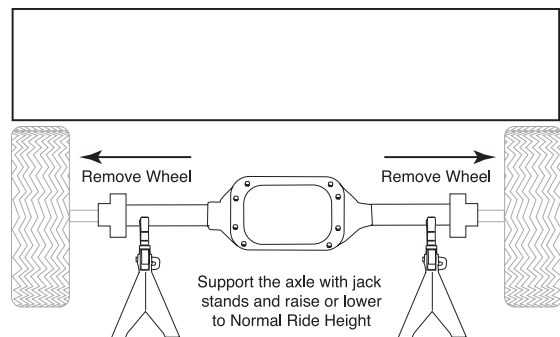
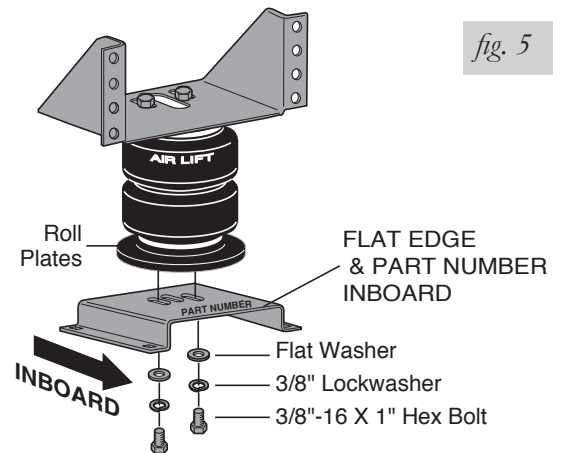
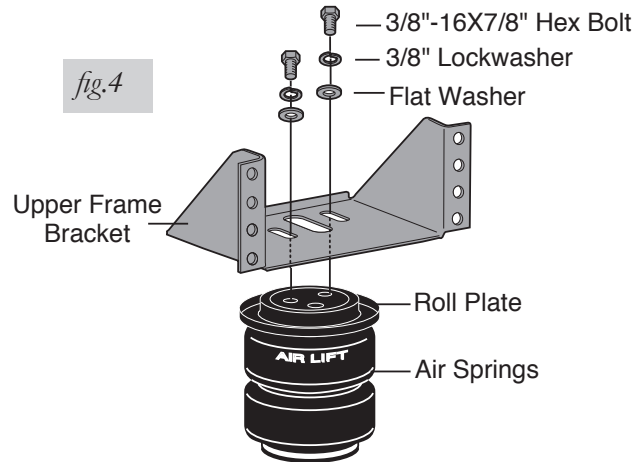

fig. 3

## ATTACHING THE UPPER BRACKET

1. Set a roll plate on both ends of the air spring. The radiused (rounded) edge of the roll plate will be towards the air spring so that the air spring is seated in both roll plates (Figures 1,4 and 5).
2. Align the holes in the roll plate with the holes in the air spring and loosely attach the upper bracket with the “legs up” using two 3/8”-16x7/8” bolts, lock washers, and flat washers (Figure 4). The upper bracket must be installed in this position.



## ATTACHING THE LOWER BRACKET

1. Make sure that the holes in the air spring, roll plate and lower bracket are properly aligned and that the flat edge of the lower bracket is facing inboard.
2. Attach the lower bracket to the air springs with the two 3/8”-16x7/8” bolts, lock washers, and flat washers (Figure 5).
3. Tighten the bellows to both brackets to 20 ft. lbs.

## INSTALLING THE SPRING ASSEMBLY

1. Set the air spring assembly on the leaf spring over the axle.

### NOTE

*NOTE: Some vehicles may require the leaf spring U-bolts to be trimmed to allow the bottom bracket to fit properly (Figure 7).*

2. Attach the lower bracket to the leaf spring using provided U-bolts, flat washers and lock nuts as shown in Figure 1.
3. Torque to 20 ft./lbs.

## ADJUSTING YOUR KIT

1. Align the assembly vertically and horizontally (Figure 7). There must be sufficient clearance between the air springs, the frame, and the tire and brake drum at the maximum inflated diameter (7.0"). Tighten the upper bracket and mounting bolts for the bellows to 20 ft./lbs.
2. On some vehicles the outer flange of the axle jounce bumper bracket extends out from the frame rail. Trim the outer flange of the bracket or remove the bracket assembly entirely to provide sufficient clearance from bellows to the frame for the maximum inflated diameter (7.0").
3. Position the upper bracket so that it is parallel with the lower bracket.

### NOTE

*The kit mounts so that it follows the angle of the leaf springs.*

4. Align the assembly vertically and horizontally. The distances between points X and Y (Figures 6 and 7) should be approximately equal, between 5 and 7 at normal ride height.

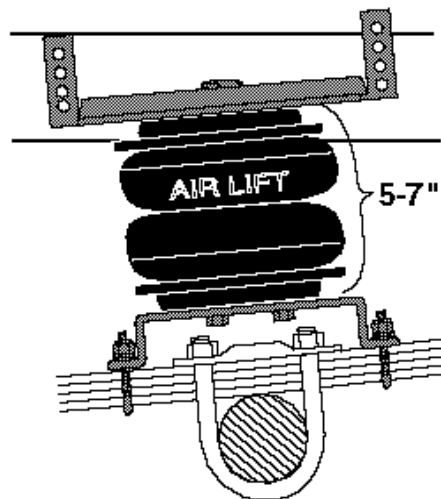

fig. 6

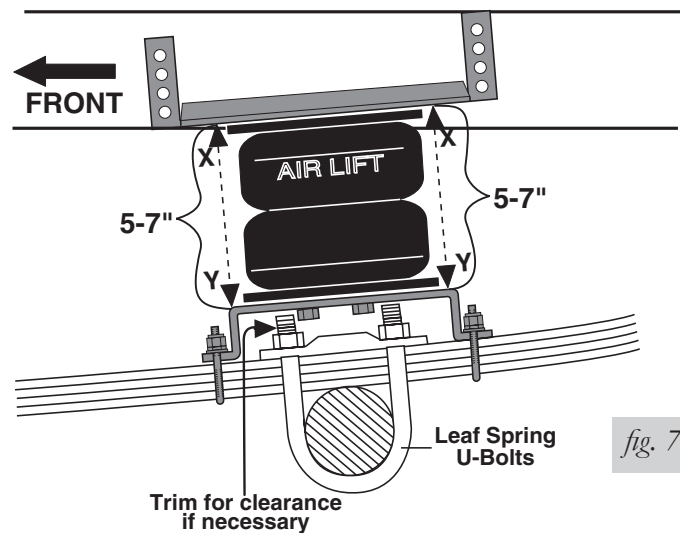

fig. 7

5. Adjust the upper bracket so that at least four bolt holes (two on each side) will be on a flat section of the frame rail. Use the widest bolt spacing possible. Do not drill on the radiused edges of the frame. Clamp the upper bracket to the frame rail with a C-clamp or welding clamp. Before marking any holes, check the following:

1. Are four holes in the upper bracket positioned on flat section of the frame rail?
2. Are the upper and lower brackets aligned vertically with each other?
3. Are the distances between points X and points Y equal?
4. Is the distance between the upper and lower brackets between 5" and 7"?

**CAUTION**

DO NOT DRILL HOLES INTO THE FRAME UNTIL HYDRAULIC LINES, GAS LINES AND ELECTRICAL WIRES HAVE BEEN MOVED ASIDE ON BOTH SIDES OF THE FRAME.

6. Center punch and drill one 3/8" locator hole through the frame at one bolt location and install one 1.5" washerhead frame bolt, over-sized washer, and lock nut.
7. Check the alignment of the upper and lower bracket once again to be sure that the distances between points X and points Y are equal and between 5 and 7 inches. Center punch and drill one more 3/8" hole on the opposite side, install one 1.5" washerhead frame bolt, over-sized washer and lock nut.
8. Remove the clamps and drill the remaining two holes. Install the remaining hardware and tighten all nuts to 20 ft./lbs.
9. Using the slots in the upper bracket, align the air springs both inboard and outboard. Tighten the air springs to the brackets to 20 ft./lbs.
10. Repeat the procedure for the other side of the vehicle.

## INSTALLING THE AIR LINES

**NOTE**

When installing the air lines, there must be at least six inches of clearance between the air lines and any heat sources.

1. Insert a length of air line into the open port at the top of the air spring. Use Figure 9 as an air line routing guide.

### Air Line Cutting

fig. 8

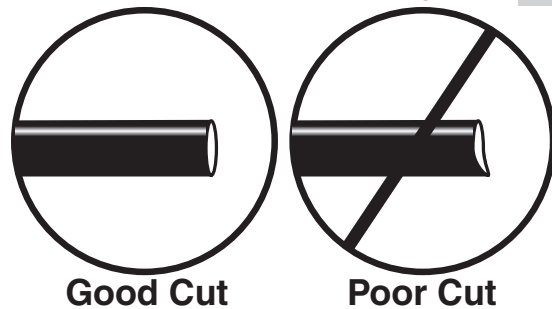
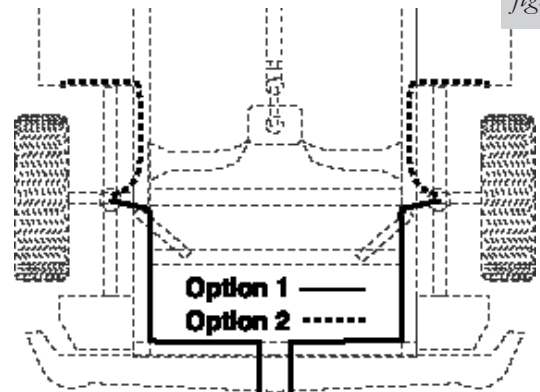

fig. 9



- Choose a convenient location for mounting the inflation valves. Popular locations for the inflation valve are:  
The wheel well flanges; The license plate recess in bumper; Under the gas cap access door; Through license plate.

## NOTE

Whatever the chosen location is, make sure there is enough clearance around the inflation valves for an air chuck.

- Drill a  $\frac{5}{16}$ " hole to install the inflation valves.
- Cut the air line assembly (AA) in two equal lengths.

## NOTE

When cutting or trimming the air line, use a hose cutter (Air Lift P/N 10530), a razor blade or a sharp knife. A clean, square cut will ensure against leaks. Do not use wire cutters or scissors to cut the air line. These tools may flatten or crimp the air line causing it to leak around the O-ring seal inside the elbow fitting.

- Install the inflation valves as shown in Figure 10.

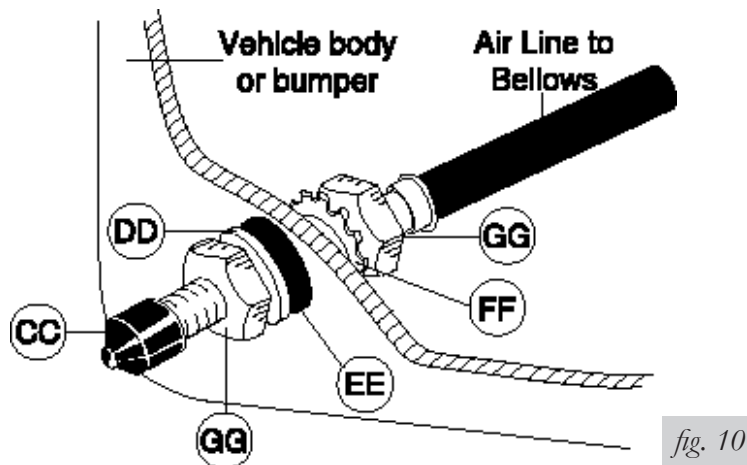

- Keep at least 6" of clearance between the air line and heat sources, such as the exhaust pipes, muffler, or catalytic converter. Avoid sharp bends and edges. Leave at least 2" of slack when securing the air lines to allow for any movement that might pull on the air line.
- Cut off air line leaving approximately 12" of extra air line. Insert the air line into the air fitting. Simply push the air line into the 90° swivel fitting until it bottoms out ( $\frac{9}{16}$ " of air line should be in the fitting).

## CHECKING FOR LEAKS

- Inflate the air spring to 30 p.s.i.
- Spray all connections and the inflation valves with a solution of  $\frac{1}{5}$  liquid dish soap and  $\frac{4}{5}$  water to check for leaks. You should be able to spot leaks easily by looking for bubbles in the soapy water.
- After the test, deflate the springs to the minimum pressure required to restore the Normal Ride Height, but not less than 5 p.s.i.

## NOTE

Check the air pressure again after 24 hours. A 2 to 4 p.s.i. loss after initial installation is normal. Retest for leaks if the loss is more than 5 lbs.

## FIXING LEAKS

1. If there is a problem with the swivel fitting, then:
  - a. Check the air line connection by deflating the spring and removing the line by pulling the collar against the fitting and pulling firmly on the air line. Trim 1" off the end of the air line. Be sure the cut is clean and square. Reinsert the air line into the push-to-connect fitting.
  - b. Check the threaded connection by tightening the swivel fitting another 1/2 turn. If it still leaks, deflate the air spring, remove the fitting, and re-coat the threads with thread sealant. Reinstall by hand tightening as much as possible, then use a wrench for an additional two turns.
2. If there is a problem with the inflation valve, then:
  - a. Check the valve core by tightening it with a valve core tool.

# Before Operating

## INSTALLATION CHECKLIST (To be completed by installer)

- Clearance test — Inflate the air springs to 60 PSI and ensure there is at least ½” clearance around each bellow, away from anything that might rub against them. Be sure to check the tire, brake drum, frame, shock absorbers and brake cables.
- Leak test before road test — Inflate the air springs to 60 PSI, check all connections for leaks with a soapy water solution. See page 12 for tips on how to spot leaks. All leaks must be eliminated before the vehicle is road tested.
- Fastener test — Recheck all bolts for proper torque. Axle clamp bar carriage bolt lock nuts should be torqued to 16 ft/lbs. Re-torque after 100 miles.
- Road test — The vehicle should be road tested after the preceding tests. Inflate the air springs to 25 PSI (50 PSI if the vehicle is loaded). Drive the vehicle 10 miles and recheck for clearance, loose fasteners and air leaks.
- Operating instructions — If professionally installed, the installer should review the Product Use, Maintenance and Servicing section on page 14 with the owner. Be sure to provide the owner with all of the paperwork which came with the kit.

**Technician's Signature** \_\_\_\_\_

**Date** \_\_\_\_\_

## POST-INSTALLATION CHECKLIST

- Overnight leak down test — Recheck air pressure after the vehicle has been used for 24 hours. If the pressure has dropped more than 5 PSI, then there is a leak that must be fixed. Either fix the leak yourself or return to the installer for service.
- Air pressure requirements — Regardless of load, the air pressure should always be adjusted to maintain ride height at all times.
- Thirty day or 500 mile test — Recheck the air spring system after 30 days or 500 miles, whichever comes first. If any part shows signs of rubbing or abrasion, the source should be identified and moved, if possible. If it is not possible to relocate the cause of the abrasion, the air spring may need to be remounted. If professionally installed, the installer should be consulted. Check all fasteners for tightness.

# Product Use, Maintenance and Servicing

Minimum Recommended Pressure	Maximum Air Pressure
5 PSI	100 PSI

## MAINTENANCE GUIDELINES

### NOTE

*By following the steps below, vehicle owners will obtain the longest life and best results from their air springs.*

1. Check the air pressure weekly.
2. Always maintain normal ride height. Never inflate beyond 100 PSI.
3. If you develop an air leak in the system, use a soapy water solution (1/5 liquid dish soap and 4/5 water) to check all air line connections and the inflation valve core before deflating and removing the air spring.

### CAUTION

FOR YOUR SAFETY AND TO PREVENT POSSIBLE DAMAGE TO YOUR VEHICLE, DO NOT EXCEED MAXIMUM GROSS VEHICLE WEIGHT RATING (GVWR), AS INDICATED BY THE VEHICLE MANUFACTURER. ALTHOUGH YOUR AIR SPRINGS ARE RATED AT A MAXIMUM INFLATION PRESSURE OF 100 P.S.I., THE AIR PRESSURE ACTUALLY NEEDED IS DEPENDANT ON YOUR LOAD AND GVWR.

4. Loaded vehicles require at least 25 PSI or more. A “loaded vehicle” refers to a vehicle with a heavy bed load, a trailer, or both. As discussed above, never exceed GVWR, regardless of air spring, air pressure, or other load assist. The springs in this kit will support approximately 40 lbs. of load (combined on both springs) for each 1 PSI of pressure. The required air pressure will vary depending on the state of the original suspension. Operating the vehicle below the minimum air spring pressure will void the Air Lift warranty.
5. When increasing load, always adjust the air pressure to maintain the normal ride height. Increase or decrease pressure from the system as necessary to attain normal ride height for optimal ride and handling. Remember that loads carried behind the axle (including tongue loads) require more leveling force (pressure) than those carried directly over the axle.
6. Always add air to springs in small quantities, checking the pressure frequently.
7. Should it become necessary to raise the vehicle by the frame, make sure the system is at minimum pressure (5 PSI) to reduce the tension on the suspension/brake components. Use of on board leveling systems do not require deflation or disconnection.
8. Periodically check the air spring system fasteners for tightness. Also, check the air springs for any signs of rubbing. Realign if necessary.
9. On occasion, give the air springs a hard spray with a garden hose in order to remove mud, sand, gravel or other abrasive debris.

## TROUBLESHOOTING GUIDE

1. Leak test the air line connections, the threaded connection into the air spring, and all fittings in the control system.
2. Inspect the air lines to be sure none are pinched. Tie straps may be too tight. Loosen or replace the strap and replace leaking components.
3. Inspect the air line for holes and cracks. Replace as needed.
4. Look for a kink or fold in the air line. Reroute as needed.

If the preceding steps do not solve the problem, it is possibly caused by a failed air spring — either a factory defect or an operating problem. Please call Air Lift at (800) 248-0892 for assistance.

## FREQUENTLY ASKED QUESTIONS

### Q. Will installing air springs increase the weight ratings of a vehicle?

No. Adding air springs will not change the weight ratings (GAWR, GCWR and/or GVWR) of a vehicle. Exceeding the GVWR is dangerous and voids the Air Lift warranty.

### Q. Is it necessary to keep air in the air springs at all times and how much pressure will they need?

For LoadLifter 5000 Ultimate, the recommended minimum air pressure is 5 PSI, but it can safely be run at zero air pressure.

### Q. Is it necessary to add a compressor system to the air springs?

No. Air pressure can be adjusted with any type of compressor as long as it can produce sufficient pressure to service the springs. Even a bicycle tire pump can be used, but it's a lot of work.

### Q. How long should air springs last?

If the air springs are properly installed and maintained they can last indefinitely.

### Q. Will raising the vehicle on a hoist for service work damage the air springs?

No. The vehicle can be lifted on a hoist for short-term service work such as tire rotation or oil changes. However, if the vehicle will be on the hoist for a prolonged period of time, support the axle with jack stands in order to take the tension off of the air springs.

## TUNING THE AIR PRESSURE

Pressure determination comes down to three things — level vehicle, ride comfort, and stability.

### 1. Level vehicle

If the vehicle's headlights are shining into the trees or the vehicle is leaning to one side, then it is not level (fig. 2.1). Raise the air pressure to correct either of these problems and level the vehicle.

### 2. Ride comfort

If the vehicle has a rough or harsh ride it may be due to either too much pressure or not enough (fig. 2.2). Try different pressures to determine the best ride comfort.

### 3. Stability

Stability translates into safety and should be the priority, meaning the driver may need to sacrifice a perfectly level and comfortable ride. Stability issues include roll control, bounce, dive during braking and sponginess (fig. 2.3). Tuning out these problems usually requires an increase in pressure.



Bad headlight aim *fig. 2.1*



Rough ride *fig. 2.2*



Sway and body roll *fig. 2.3*

## GUIDELINES FOR ADDING AIR

1. Start with the vehicle level or slightly above.
2. When in doubt, always add air.
3. If the front of the vehicle dives while braking, increase the pressure in the front air bags, if equipped.
4. If it is ever suspected that the air bags have bottomed out, increase the pressure (fig. 2.4).
5. Adjust the pressure up and down to find the best ride.
6. If the vehicle rocks and rolls, adjust the air pressure to reduce movement.
7. It may be necessary to maintain different pressures on each side of the vehicle. Loads such as water, fuel, and appliances will cause the vehicle to be heavier on one side (fig. 2.5). As much as a 50 PSI difference is not uncommon.



Bottoming out

*fig. 2.4*

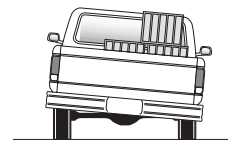

Unlevel

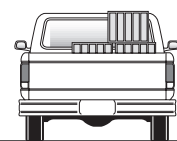

Level

*fig. 2.5*

# Choosing the Right On-Board Air Compressor System

**60 DAY** NO QUESTIONS ASKED, MONEY-BACK GUARANTEE

**TWO YEAR** COMPRESSOR SYSTEM WARRANTY

Add an on-board air compressor system to inflate and deflate your air springs with the touch of a button — from inside or outside of the vehicle.

- For convenient, on-the-go control of your air springs, add an Air Lift on-board air compressor system.
- Air Lift on-board air compressor systems eliminate the search for gas stations that have a working compressor, saving you time, energy and money.
- All systems include a compressor, controller and all parts needed for easy installation.

**1. Choose single or dual path inflation (see illustrations at right)**

**2. Choose wireless or analog control**

- **Wireless:** Control your air springs from inside or outside the vehicle. Easiest installation - no wires to the cab.
- **Analog:** In-cab control of your air springs. Economically priced.

**3. Choose heavy or standard duty compressor**

- **Standard duty:** A standard duty compressor will work well for most customers who use their system on an intermittent basis.
- **Heavy duty:** For daily use, consider the heavy duty compressor - it inflates faster and more quietly than the standard compressor.

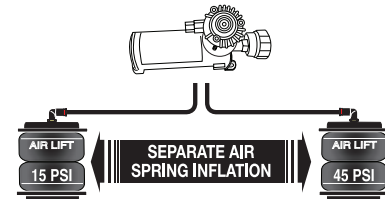

*Dual path systems* Air springs are controlled separately to allow for different air pressure from side-to-side. Perfect for uneven or top-heavy loads.

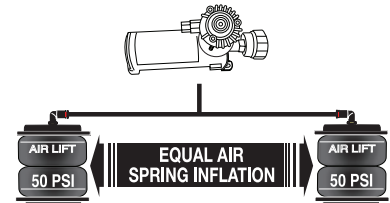

*Single path systems* Two springs will inflate at the same time. Good for loads that are evenly distributed from left-to-right or front-to-back.

W I R E L E S S

A N A L O G

DUAL PATH

**WirelessAIR™**

**OUR PREMIUM SYSTEM!**

- Easy installation
- Includes heavy duty compressor



P/N 72000

SINGLE PATH

**WirelessONE™**

- Easy installation
- Includes standard duty compressor



P/N 25870

**LoadCONTROLLER™**

**Dual**

Compact, economically priced control.



P/N Standard Duty Compressor 25850; P/N Heavy Duty Compressor 25854

**LoadCONTROLLER™**

**Single**

Compact, economically priced control.



P/N Standard Duty Compressor 25852; P/N Heavy Duty Compressor 25856