



This bracket is designed to be used with the non-metric Chevrolet pump with attached reservoir. There are a large number of pumps available from 1961 to 1981 that will work well with our power steering bracket. For more detailed information see the enclosed power steering pump sheet.

POWER STEERING PUMP MOUNT

417L

Small Block Chevy - Driver's Side
Electric Water Pump

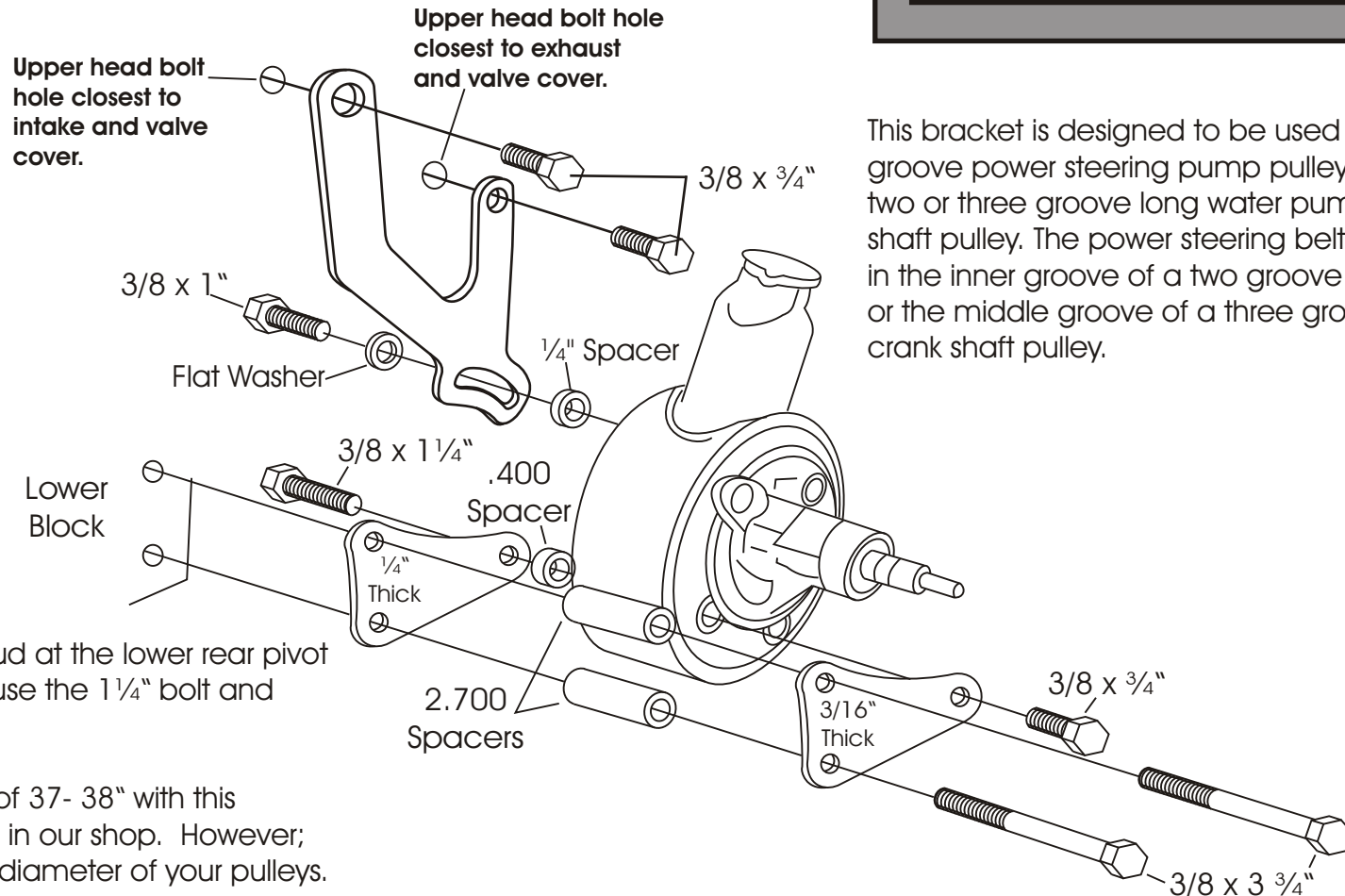

This bracket is designed to be used with a 1 groove power steering pump pulley, and a two or three groove long water pump crank shaft pulley. The power steering belt will run in the inner groove of a two groove crank, or the middle groove of a three groove crank shaft pulley.

If your pump has a stud at the lower rear pivot point, remove it and use the 1 1/4" bolt and .400 spacer.

We use a belt length of 37- 38" with this mount on installations in our shop. However; this can vary with the diameter of your pulleys.

As with any part of this nature, make sure it fits your application before painting or plating. Parts that have been painted, plated, or modified may not be returned.