

INSTALLATION GUIDE

AMP Power Step RESEARCH MADE IN USA

APPLICATION	MODEL YR	PART #
Dodge Ram Regular Cab * 2500/3500	2019 - 2020	76243-01A
Dodge Ram Crew Cab 2500/3500	2019 - 2020	76243-01A
Dodge Ram Mega Cab 2500/3500	2019 - 2020	76243-01A

*Modification required to running board assembly. See Item 1 on page 3.

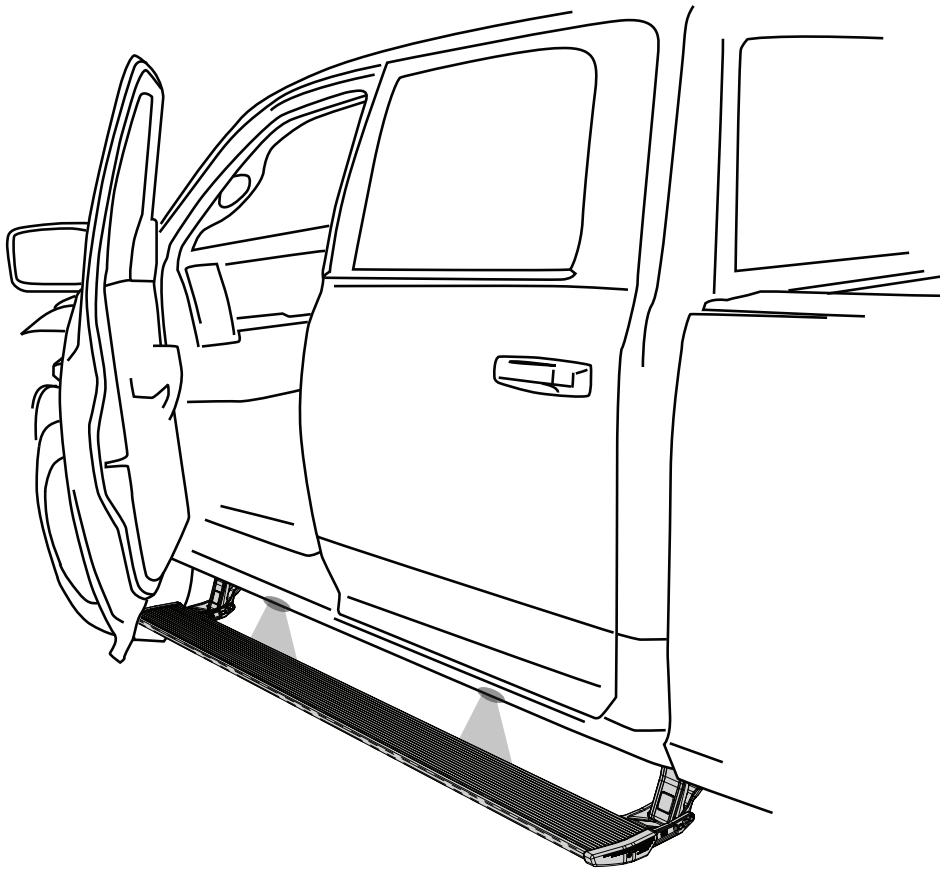

INSTALLATION TIME

3-5 Hours

Professional installation recommended

SKILL LEVEL



4= Experienced

TOOLS REQUIRED

- Safety goggles
- Measuring tape
- 13mm wrench
- 19mm wrench
- 13mm socket
- 10mm socket
- Ratchet wrench and extension
- Wire stripper / cutter
- 3/16" hex key (allen wrench)
- 4mm hex key (allen wrench)
- Rivet Tool
- 1/8", 9/32" and 3/16" Drill Bit
- T27 torx Bit
- Center Punch
- Anti Corrosion Paint
- Electrical tape

INSTALLATION GUIDE

Motor to linkage assembly

NOTE: The motors will be attached on step 16 (page 8).

EXPLODED VIEW

- Motor
- Socket cap screw
- Washer
- Drive Gear Housing Cover

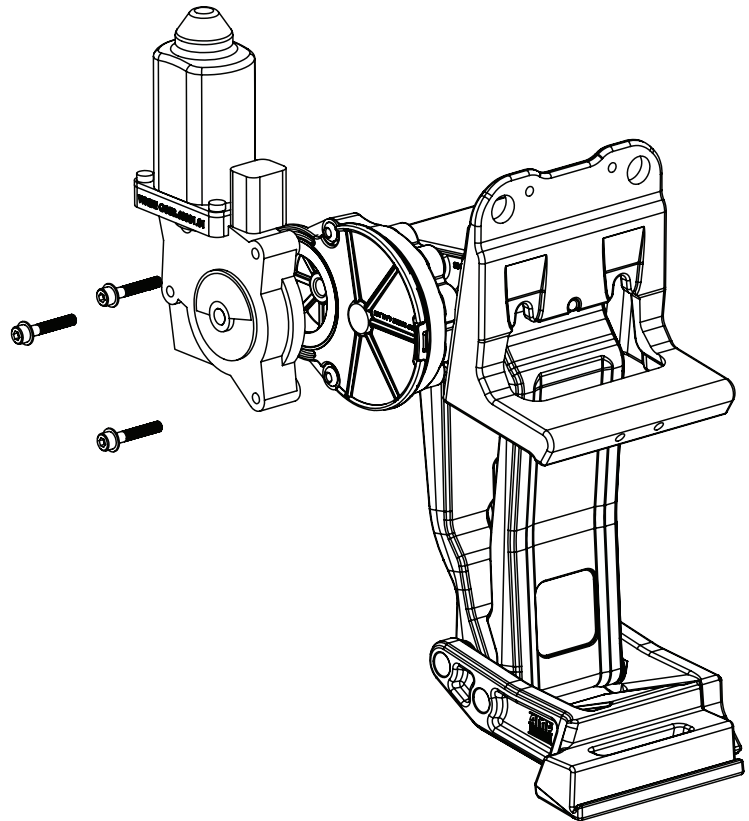

CAUTION: HANDLE WITH CARE.

To ensure our customers receive all components with full integrity, we pack the motors separate from their linkage assemblies. This requires that the installer position and fasten the motor before continuing with the install. Please follow the instructions below and handle the assembly carefully.

CAUTION: Dropping the assembly or any excessive impact MAY cause damage to the motor.

Instructions:

1. Position the gear cover in place as shown if not already in place.
2. Seat motor into position on the three mounting bosses. This may require an adjustment of the gear by moving the swing arms.
3. After seating into place, fasten the motor with the three motor mount screws with 4mm Hex Head. Tighten screws to 36 in-lbs (4N-m). **Do not over torque.**

Note: Some Applications require modification

Application	Cut Length
Crew Cab, Mega Cab	79" (No Modification Required)
Regular Cab	50" (Trim 29")

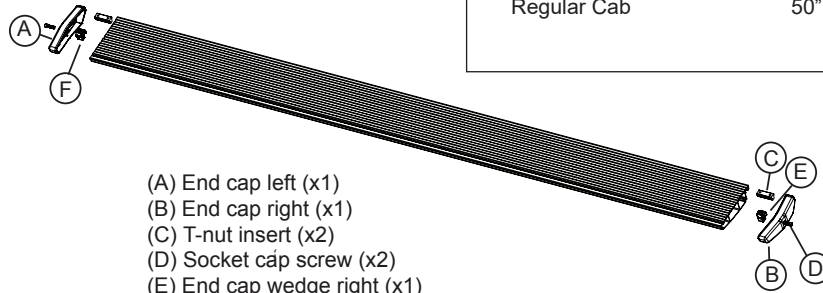

- (A) End cap left (x1)
- (B) End cap right (x1)
- (C) T-nut insert (x2)
- (D) Socket cap screw (x2)
- (E) End cap wedge right (x1)
- (F) End cap wedge left (x1)

1 x2

Running board assembly

Driver Side Linkages

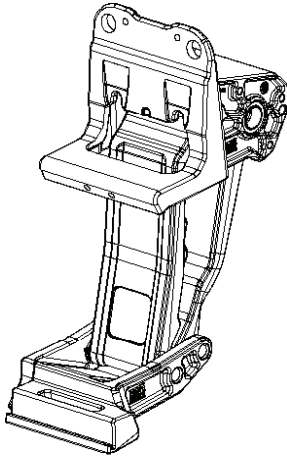

2a

Front Idler Linkage Assembly - Driver Side

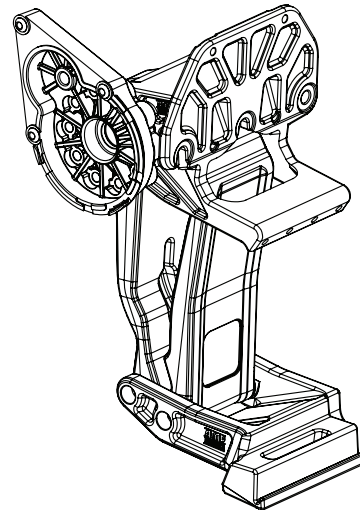

3a

Rear Motor Linkage Assembly - Driver Side

Passenger Side Linkages

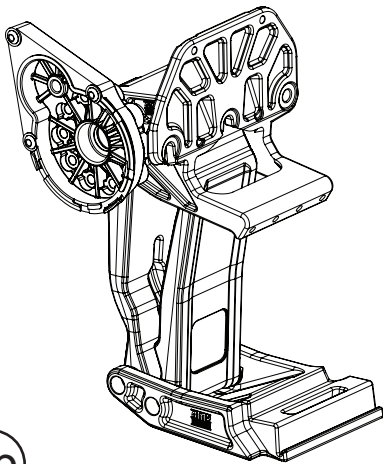

3b

Rear Motor Linkage Assembly - Passenger Side

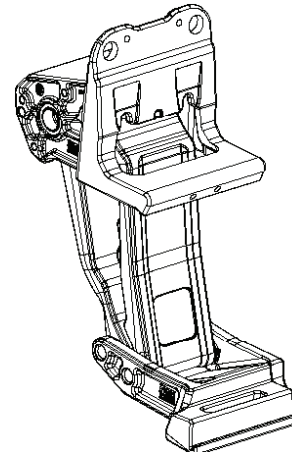

2b

Front Idler Linkage Assembly - Passenger Side

PARTS LIST AND HARDWARE IDENTIFICATION

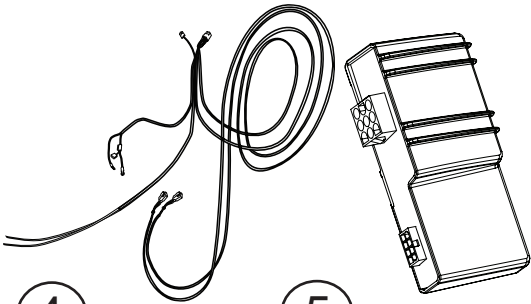

4

Wire Harness

5

STA Controller



6 x8

Rivet Nut

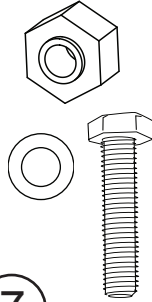

7

Rivet Nut Tool

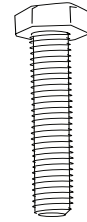

8 x8

M8 Hex bolt



9 x8

Blind Rivet



10 x8

Washer (SS)

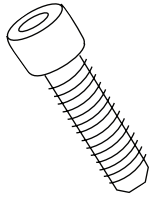

11 x8

Socket Cap Screw

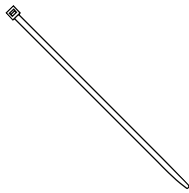

12 x20

Cable Tie (7'')

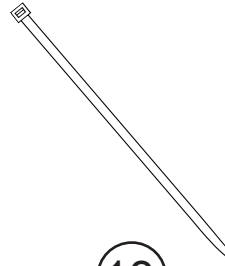

13 x2

Cable Tie (11'')

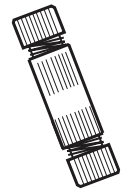

14 x2

Posi-Lock™
Connector



15 x8

Button Head Torx Screw



16 x8

Washer



17 x4

Grommet

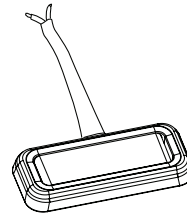

18 x4

LED Lamp

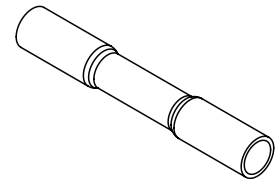

19 x8

Butt Connector

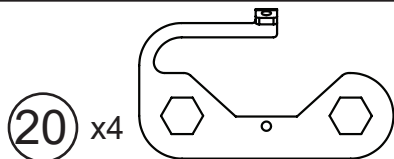

20 x4

Reinforcement Bracket



21 x4

Blind Rivet

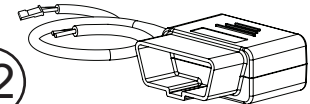

22

OBD II Plug

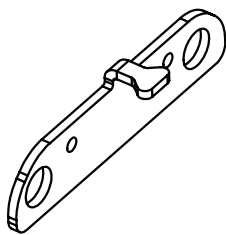

23 x2

Spacer (front drive linkage)

HARDWARE MOUNTING OVERVIEW (passenger side shown)

Locate forward most and rearward most mounting provisions on inner sill of truck. Remove tape from sill drain hole at both mounting points.

Note: Some vehicles may have Front welded fasteners installed already. Backing plates and rivet nuts are not needed on these locations. Factory Rivet nuts will need to be removed to install backing plates.

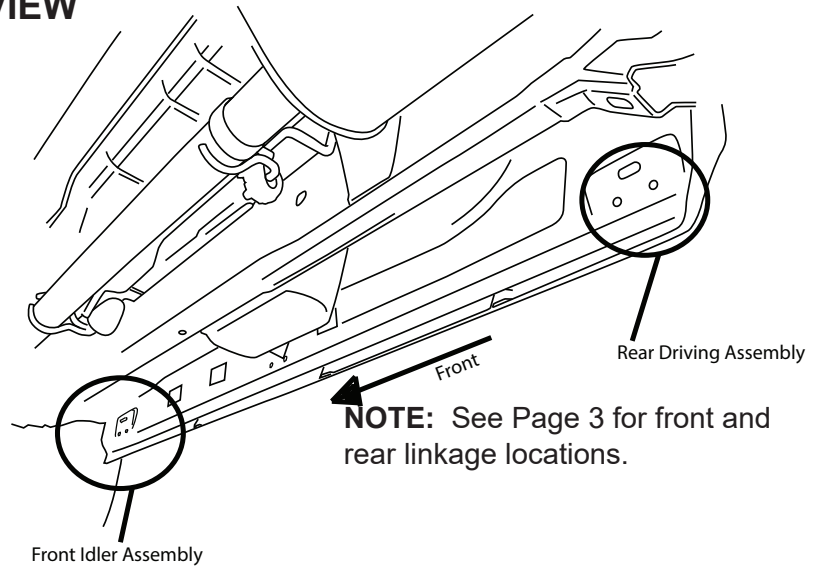

1

Set Reinforcement Plate in place and locate with rivet nuts. Drill hole using an 1/8" drill bit. After drilling apply paint to prevent rusting

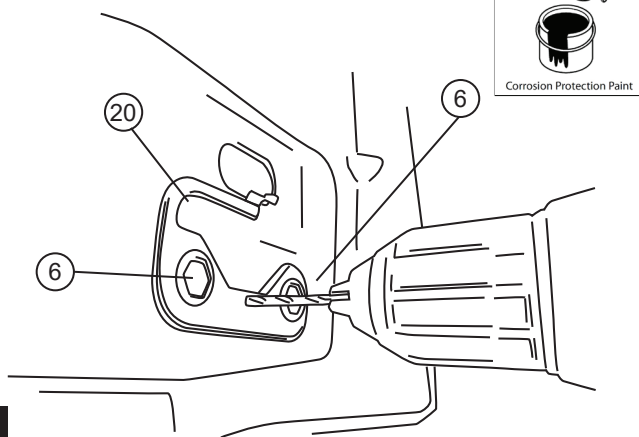

2

Once hole is drilled insert a piece of string or wire through hole in Reinforcement Plate. Set plate into position.

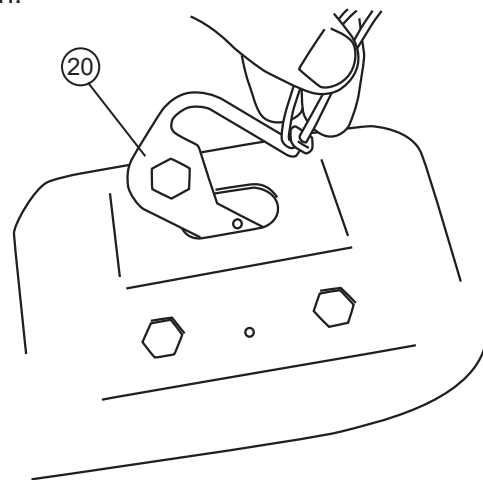

3

Set rivet nuts into place for alignment. Insert pop rivet through hole in plate and secure in place. Once pop rivet is installed remove string or wire from Reinforcement Plate. **NOTE: Verify plate is pulled flush to the body before securing pop rivet.**

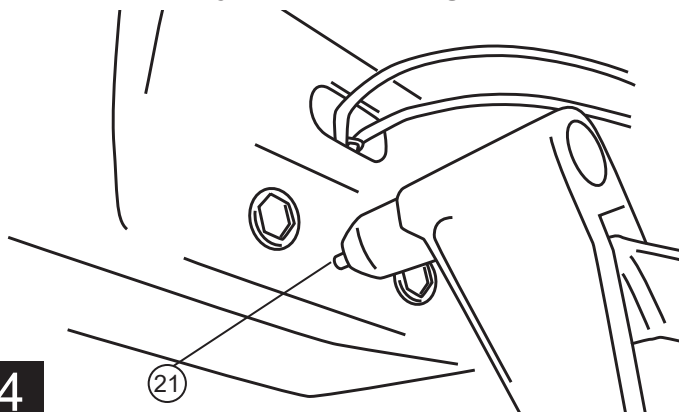

4

Assemble Hex Bolt (lubricated with soapy water), Washer, Rivet Tool, and Rivet Nut together as shown and place into hex cutouts in sill. An extra Hex Bolt and M8 Washer is supplied to install rivet nuts.

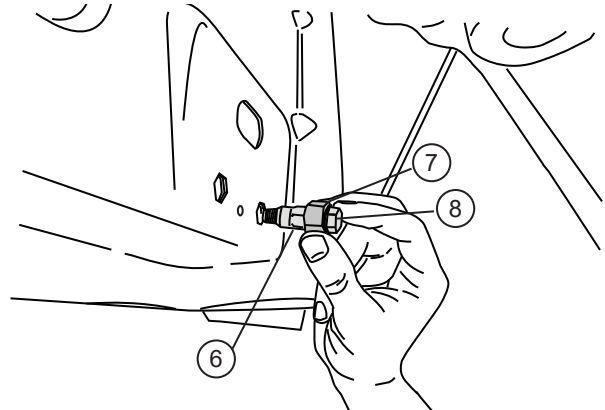

5

With Rivet Nut Tool held in place with 19mm wrench, tighten Hex Bolt until Rivet Nut deforms and secures itself to the sheet metal (110 in-Lbs. or 4 turns). Remove Hex Bolt and Rivet Nut Tool. Repeat for each of the four mentioned mounting locations.

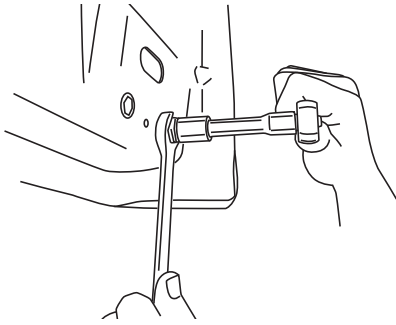

WARNING: Rivet Nuts not properly collapsed will not hold securely to sheet metal.

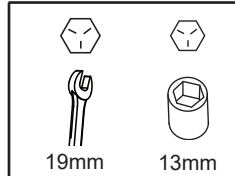

6 NOTE: Hold Rivet tool with wrench while loosening bolt.

Once rivet nuts are in place use a screwdriver to push back tab in hole to avoid interference with linkage mount.

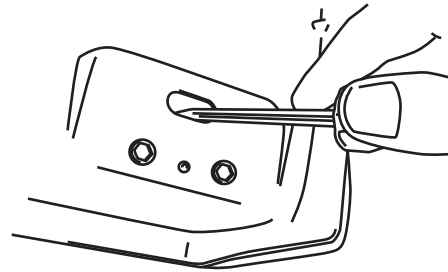

7

Linkage Installation: On rear linkages thread front hex bolt into rivet nut with washer. Note on Front drive linkages both hex bolts can be threaded into position.

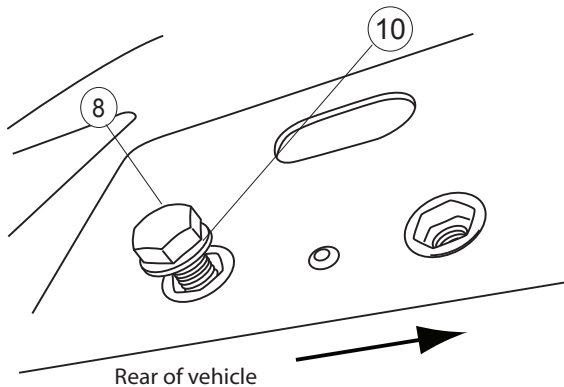

8 Passenger Side Rear mount position shown.

Rear Drive Linkage: With linkage in position insert Hex bolts into rivet nut locations. Snug bolts but do not tighten. **Note: Pre threaded bolt will attach to slot centered on linkage. Idler linkages will use 2 of the 3 mount points.**

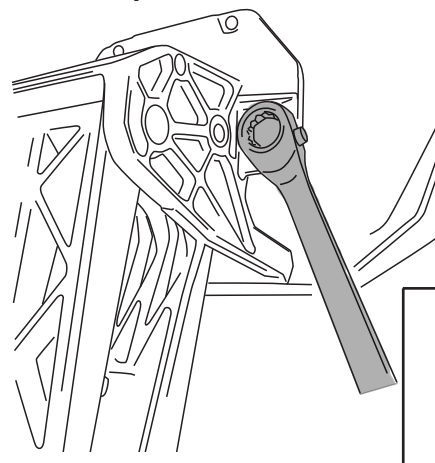

9

Front Idler Linkage: If crash bracket is not present use supplied spacer in place of bracket. Spacer can be inserted after linkage is up into position. Spacer will be held in place by drilling and pop riveting into place. **Rivets will be installed in step 32 & 33.**

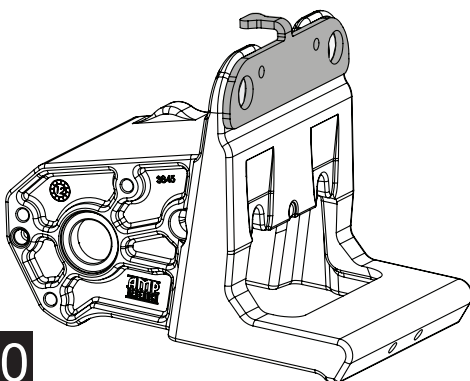

10

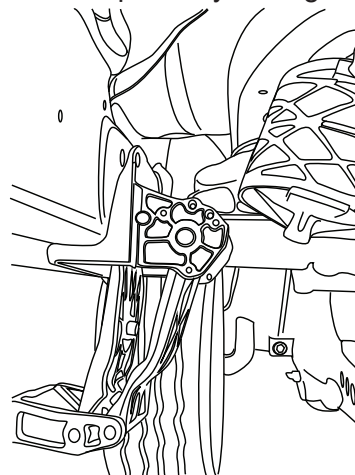

AMP RESEARCH POWERSTEP™ – DODGE RAM

All Linkages: Slide linkage over pre threaded bolts. Using a T27 Torx driver start torx bolts and washers. Snug bolts but do not tighten. Replace bolts from step 15 if present.

Using a 13mm wrench tighten two hex bolts on linkage. Torque to 16 ft-lbs. Torque bolts from step 15 if present to 50 ft-lbs.

11

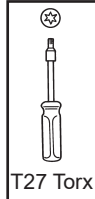
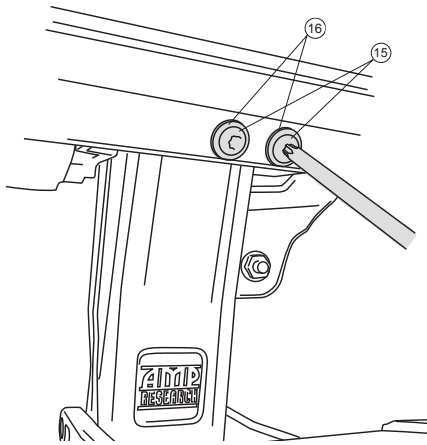

12

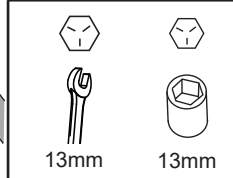
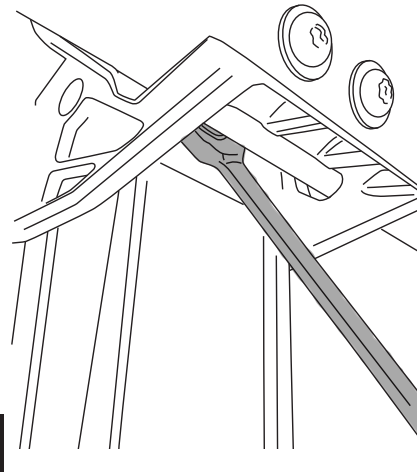

Using a T27 Torx driver torque bolts to 6 ft-lbs.

13

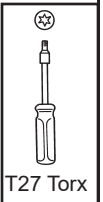
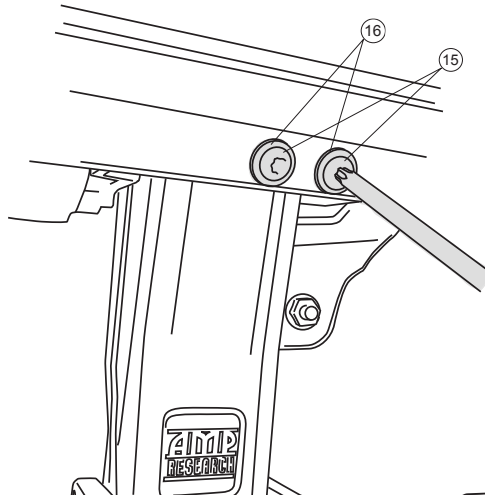

The jogs in the lower part of the linkages point toward one another, as shown, Note: Linkage position described in parts list on page 3.

14

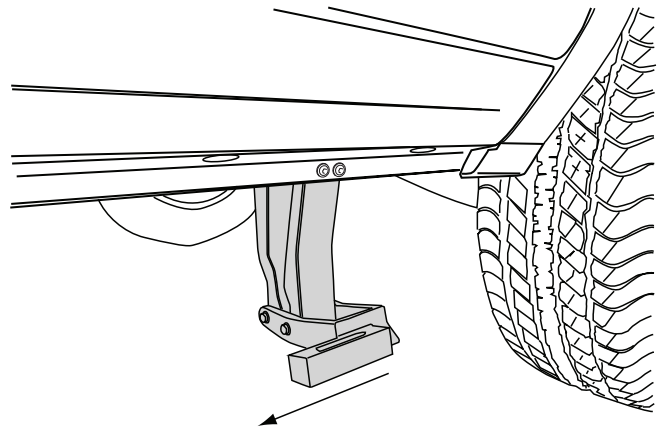
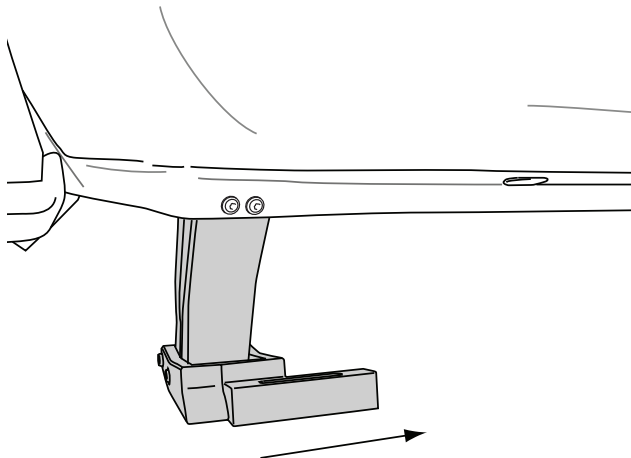

Install boards: . Slide mounting T-Nut of board into position and attach to linkages. Shift board forward as much as possible for proper clearance. The end of board/end cap will nest into linkage lower mount 1/2" when positioned correctly. **With boards in extended position step on boards to seat linkages. Walk the length of the board taking bouncing steps. DO NOT JUMP ON BOARD! Verify that board end caps do not contact the pinch weld. If Endcaps make contact loosen 4 button head screws at pinch weld. Walk the length of the board and apply weight to the center of the board and while applying weight retighten button head screws at pinch weld. Hand Cycle Boards to ensure Pinch weld clearance.**

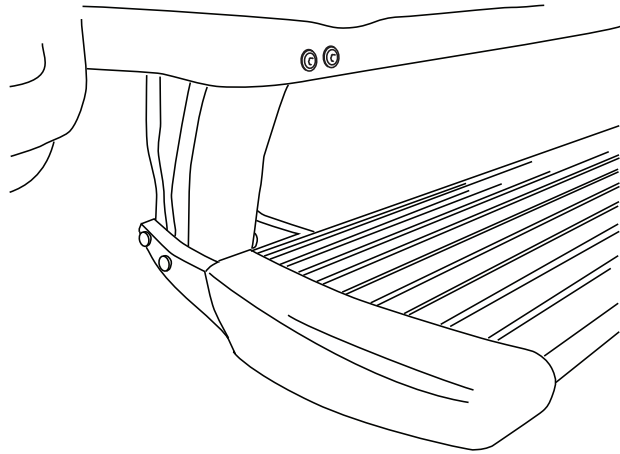

Torque to 10 ft-lbs. (13.5 Nm)

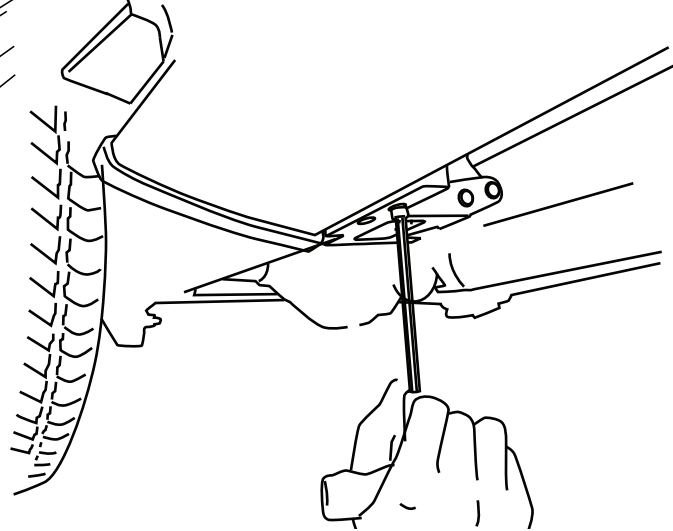

15

Using a 4mm hex key torque bolts to 36 in-lbs.
See page 2 for motor installation instructions.

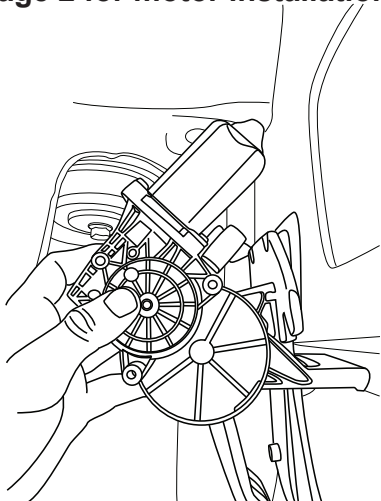

Route the two Wire Harness legs down over the wheel wells toward Motor Linkages, long leg across to the passenger side. Secure harness with tie wraps.

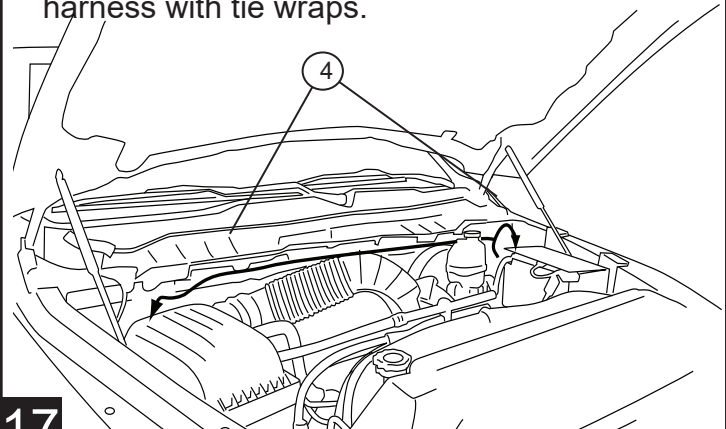

16

17

Prepare large tie-wraps for mounting Power Step Controller. Loosely loop tie-wraps around large bundle of wires behind battery in engine compartment.

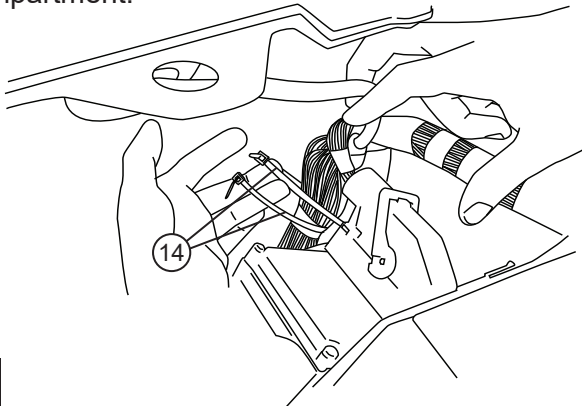

18

Insert controller into tie-wrap loops and cinch down securely. The tie-wraps should cinch down into channels on controller surface.

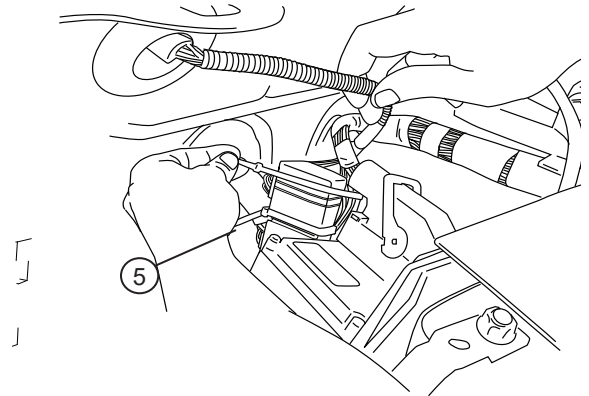

19

Remove fuse from Power Step Wire Harness.

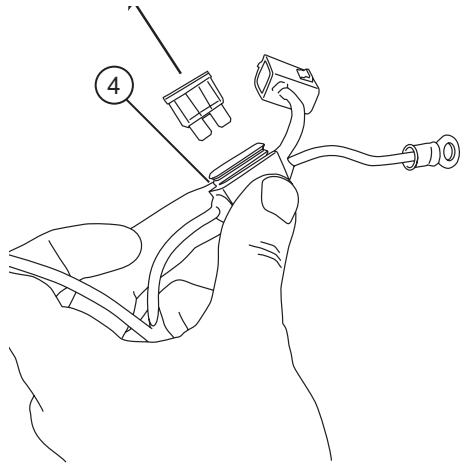

20

Connect power leads from Controller, Red to positive battery terminal and Black to the vehicle body ground as shown.

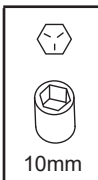
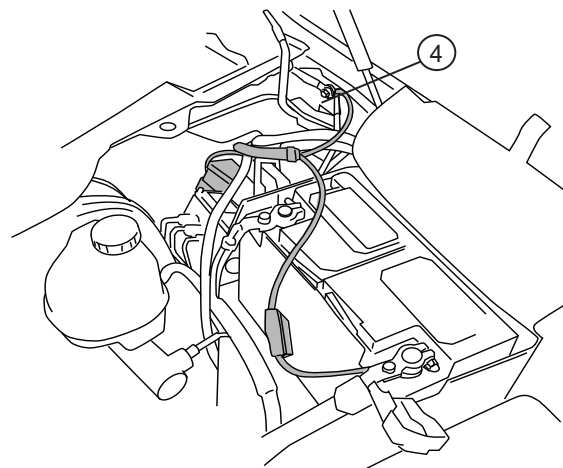

Locate large rubber wire boot on driver side firewall as shown below. Slice small opening as shown below to run trigger wires through.

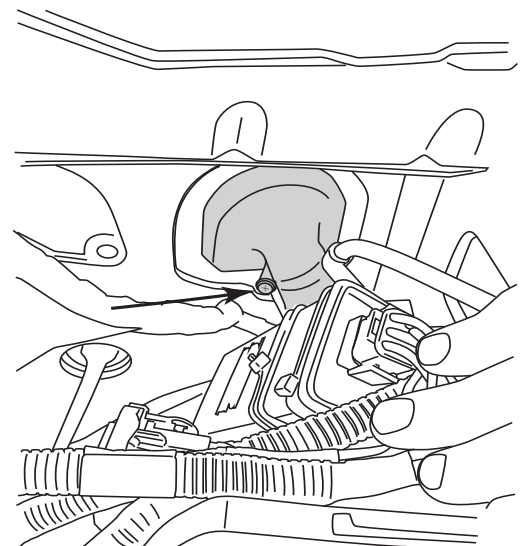

21

Tape leading end of wires together and push through rubber boot to cabin side of the firewall. Silicon lubricant may be used for ease of passage. The trigger wires will come out just above and to the left of the brake pedal.

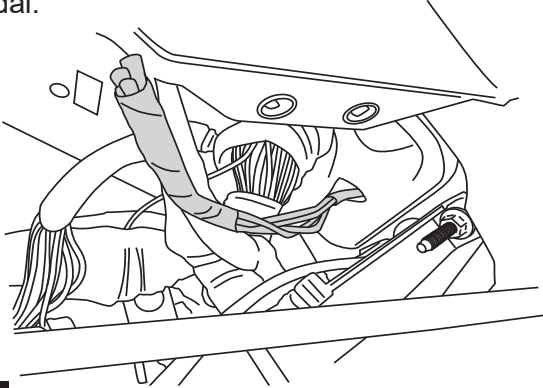

22

Locate Green Connector Block under dash to the left of the steering column. The 2 pin plug off the OBD harness will plug into one of the open ports on this green plug.

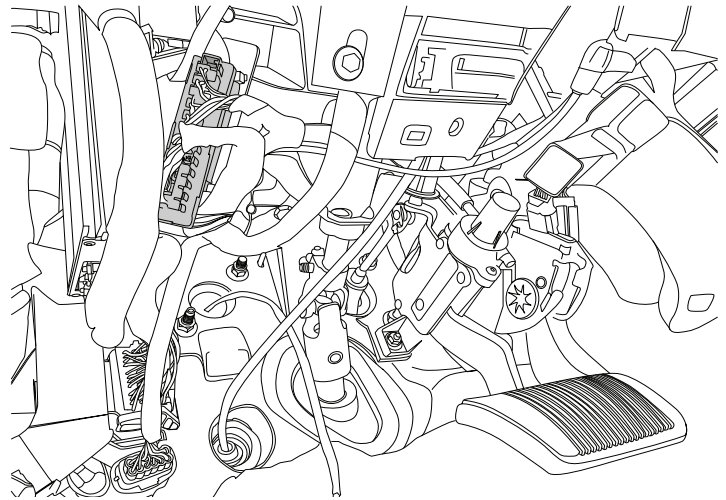

23

Plug 2 pin plug into the Green Connector Block. Use supplied Posi-Lock connectors to attach the Plug and Play module to the Harness. Attach Matching colors on the harness to the wires on the module. Plug in module to the OBD II port on the vehicle. Secure harness with supplied tie wraps.

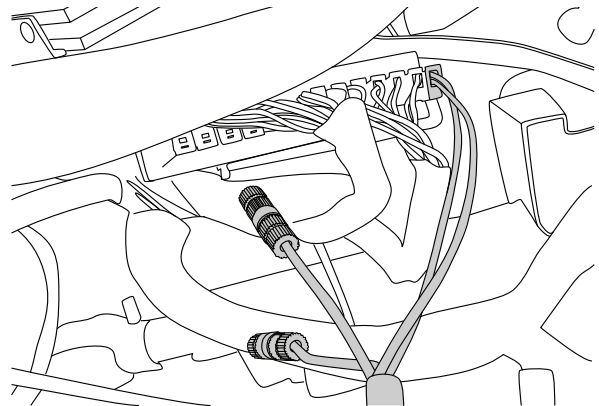
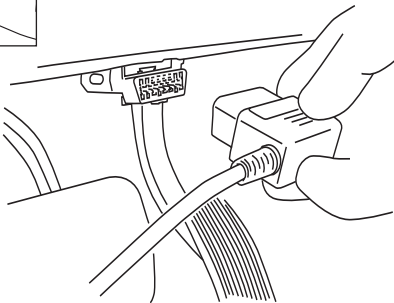
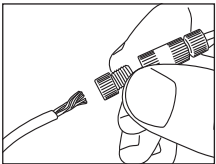

24

Secure harness with supplied tie wraps. Make sure wires are away from E-brake mechanism and brake pedal assembly.

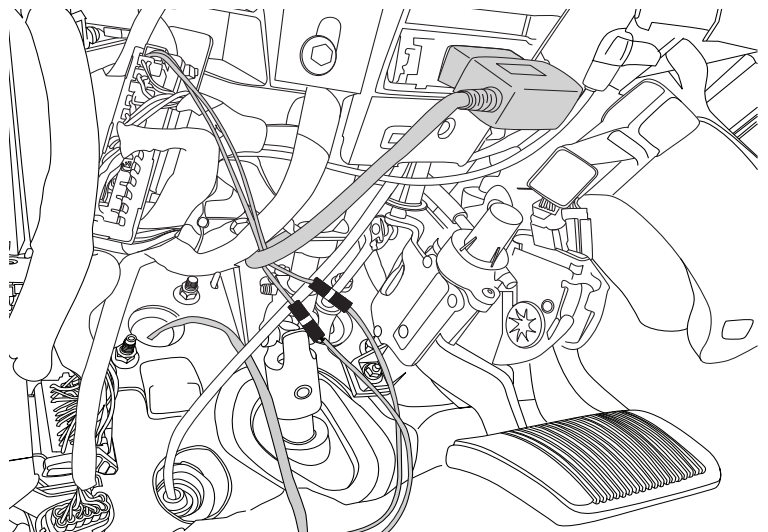

25

OBD II install: Use Supplied Posi-Lock connectors to attach the Plug and Play Module to the Harness. Attach matching colors on the harness to the wires on the module. Plug in module to OBD II port on the vehicle. Secure harness with supplied tie wraps.

Note: If the OBD II pass thru harness (76404-01A) was purchased see install sheet supplied in packaging. The pass through harness allows for an open port for other accessories. See below for a brief description.

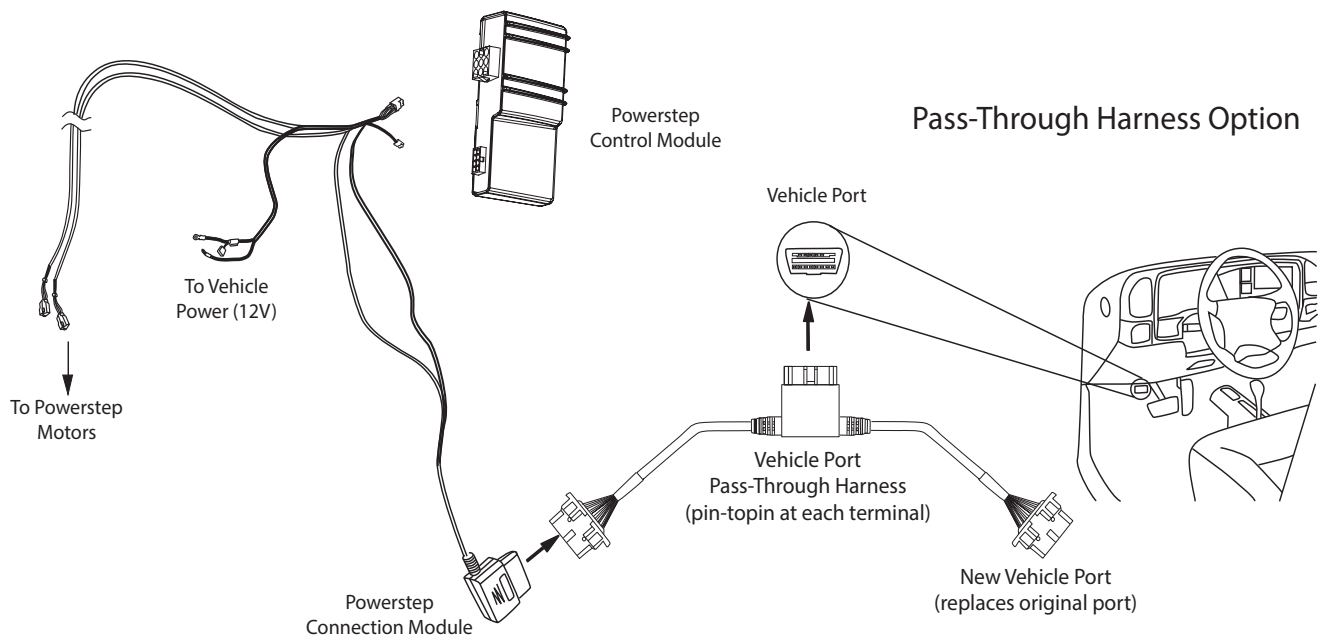
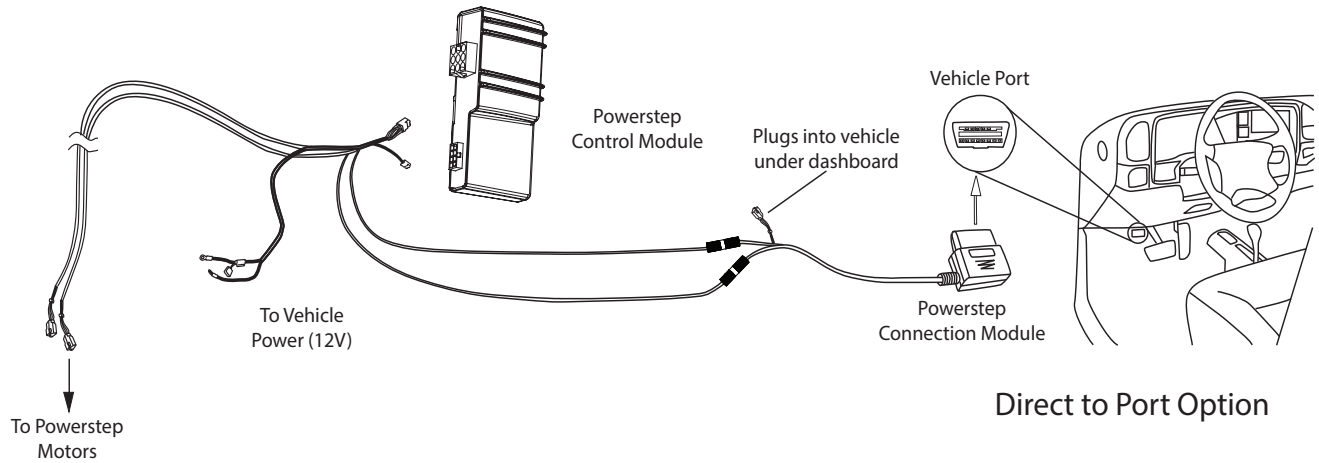

AMP RESEARCH POWERSTEP™ – DODGE RAM

On each side of the vehicle measure from the front edge of door line on the pinch weld to the specified lengths below. Measure at 22" for the front LED Light and 64-3/4" for the rear LED Light. **Note for Quad cabs mount lights at 22" and 54" for Regular cabs mount lights at 10" and 45".**

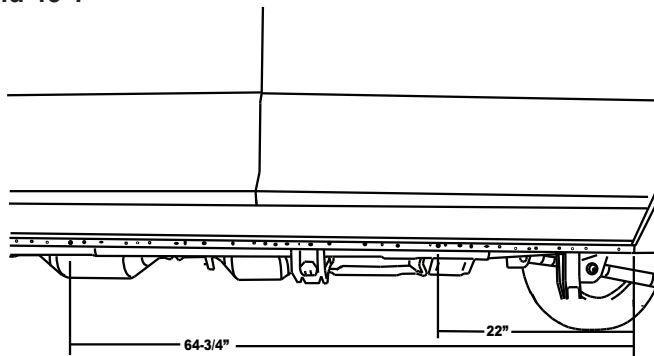

27

Drill a 9/32" hole through the pinch weld at marked locations. Deburr all holes. After drilling apply paint to holes to prevent rusting.

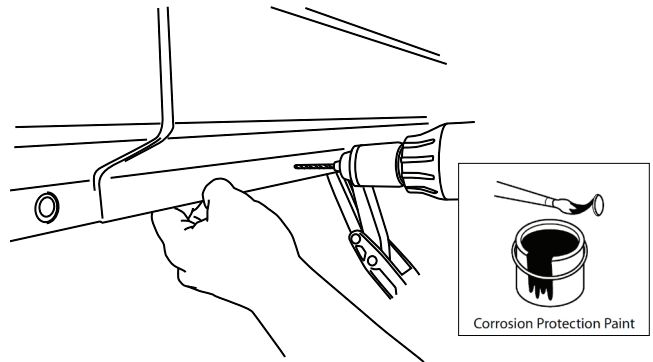

28

Insert grommet into drilled holes. Insert lamp wires through the grommets. (Silicon lube will help wires slip through grommets.)

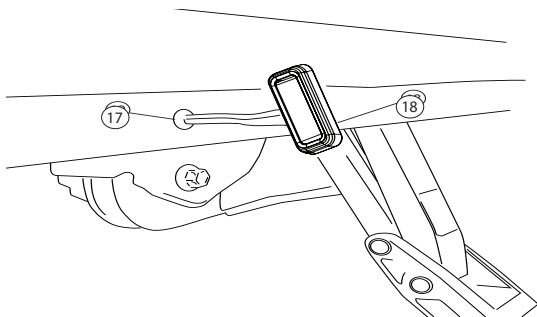

29

Affix lamp to rocker panel surface. Make sure lamp is affixed to a flat, clean surface.

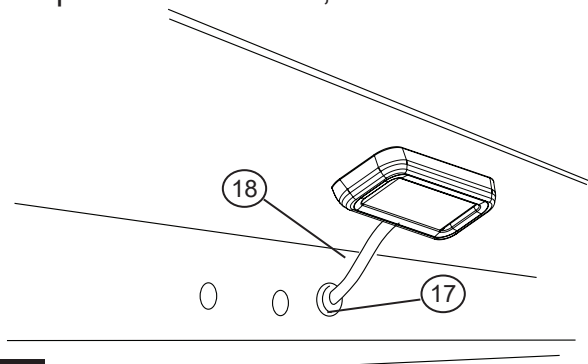

30

Using supplied butt connectors, connect the lamp wires. Red to Red, Black to Black. Once Crimped use heat gun to shrink tube. Close and wrap with conduit and electrical tape. Secure all loose wires with cable ties, with lamp wires pulled upward to avoid any wire snagging.

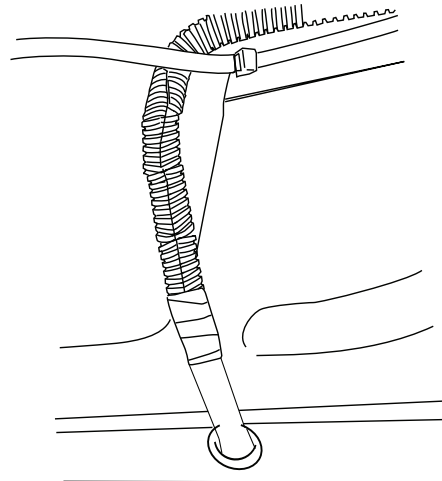
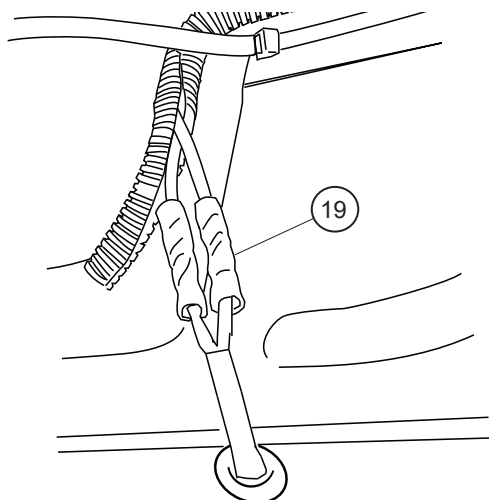

31

With linkage resting square on the hex bolts Using a 3/16" Drill bit, drill both upper holes in linkage through sheetmetal. After drilling apply paint to holes to prevent rusting.

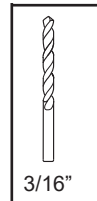
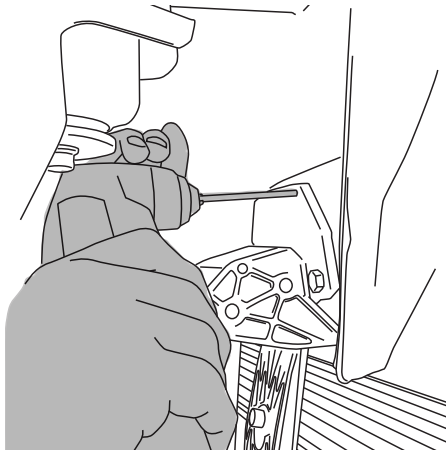

Using a Rivet Gun install rivets.

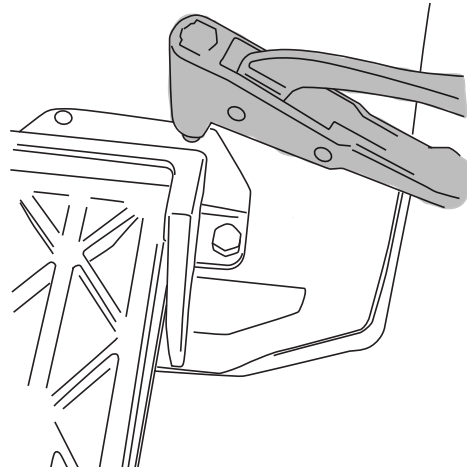

32

33

Check that all doors activate the Power Step and the LED Lights work when doors open and close. Reinstall any remaining trim panels.

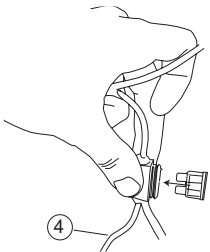
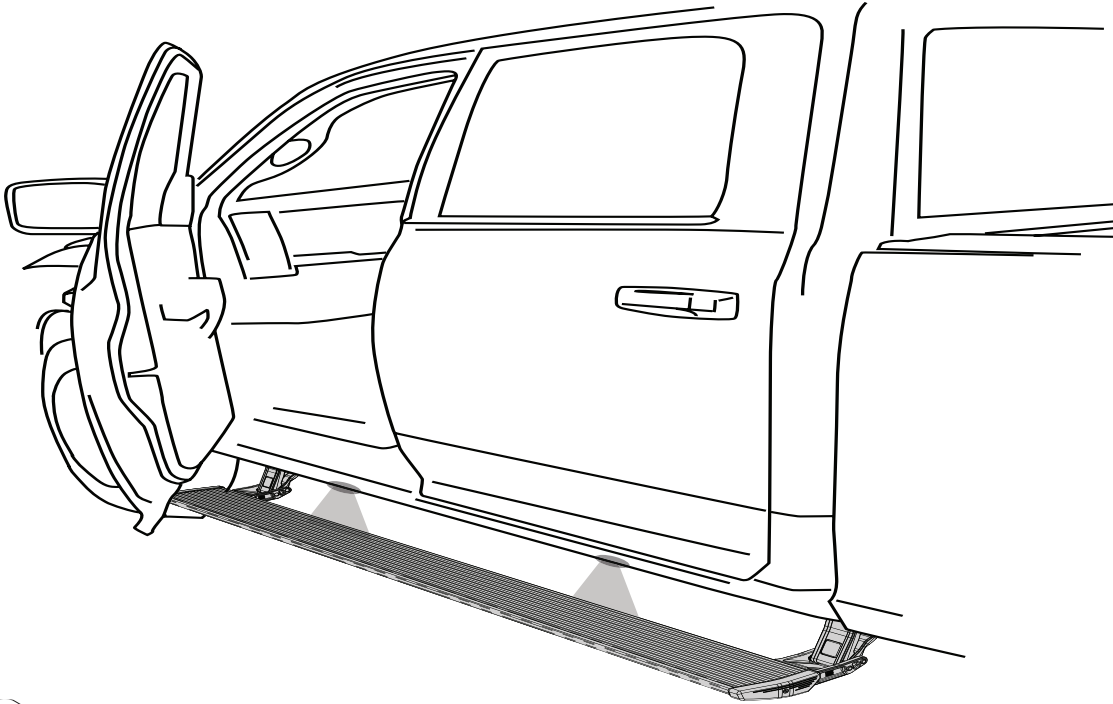

FINAL SYSTEM CHECK

Check that all doors activate the PowerStep and the LED lights work when doors open and close.

NORMAL OPERATION: When the doors open, PowerStep automatically deploys from under the vehicle. When the doors are closed, PowerStep will automatically return to the stowed/retracted position. **Note that**

CORRECT OPERATION OF LIGHTS: All four lamps will illuminate upon opening any door of vehicle. Lamps will stay on until restowing of both Power Steps or until 5 minutes has expired with the doors open. When the lights timeout after 5 minutes, they can be reilluminated by closing and opening any door of vehicle.

POWER-DEPLOYABLE RUNNING BOARDS OPERATION: AMP Research PowerStep running boards automatically move when the doors are opened to assist entering and exiting the vehicle.

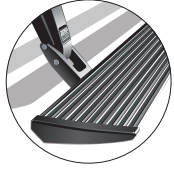

Automatic power deploy:

The running boards will extend down and out when the doors are opened.

Automatic power stow:

The running boards will return to the stowed position when the doors are closed. There will be a 2-second delay before the running boards move to the stowed position.

Automatic stop:

If an object is in the way of the moving running board, the running board will automatically stop. To reset, clear any obstruction, then simply open and close the door to resume normal operation.



Manually set in the deployed (OUT) position for access to the roof:

The running boards can be manually set in the deployed position by firmly holding the step down with your foot while at the same time closing the door. To resume normal operation, open and close the door.

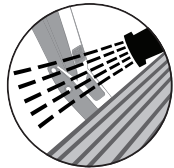

Maintenance: In adverse conditions, debris such as mud, dirt, and salt may become trapped in the running board mechanism, possibly leading to unwanted noise. If this occurs, manually set the running boards to the deployed position and flush the front and rear hinge arms with a high-pressure car wash wand. Avoid spraying the motors directly. After washing, apply silicone spray lubricant to the hinge pivot pins. Do not apply silicone, wax or protectants like Armor All® to the running board stepping surface.

Caution! Keep hands away when the running board is in motion.