



FITTING INSTRUCTIONS

Part Number: **3438270 F/Kit 6172557**
Product **Deluxe Combination Winch and Non Winch [Bull Bar](#)**
Description:
Suited to **Nissan XTERRA 050N USA Only**
vehicle/s:

WARNING

REGARDING VEHICLES EQUIPPED WITH SRS AIRBAG:

When installed in accordance with these instructions, the front protection bar does not affect operation of the SRS airbag.

ALSO, NOTE THE FOLLOWING:

- ◆ This product must be installed exactly as per these instructions using only the hardware supplied.
- ◆ In the event of damage to any bull bar component, contact your nearest authorised ARB stockist. Repairs or modifications to the impact absorption system must not be attempted.
- ◆ Do not use this product for any vehicle make or model, other than those specified by ARB.
- ◆ Do not remove labels from this bull bar.
- ◆ This product or its fixing must not be modified in any way.
- ◆ The installation of this product may require the use of specialized tools and/or techniques
- ◆ It is recommended that this product is only installed by trained personnel
- ◆ These instructions are correct as at the publication date. ARB Corporation Ltd. cannot be held responsible for the impact of any changes subsequently made by the vehicle manufacturer
- ◆ During installation, it is the duty of the installer to check correct operation/clearances of all components
- ◆ Work safely at all times
- ◆ Unless otherwise instructed, tighten fasteners to specified torque

GENERAL CARE AND MAINTENANCE

By choosing an ARB Bar, you have bought a product that is one of the most sought after 4WD products in the world. Your bar is a properly engineered, reliable, quality accessory that represents excellent value. To keep your bar in original condition it is important to care and maintain it following these recommendations:



- Prior to exposure to the weather your bar should be treated to a Canuba based polish on all exposed surfaces. It is recommended that this is performed on a six monthly basis or following exposure to salt, mud, sand or other contaminants.
- As part of any Pre Trip Preparation, or on an annual basis, it is recommended that a thorough visual inspection of the bar is carried out, making sure that all bolts and other components are torqued to the correct specification. Also check that all wiring sheaths, connectors, and fittings are free of damage. Replace any components as necessary. This service can be performed by your local authorized ARB Stockist.

FITTING REQUIREMENTS

REQUIRED TOOLS FOR FITMENT OF PRODUCT:

METRIC SOCKET SET	METRIC RING AND OPEN ENDED SPANNER SET
ELECTRIC DRILL	3 & 10mm DRILL BITS
SHARP KNIFE	PHILLIPS AND FLAT SCREW DRIVER SET
FELT TIP PEN	HACKSAW BLADE OR SMALL HAND SAW
FINE FILE OR SAND PAPER	ELECTRIC JIG SAW
METRIC TAPE MEASURE	ROLLS OF 12 mm & 50 mm WIDE MASKING TAPE

HAVE AVAILABLE THESE SAFETY ITEMS WHEN FITTING PRODUCT:

Protective eyewear		Hearing protection	
--------------------	---	--------------------	---

NOTE: 'WARNING' notes in the fitting procedure relate to OHS situations, where to avoid a potentially hazardous situation it is suggested that protective safety gear be worn or a safe work procedure be employed. If these notes and warnings are not heeded, injury may result.

FASTENER TORQUE SETTINGS:

SIZE	Torque Nm	Torque lbft
M6	9Nm	7lbft
M8	22Nm	16lbft
M10	44Nm	32lbft
M12	77Nm	57lbft

NOTE:

- ◆ OPTIONAL FOG LAMPS TO SUIT THIS PRODUCT ARE P#6821201. IF LOOM AND SWITCH REQUIRED USE P#MD02 LOOM KIT, P#180209 SWITCH AND P#180215 SWITCH CAP FOR FOGS
- ◆ UP TO 900 SERIES ROUND OR 800 RECTANGULAR DRIVING OR FOG LAMPS SUIT THIS PRODUCT

PARTS LISTING

APPLICATION.	PART NO.	QTY	DESCRIPTION
MOUNT BRACKET (IMPACT ABSORBER) TO CHASSIS	3757756R&L	1 PR	BRACKET ASSY IMP ABS RH & LH
	6151095	8	BOLT M12 X 1.25 X 35 (FINE PITCH)
	4581049	8	WASHER FLAT M12
	4581050	8	WASHER SPRING M12
BULL BAR TO MOUNT BRACKETS	6151360	6	BOLT M12 X 1.75 X 35 (COARSE PITCH)
	4581007	6	WASHER FLAT M12 X 37 X 4
	4581050	6	WASHER SPRING M12
	6151428	6	NUT FLANGED M12
BUFFERS TO BULL BAR	3162470R&L	1 PR	BUFFER SLOTTED RH & LH
	6151128	12	NUT FLANGED M6
LICENCE PLATE TO BULL BAR	6151384	2	SCREW PAN HD
	6821189	2	GROMMET RND HD
LIGHT INSERT AND INDICATORS	3163015	1	COMBINATION LIGHT SURROUND KIT
	6821151R&L	1 PR	INDICATOR/CLEARANCE LAMP RH/ LH
	6821152	2	LOOM INDICATORS
	180701	6	SCOTCH LOKS
WINCH TO BULL BAR	3756499	1	CONTROL BOX MOUNT
	EG50	2	RUBBER GROMMET
	6151074	2	BOLT 3/8" x 1 3/4" HEX HEAD
	6151073	2	BOLT 3/8" x 1 1/2" HEX HEAD
	4581040	4	WASHER FLAT M10
	4581048	4	WASHER SPRING M10
	6151022	2	BOLT M8 x 25mm
	6151132	2	NUT FLANGE M8
	4581044	2	WASHER FLAT M8
	180302	6	CABLE TIES
WINCH COVER (NOT FITTING WINCH)	6522720	1	PANEL WINCH COVER
	6151256	2	SCREW M6 X 16MM BUTTON HEAD S/S
	6151128	2	NUT FLANGE M6
	6191006	1	EXTRUSION WINCH COVER
STONE TRAY BRACE TO IMPACT ABSORBERS	4681302	1	BRACE STONE TRAY
	6151022	2	BOLT M8 x 25 mm LONG
	4581044	2	WASHER FLAT M8
	4581046	2	WASHER SPRING M8
	6151132	2	NUT FLANGE M8
	6151300	2	CAGE NUT M6 (LONG LEG)
STONE TRAY TO BULL BAR	6522740	1	STONE TRAY
	6151300	4	CAGE NUT M6 (LONG LEG)
	6151213	6	BOLT M6 x 20 BZ
	4581082	6	WASHER FLAT M6 x 20 BZ
	4581287	6	WASHER SPRING M6 BZ
PINNING BOLT HARDWARE	6151357	4	BOLT SEMS M10 x 25 mm LONG
	6151321	4	NUT FLANGE M10
MISCELLANEOUS	180302	6	CABLE TIES
	6191020	2	PINCH WELD NARROW 400mm LONG
	6191024	1	PINCH WELD NARROW 600mm LONG
	3787028	1	TEMPLATE BUMPER CUT

PREPARATION TO VEHICLE

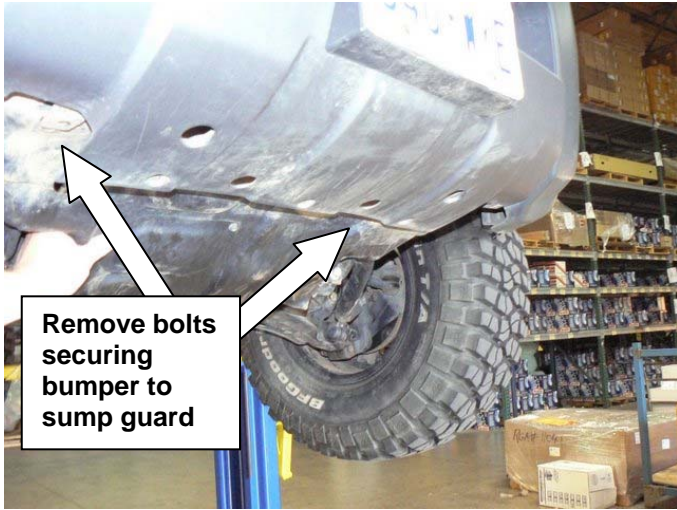

1. Remove licence plate from the vehicle and set aside
2. Remove the three plastic scrivenets securing the bumper in the intake area behind the licence plate location
3. Remove the bolts between the lower bumper and sump guard
4. Remove the four lower bolts that attach the lower bumper tabs to the vehicle (refer to attached photo). There are also another two self tapping screws in each side, located in a recess in the lower bumper face – these need to be removed.



5. Remove the two bolts and screw from the fender opening area each side that attaches the bumper bar to the plastic inner guard liner as shown.



6. Remove the screws securing the fender liners to bumper in the forward wheel arch areas



7. Remove the screws from the bumper on each side in the wheel arch area

PREPARATION TO VEHICLE



8. Remove the grille – prise out scrivenets along the top first, then release lower clips in behind grille attaching to top flange of the bumper



9. Remove scrivenets securing bumper to cross member.



10. Remove bumper.

11. Disconnect fog lamps if fitted

NOTE: *The outer end of the bumper where it clips into the fender, is released by pulling out and forward as shown*



PREPARATION TO VEHICLE



12. Remove bumper support panel
(2005 – 2008 MODEL ONLY)



13. Remove the four bolts that hold the factory steel sump guard, set aside to be fitted once bull bar is fitted.



14. Remove crash beam

PREPARATION TO VEHICLE



15. Remove tow hook and set aside

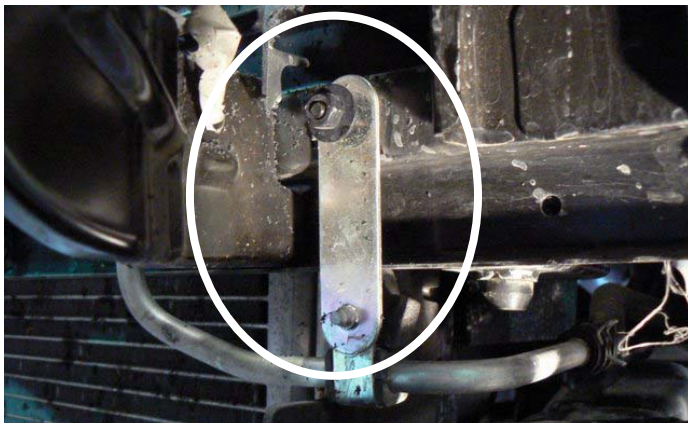

16. Remove the bracket holding the power steering pipe

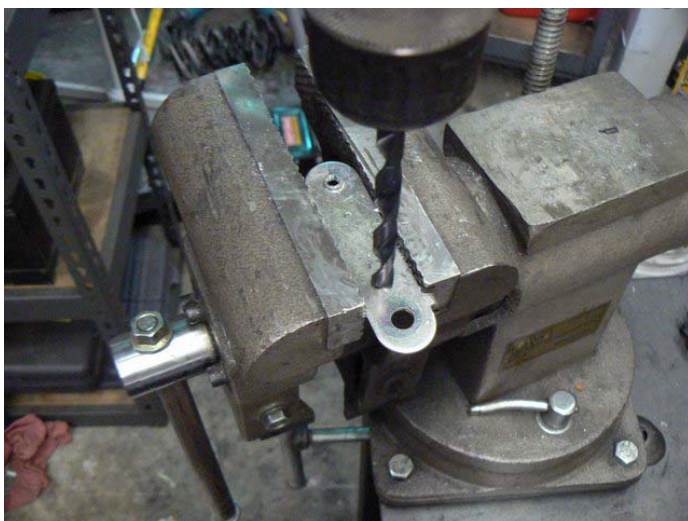

17. Mark out a hole 20mm (3/4") up from the original upper hole

18. Drill out to same diameter as upper hole as shown

19. Then flatten tab.

20. Touch up bare surfaces with rust preventing paint.



21. Pull up pipe and refit bracket as shown

PREPARATION TO VEHICLE

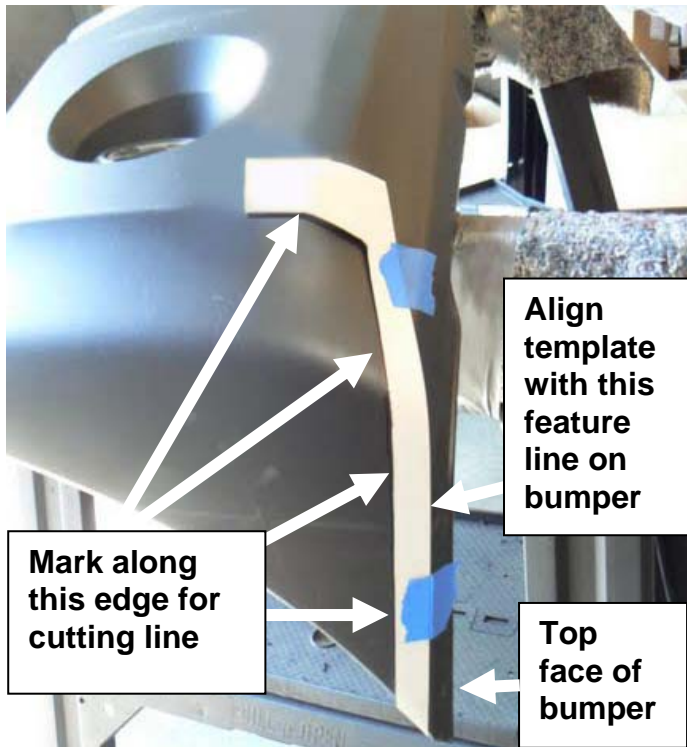

22. For marking out cut line, you may either temporarily refit bumper or mark out resting on saw stools or similar as shown.
23. You can begin marking out for the side cut on the bumper.
24. Starting on the LH side first, tape the template into position, aligning the edge along the top horizontal outward edge of the bumper and to the rear top corner as shown, then mark the cut line with a felt tip pen.
25. Repeat for the RHS

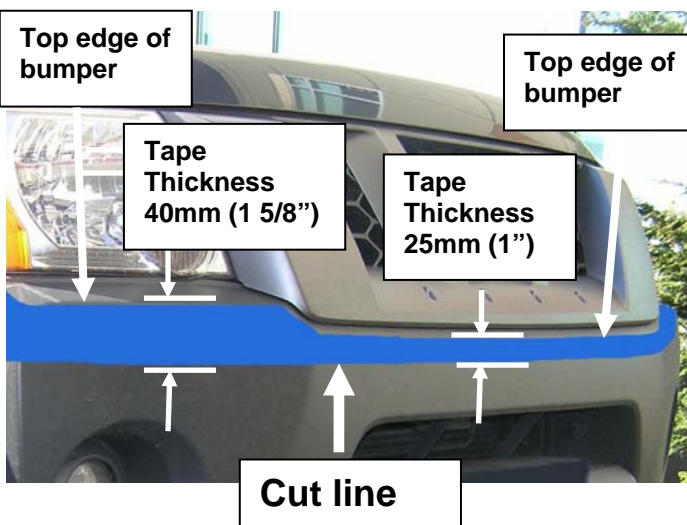

05-08 Xterra only

26. Apply tape across the front of the bumper as shown

PREPARATION TO VEHICLE

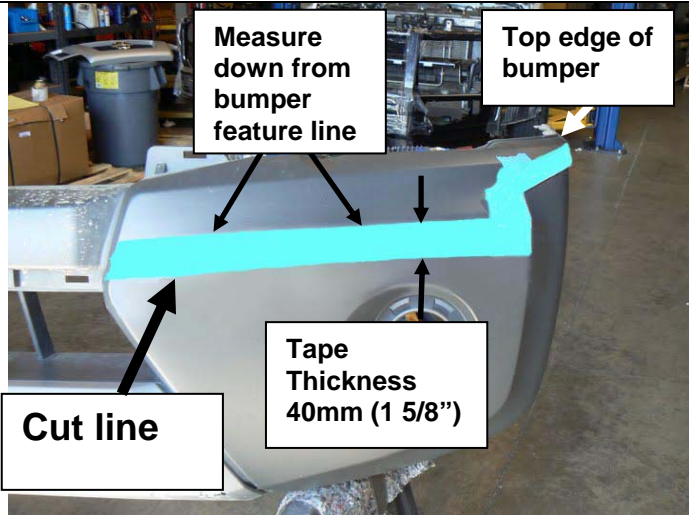

09 ON Xterra only

27. Apply tape across the front of the bumper as shown



28. Remove the template then mask the area above the cut with minimum of 30 mm masking tape to protect the surrounding surfaces.

29. Cut along the cutting line with an electric jig saw, or similar cutting device.

30. Clean up the cut edges of the bumper bar with a file or fine sand paper.

NOTE: Final bumper cut shown



09 ON Model showing cut up to edge of grille



Cut through ribs across centre section along area below

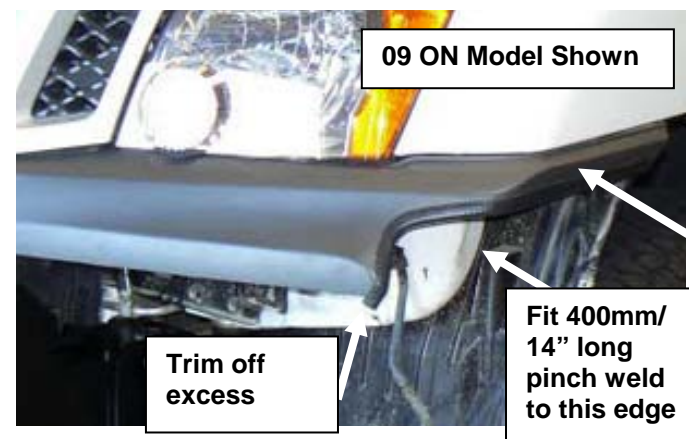

31. Fit the 400mm/14" long pinch weld trims to each of the areas from the wheel arch forward as shown

PREPARATION TO VEHICLE

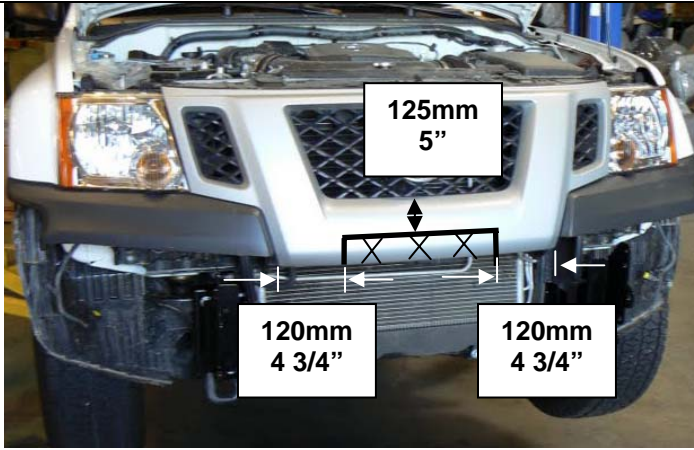

If you are fitting a winch in an 09ON model you must make this cut in the grille lower front area as shown

32. Mark out grille centre as shown

33. Make the cut, applying masking tape up to the cut line providing protection from scratching the good surface

NOTE: If fitting 9.5XP WARN winch check clearance when fitting and trim to clear

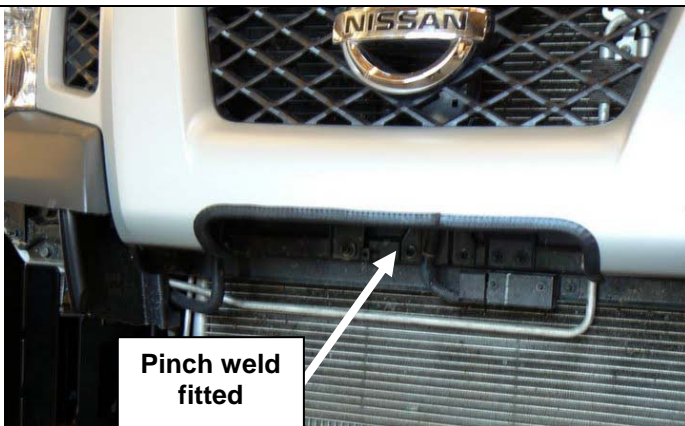

Pinch weld fitted

34. Apply the 600mm/26" piece of pinch weld to the edge and then trim any excess

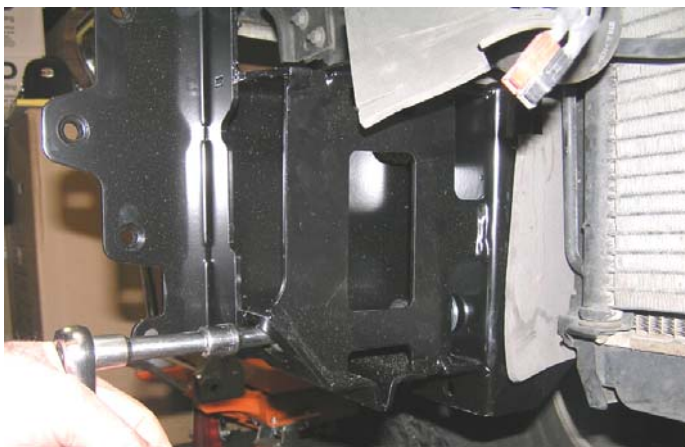

35. Install the impact absorber set as shown

36. Secure hand tight only, using M12 x1.25 X 35 bolt, washer and flange nut sets.

37. Use the original bolts to secure the tow hook if it is to be refitted

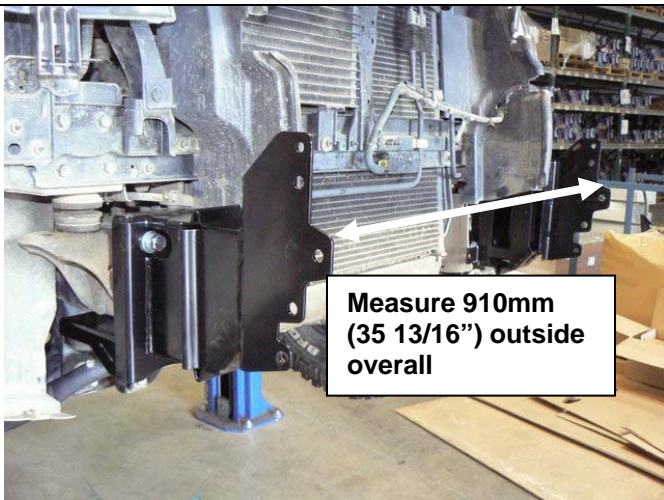

Measure 910mm (35 13/16") outside overall

38. Check the overall width of the mount brackets by measuring the distance inside the faces. The two inside vertical faces should be parallel to each other.

39. For reference, the ideal width is 910mm. If the width is over this or well under, adjust the brackets to achieve approximately this width then do all the bolts up to specified torque.

BULL BAR PREPARATION



40. Fit the buffers to either side of the bull bar using 6 x M6 flange nuts. Do not over tighten.
41. Fit M6 cage nuts to four holes in lower pan flange. The nut bodies are inside the bull bar



IF NOT FITTING A WINCH

42. Apply rubber mould to edge of winch hole cover panel and trim off excess.



43. Fit panel to top face on bull bar using 2 x M6 dome head stainless steel screws, flange nuts and flat washers.

NOTE: The flat washers are to be sandwiched between panel and top face of bull bar to stop the panel pulling down to form depression around screw heads.

WINCH FITMENT ONLY

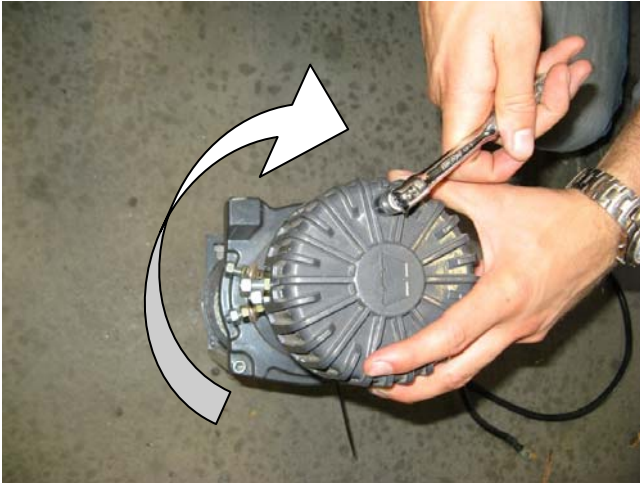

IF FITTING A WINCH

44. Rotate the winch motor 90 degrees as shown

NOTE: Follow the winch manufacturers instructions regards motor rotation and drainage requirements

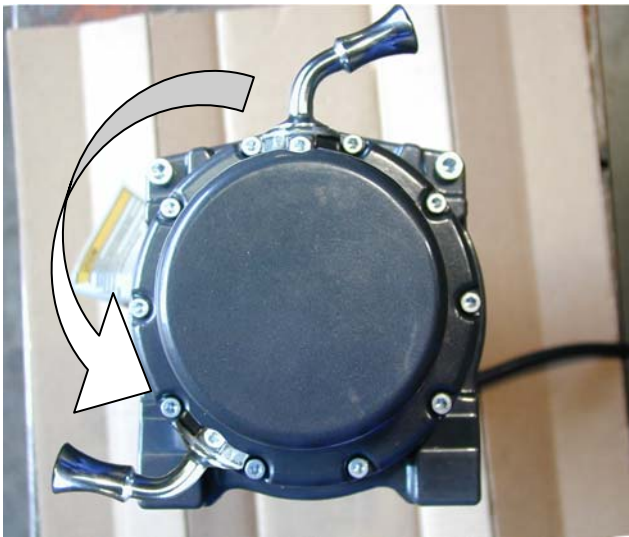

45. Remove the cap head screws retaining the gearbox to the winch drum. Carefully lift the gearbox a small amount (5 mm) and rotate 144 degrees counter clockwise (four hole spacings) and re-fit the cap screws . This places the winch handle in the correct orientation.

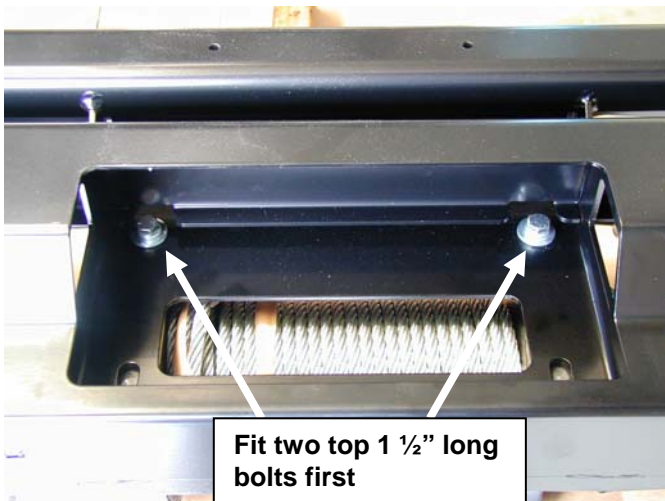

46. Lay the winch on a suitable flat surface and place the bull bar on top so that the wire rope will feed thru from the bottom.

47. Using the two 3/8" x 1 1/2" long bolts, M10 flat and spring washers, attach the bull bar to the winch through the top two bolt holes as shown.

WINCH FITMENT ONLY

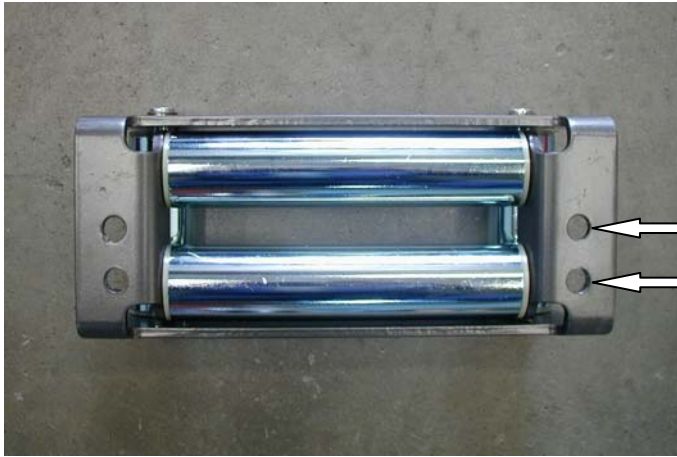

48. Using a 12mm drill bit, mark & drill two new holes in the roller fairlead 25mm below the original holes.

Drill the new hole 25mm below



Warning: Drilling operations can result in flying metal debris, safety glasses should be worn.



49. Remove the cir clips from the bottom of the vertical rollers of the fairlead and push the pin upwards. Push the vertical rollers inwards on the lower edges as shown and using two 3/8" x 1 3/4" bolts M10 flat and spring washers, attach the lower section of the roller fairlead to the bull bar and winch.
50. Replace the cir clips on the vertical rollers on both sides.



51. Insert the two rubber grommets into the top face of bull bar.

WINCH FITMENT ONLY



52. Attach the control box to the control box bracket as shown.
53. Fit the control box to the bull bar with two M8 x 25mm bolts, M8 flat washers and M8 flange nuts.

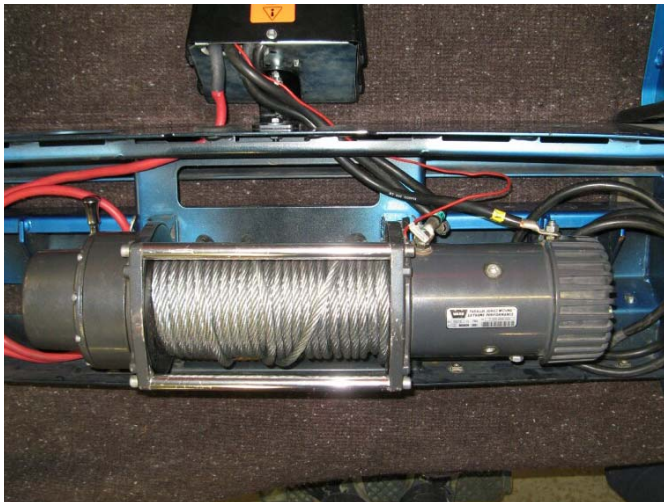

54. Run the cables through the rubber grommets and connect to the winch as per the wiring diagram supplied with the winch.
55. Using cable ties fix the cables securely and ensure they are well away from any moving, sharp or hot surfaces.

BULL BAR FITMENT TO VEHICLE

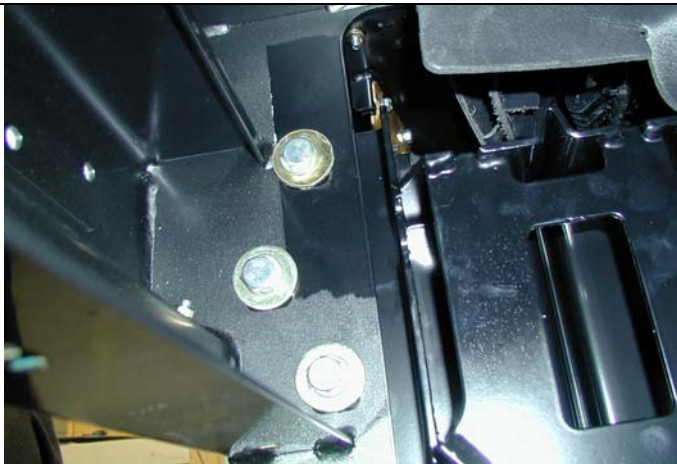

56. With assistance guide the bull bar into position on the vehicle. The uprights on the bull bar sit inside the impact absorber blades.
57. Bolt the bull bar into position using the M12 bolts, spring washer, large body washer and flange nuts 3 places each side as shown. Tighten the bolts firmly – but allow enough movement for the bull bar to be adjusted

BULL BAR FITMENT TO VEHICLE



**Need new photo
with 15mm gap**

58. Ensure the bull bar is sitting on the vehicle level and the gap between the bumper bar and the bull bar wing is parallel.

15 mm (5/8") GAP REQUIRED

59. If the bull bar is not centred on the vehicle, tap the mount brackets sideways with a soft hammer until the bar is central

60. Once happy with the position of the bull bar and the clearance gap is 15mm, tighten all the mount bolts to specified torque

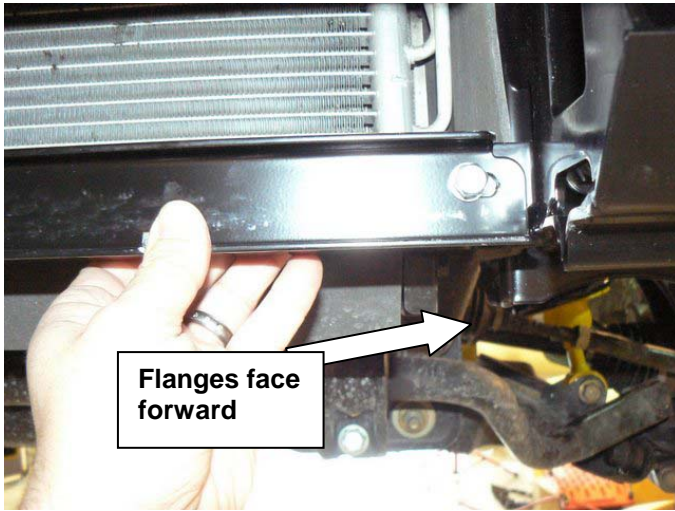

**Flanges face
forward**

61. The stone shield cross brace can now be fitted to the flange attached to the impact absorber using an M8 bolt, spring washer, flat washer and M8 flange nut set per side.

62. Tighten both sides.

63. Install the two M6 cage nuts (long leg) with the body of the nut facing upward.



64. Using an electric drill and a 10.0 mm drill bit, drill two pinning bolt holes through the bull bar upright each side using the holes in the mount bracket flanges as a guide. One hole is located in the lower lug of the mount face and one up above the welded nuts. Use access through the light surround opening for the top hole.



Warning: Drilling operations can result in flying metal debris, safety glasses should be worn.

BULL BAR FITMENT TO VEHICLE



65. Fit the pinning bolts to the bull bar in the drilled positions using 4 x M10 SEMS bolt and washer sets and M10 flange nuts.



66. Assemble and install combination light surrounds (p/n 3163015) as per instructions no. 3786421 supplied with surround kit. Note: Optional fog lamps can be installed at this point as per fitting instruction no. 3783315 supplied with fog lamp kit no. 6821201.

67. Wire the combination lamp to the vehicles indicator and clearance lamp wiring.

Caution: Cable tie all cables together and keep all cables clear of sharp edges and moving parts.

Wiring:

Green wire is Turn signal + (pos)

Red is running lamp + (pos)

Black is – (neg)



68. Refit the vehicle sump guard, leave the front bolts out at this stage

69. Attach the stone tray to the under side of the bull bar with the black M6 bolts, flat washers & spring washers. The back edge fits over the lip of the sump guard.

There are four bolts in the front edge and two in the back edge.

BULL BAR FITMENT TO VEHICLE



70. The licence plate can now be attached to the bull bar. Insert the two plastic square plugs supplied into the two square holes in the face of the bull bar.

71. If winch fitted, position the licence plate as shown fastening using lower holes. If winch not fitted use the top row of holes, licence plate is positioned lower and covers RFL opening in front of bull bar

72. Using the two dome head screws supplied screw into position firmly.



73. Trim the lower edge of the fender liner as shown



74. Push the outer edge of the liner forward past the wing return edge so that it snaps in against the wing brace as shown.

ONCE BAR IS FITTED:

- ◆ Ensure all bolts are tensioned correctly
- ◆ All wiring is clear of sharp edges or moving surfaces and secured properly
- ◆ Piping is secured well away from sharp or moving components
- ◆ Check operation of winch if fitted
- ◆ Check all wiring and turn signal lamps are functioning correctly

FITTED PRODUCT

