

# Installation Instructions

## 2051110

### Level of Difficulty

Easy

### Parts List

1	Driver / left running board*
1	Passenger / right running board*
2	Mounting bracket, front
2	Mounting bracket, middle
2	Mounting bracket, rear
2	Fishwire, M6
2	Carriage bolt, M6
2	Spacer plate, M6
2	Flat washer, M6
2	Lock washer, M6
2	Hex nut, M6
8	T-bolt plate, M10
8	Flat washer, M10
8	Lock washer, M10
8	Hex nut, M10
8	Plastic bolt retainer, M10
2	Spacer plate, 1/2"
2	Fishwire, 1/2"
2	Carriage bolt, 1/2"
2	Hex nut, 1/2"
2	Lock washer, 1/2"
2	Flat washer, 1/2"

\*Running boards sold separately

### Additional Hardware\*

12	Hex bolt, M8
12	Flat washer, M8
12	Lock washer, M8
12	Hex nut, M8

\*Running boards are supplied with additional hardware. Quantities listed are in addition to the standard supplied hardware.

### Tools Required

Ratchet	Level
Socket set	--

### Product Photo

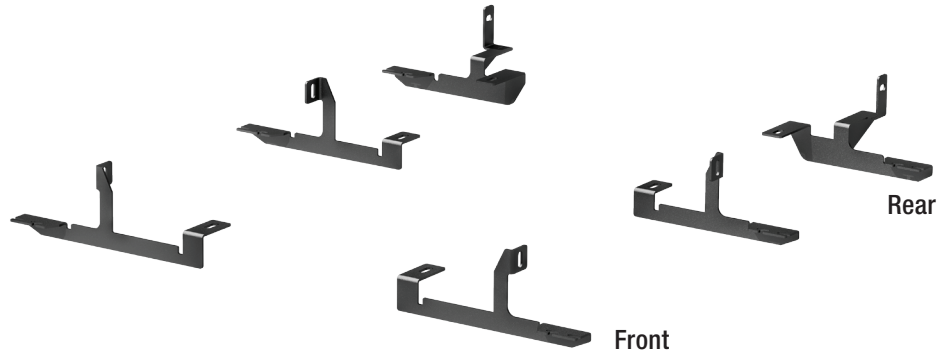

### AeroTread™ (not included)



### Torque Specifications

Metric			SAE		
	M6 bolt	3 ft-lbs.		1/4" bolt	3 ft-lbs.
M8 bolt	7 ft-lbs.	5/16" bolt	7 ft-lbs.		
M10 bolt	16 ft-lbs.	3/8" bolt	16 ft-lbs.		
M12 bolt	28 ft-lbs.	7/16" bolt	20 ft-lbs.		
--	--	1/2" bolt	28 ft-lbs.		

Use above torque setting unless otherwise noted

### Notes and Maintenance

Before you begin installation, read all instructions thoroughly.

Proper tools will improve the quality of installation and reduce the time required.

To protect the product, wax after installing. Regular waxing is recommended to add a protective layer over the finish. Do not use any type of polish or wax that may contain abrasives that could damage the finish.

For polished, gloss and other smooth finishes, polish may be used to clear small scratches and scuffs on the finish.

Mild automotive detergent may be used to clean the product. Do not use dish detergent, abrasive cleaners, abrasive pads, wire brushes or other similar products that may damage the finish.

Refer to the table to the left when securing hardware during the installation process to help prevent damage to the product or vehicle.

### Step 1

Starting on the driver side, locate the three mounting locations underneath the vehicle.

**Note:** Each bracket is specific to a mounting location. Reference page 1 product image for correct locations.



### Step 2

Locate the front mounting points and remove the rubber plugs.

Insert an M10 T-bolt plate into each opening. Slide a plastic bolt retainer over the threads of the bolts to hold the bolts in place.



### Step 3

Place the front driver-side bracket onto the vehicle and secure with two M10 hex nuts, lock washers and flat washers.

Snug the hardware, but do not fully tighten.



### Step 4

Locate the middle mounting points and remove the rubber plugs.

Insert an M10 T-bolt plate into side opening as shown. Slide a plastic bolt retainer over the threads of the bolt to hold the bolt in place.



### Step 5

Place the middle driver-side bracket onto the vehicle and secure with an M10 hex nut, lock washer and flat washer.

Once the bracket is in place, fishwire the rear mounting tab with M6 fishwire, carriage bolt and spacer plate.

With the bolt in place, secure with an M6 hex nut, lock washer and flat washer.

Snug the hardware, but do not fully tighten.



### Step 6

Locate the rear mounting points and remove the rubber plugs.

Insert an M10 T-bolt plate into the side opening as shown. Slide a plastic bolt retainer over the threads of the bolt to hold the bolt in place.

In second mounting location, fishwire a 1/2" carriage bolt and 1/2" spacer plate as shown.



### Step 7

Place the rear driver-side bracket onto the vehicle and secure the bolt plate with an M10 hex nut, lock washer and flat washer.

With the 1/2" bolt in place, secure with a 1/2" hex nut, lock washer and flat washer.

Snug the hardware, but do not fully tighten.



### Step 8

Remove the M8 nuts, lock washers and flat washers from the running board.

Place the running board onto the brackets and align the M8 bolts with the slots in the brackets on the vehicle.



### Step 9

Attach the running board to the brackets using six M8 bolts, lock washers, flat washers and hex nuts.

Snug the hardware, but do not fully tighten.

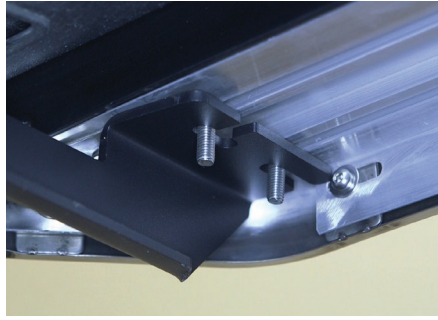

### Step 10

Adjust and level the running board, centering it between the front and rear wheel wells.

With the running board in position, it is recommended to tighten all brackets to the vehicle first, followed by the running board connections.



### Step 11

Repeat steps 1 through 9 on the passenger side of the vehicle.

Congratulations on the installation of your new ARIES AeroTread™ running boards.

With the running boards installed, periodic inspections should be performed to ensure all mounting hardware remains tight.

To protect your investment, see the 'Notes and Maintenance' section on the first page of this instruction manual.

