



P3066 INSTALLATION MANUAL

Parts List

1	Grille guard
1	Driver / left frame bracket
1	Passenger / right frame bracket
1	Driver / left top bracket
1	Passenger / right top bracket
1	LED support flange
2	Hex bolt, 8 - 1.25mm x 40mm
4	Hex bolt, 8 - 1.25mm x 30mm
4	Nylock nut, 8 - 1.25mm
4	Hex bolt, 10 - 1.5mm x 30mm
4	Nylock nut, 10 - 1.5mm
2	Double nut plate, 12 - 1.75mm
4	Hex bolt, 12 - 1.75mm x 35mm
2	Clip-on nuts, 8mm
4	Lock washer, 8mm
8	Flat washer, 8mm x 22mm OD x 2mm
8	Flat washer, 10mm x 24mm OD x 2.2mm
4	Lock washer, 12mm
4	Flat washer, 12mm x 32mm OD x 3mm

Level of Difficulty

Moderate

Product Image



Brackets and Hardware

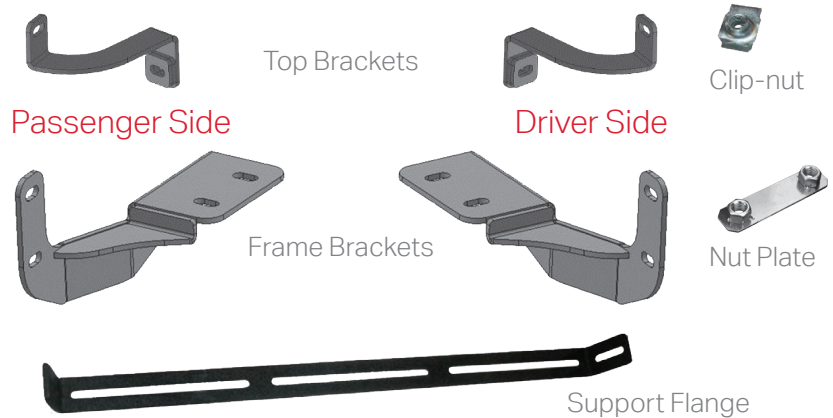

Notes and Maintenance

Remove all contents from the box and verify all parts are present

Before you begin installation, read all instructions thoroughly

Assistance is recommended for installation

Proper tools will improve the quality of installation and reduce the time required

Cutting is required on vehicles without tow hooks

It may be necessary to remove / relocate the front license plate and license plate bracket on models equipped with Ecoboost engine

Step 1A - For vehicles with factory tow hooks

Remove the driver-side tow hook and plastic trim between the tow hook and splash guard.

Note: Do not move the nut plate inside the frame. Plastic trim will not be reinstalled.

Select the driver-side frame mounting bracket. Insert the bracket between the tow hook and the frame. Reattach the tow hook(without trim), with the factory bolts. Snug the hardware, but do not fully tighten.

Repeat this process on the passenger side.



Step 1B - For vehicles without factory tow hooks

From behind the bumper, release the clips attaching the plastic bumper pads to the steel bumper. Temporarily remove the pads and license plate mounting bracket. Remove the air dam and plastic splash guard.

Note: Grille removed for clarity only. Removal of the grille is not required.

Insert one 12mm double nut plate into the end of the driver side of the frame. Line up the nut plate with the holes in the bottom of the frame and the driver-side frame mounting bracket.

Attach the bracket to the bottom of the frame and nut plate with the 12mm hex bolts, 12mm lock washers and 12mm flat washers. Snug the hardware, but do not fully tighten.

Repeat this process on the passenger side.

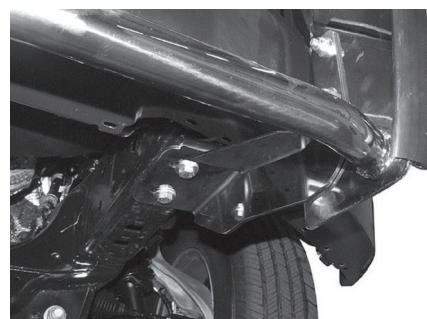
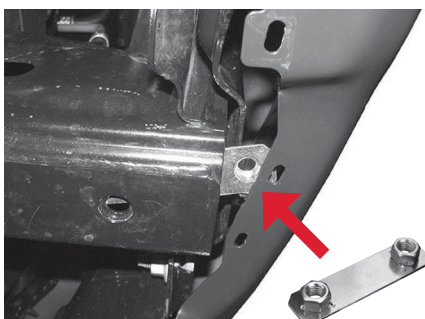
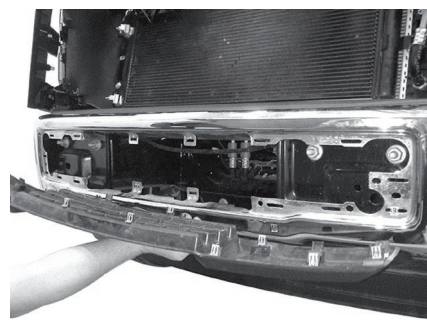

Step 2

From under and behind the bumper, locate the top of the driver side bumper bracket.

Locate the center bumper bolt attaching the top of the bracket to the back of the bumper. It may be necessary to temporarily release the clips and move the rubber cover to access the bumper bolts.

Remove the hex bolt from the top-center of the bumper bracket.

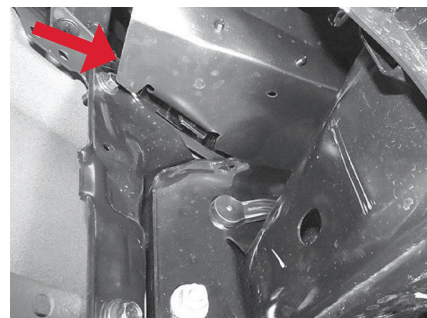
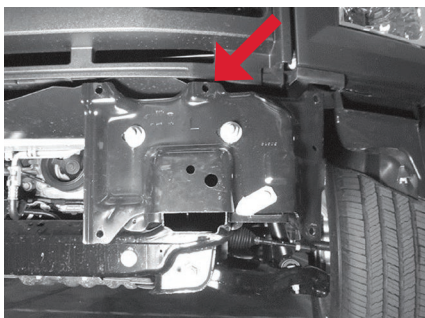

Step 3

Select the driver-side top bracket.

Insert the top bracket into the space between the top of the bumper and the bottom of the grille.

Attach the bracket to the bumper bracket with the included 8mm hex bolt, lock washer and flat washer. Snug the hardware, but do not fully tighten.

Repeat this process on the passenger side.

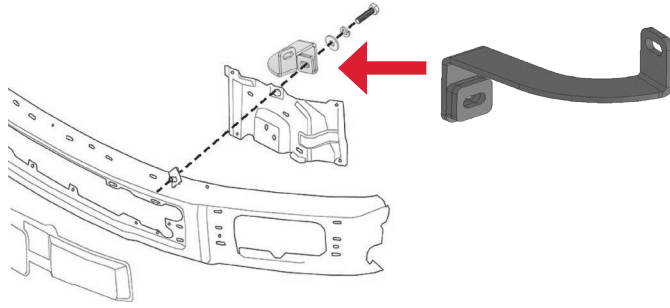

Step 4

Select an LED light (sold separately), mounting hardware and brackets. Attach the hardware to the support flange.

Note: LED manufacturers may have different mounting styles or brackets. Once the mounting options are determined, attach it to the support flange.



Step 5

With the LED light attached to the support flange, place the two 8mm nut clips into the slotted holes on either side of the support flange.

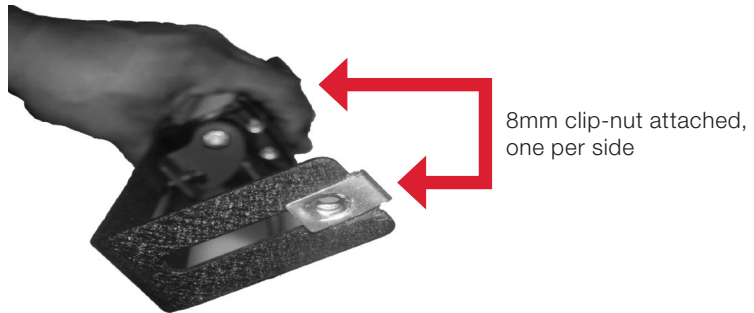

Step 6

Place the grille guard face down and set the support flange into the center flange of the grille guard.

Attach each side of the support flange to the inner brackets on the center flange with two 8mm hex bolts, two 8mm flat washers and two 8mm lock washers.

Snug the hardware, but do not fully tighten.

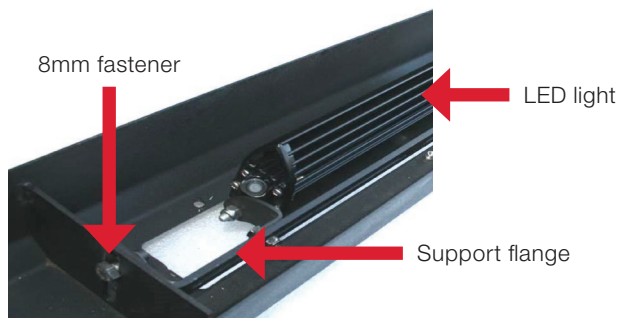

Step 7

With assistance, position the grille guard on the outside of the frame brackets.

Attach the grille guard to the brackets with four 10mm x 30mm hex bolts, eight 10mm flat washers and four 10mm nylock nuts.

Snug the hardware, but do not fully tighten.

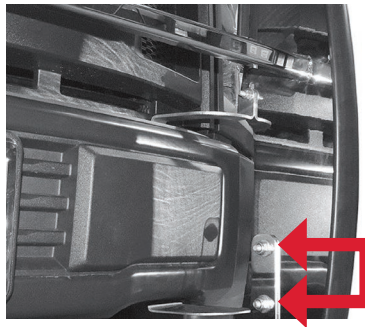

10mm fasteners

Step 8

Center the grille guard on the vehicle. Once properly adjusted, fully tighten the four 12mm hex bolts attaching the frame brackets to the bottom of the frame and / or tow hook.

For vehicles without tow hooks:

With the lower brackets secured to the frame, temporarily remove the grille guard. Hold the splash guard up to the base brackets and trace the trim locations. Use a sharp knife or cut wheel to remove the material, allowing the brackets to fit through the guard.

Reinstall the splash guard and remount the grille guard to the lower brackets.

Do not cut through front or back edge of splash guard



Step 9

Line up the driver-side top bracket with the hole in the upright on the grille guard.

Attach the bracket to the grille guard with one 8mm x 30mm hex bolt, two 8mm flat washers and one 8mm nylock nut.

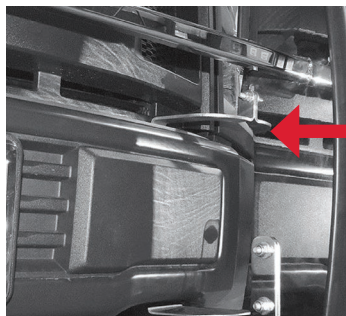

8mm fasteners

Step 10

Once the grille guard is aligned, tighten all hardware.

Remember to do periodic inspections to make sure that all hardware is secure and tight.

Congratulations on the installation of your brand new Aries Pro Series grille guard.

