



## **INSTALLATION INSTRUCTIONS**

2007-10 CHEVROLET SUBURBAN 1500 2/4WD

2007-10 GMC YUKON XL 1500 2/4WD

PART # 204004 / 204004-2

Read the instructions completely before you begin the installation. NOTE: Pictures are for reference only, actual brackets may be different. Installation is the same

### **PARTS LIST**

- |  |                               |
|--|-------------------------------|
| (2) SIDE TUBES WITH STEPS                                      | (4) 1/2" x 2" HEX HEAD BOLTS  |
| (2) FRONT MOUNT BRACKETS                                       | (4) 1/2" FLAT WASHERS         |
| (2) REAR MOUNT BRACKETS  | (4) 1/2" SPLIT LOCK WASHERS   |
| (2) CENTER MOUNT BRACES  | (2) 5/16" x 1" HEX HEAD BOLTS |
| (6) M12 – 1.75 x 120mm HEX HEAD BOLTS ( ONLY FOR 00-06 MODEL ) |                               |
| (4) 5/16" FLAT WASHERS   |                               |
| (2) 5/16" SPLIT LOCK WASHERS                                   |                               |

### **PROCEDURE**

1. Begin installation by working on driver side of the vehicle (see Figures 1.1 – 1.4).
2. From underneath truck, loosen and remove body mount bolts that run upward through mounts into floorboard. Attach and secure Front Mount Bracket to underside of vehicles front body mount (see Figure 1.2) with (1) M12 – 1.75 x 120mm bolt ( For 07 Model, use the factory bolt on the vehicle), (1) 1/2" split lock washer, and (1) 1/2" flat washer. Hand Tighten.
3. Attach and secure Rear Mount Bracket to underside of vehicles rear body mount as shown in Figure 1.4, in same manner as the front. Repeat for Center Brace,(see Figure 1.3).
4. Attach Side Tube to Front and Rear Brackets using (1) 1/2" x 2" bolt, (1) 1/2" lock washer and (1) 1/2" flat washer for each bracket, and hand tighten. Fasten Center Brace to Side Tube using (1) 5/16" x 1" bolt,(1)5/16" Flat washer and (2) 5/16" flat washer. Adjust Side Tube so that it is level and centered, and tighten all bolts to complete the driver-side assembly.
5. Repeat process for passenger side of vehicle to complete installation.

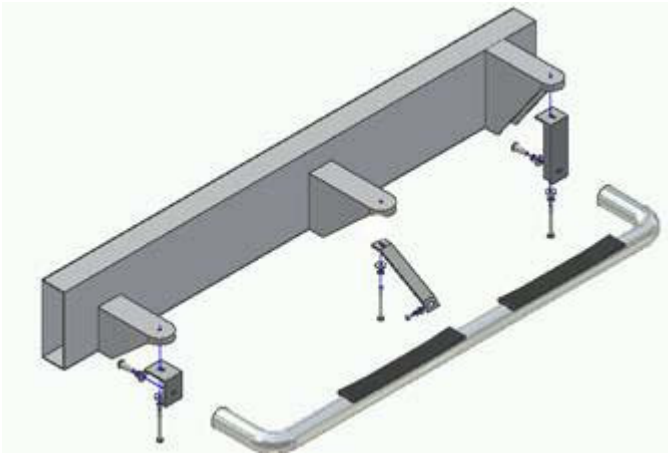

Figure 1.1 – Driver-Side Full Assembly View

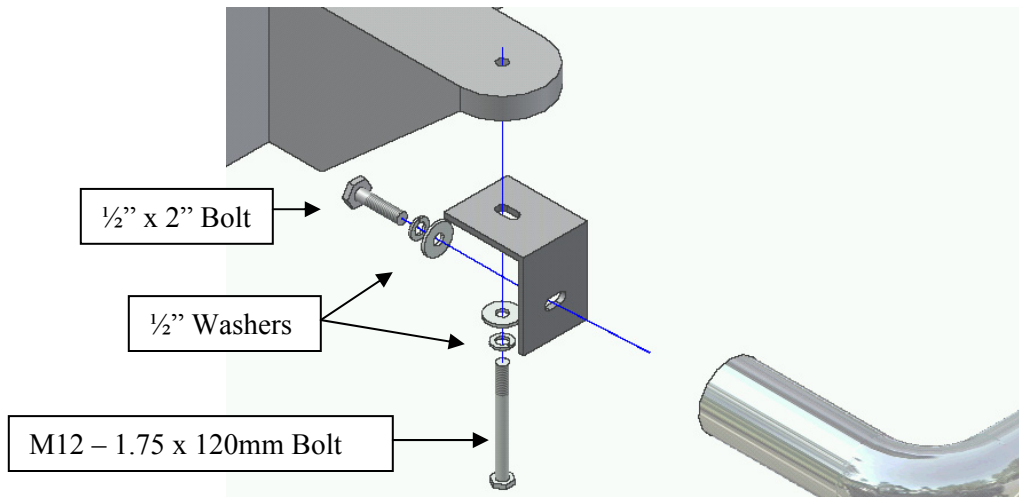

Figure 1.2 – Front Bracket

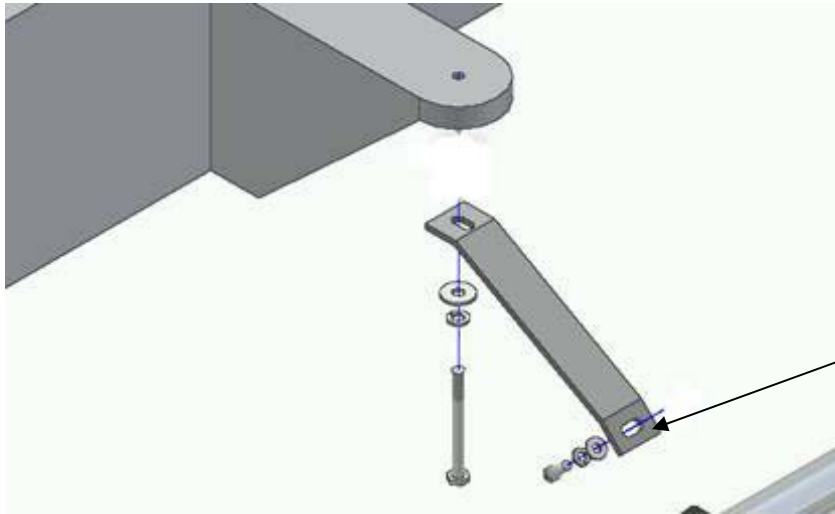

Figure 1.3 – Center Brace

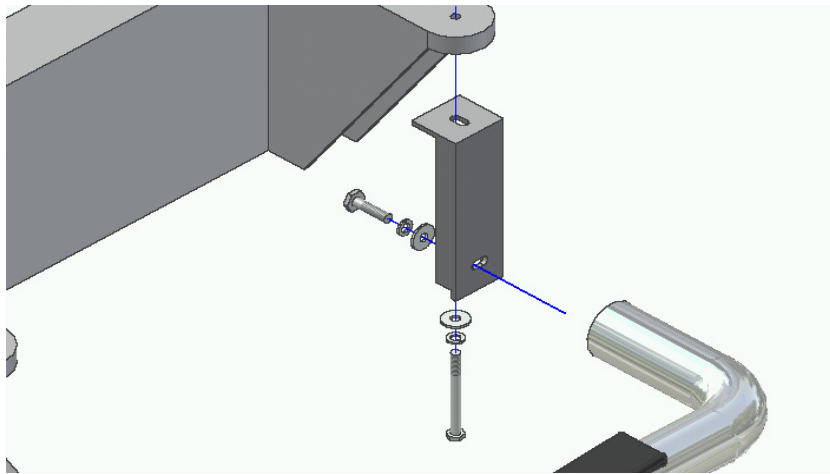

Figure 1.4 – Rear Bracket

## INSTALLTION ALERT

General Motors has made changes to their late model 2010 and 2012 Chevrolet Silverado and GMC Sierra Light Duty and Heavy Duty Trucks and these changes affect the installation of our Side Bars.

Currently, all Side Bars manufactured for GM trucks use the factory body mount bolts to attach the bars and brackets to the truck. In years past, GM used a fixed nut that was welded in place to the chassis of the truck. Starting late 2010, GM has now gone to a loose nut that is surrounded by a "Cage Nut" which has two tabs on either side of the nut to keep it from loosening. Along with this cage nut, GM is also using Heavy Duty Loc-tite on the Body Mount Bolts for added protection.

Due to this change, Aries is recommending **EXTREME CARE** when removing the factory body mount bolts from these trucks. **Loosen and re-tighten all body mount bolts by hand! DO NOT use Impact Tools of any kind!** If bolts become increasingly tight as you are loosening them you may need to retighten & loosen the bolt several times to clear the loc-tite from the threads Failure to follow this instruction could cause the body mount bolts to seize and the tabs of the 'Cage Nut' to bend allowing the nut to spin freely inside Chassis floor board!

Most of clients have been installing the existing side bar applications on these new trucks with no issues, but please be sure to follow our recommendation to prevent any installation issues.

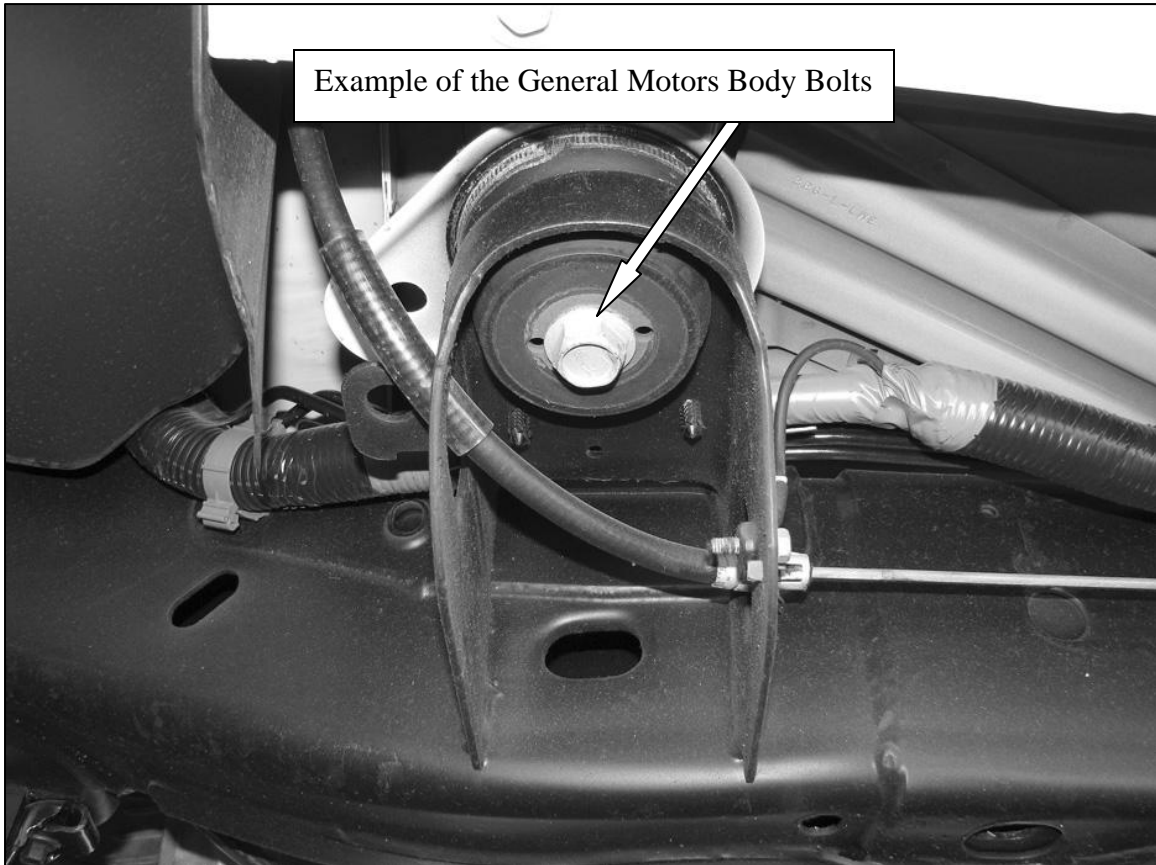

[Learn more about other running boards and step bars by Aries on our website.](#)