

# ARTEC INDUSTRIES JL NIGHTHAWK FRONT SWAY BAR SKID

Thank you for your purchase of our front sway bar skid. If you have any questions that are not answered in these instructions, please feel free to contact us directly and we will be happy to help you.

ITEM NO.	PART NUMBER	DESCRIPTION	QTY.
1	JL5304-1	JL Front Bumper Skid	1
2	HW0055	3/8"-16 Zinc-Plated Steel Rivet Nut	2
3	HW0101	3/8 x 1 1/2 Buffon Head Cap Screw Alloy Steel Zinc Plated	6
4	HW0019	3/8"-16 Nylock Insert Hex Nut Clear Zinc	4
5	TC0011	Rivet Nut Tool Kit	1
6	HW0059	3/8" Flat Washer Type 1 Yellow Zinc	4

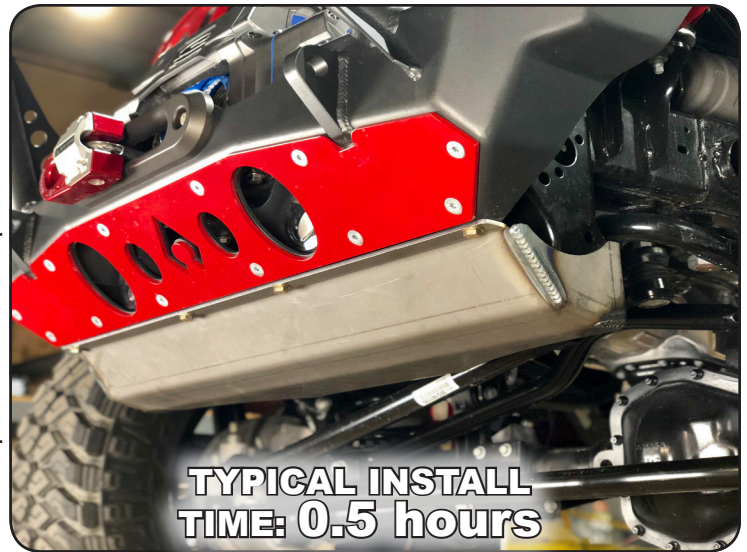
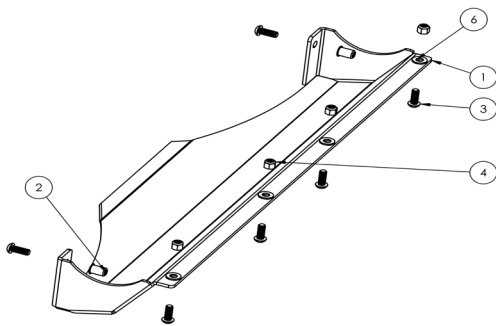

## REQUIRED TOOLS

- 9/16" Wrench
- 31/64" drill bit
- 7/32" Allen

**STEP 1.** Unpack contents of shipment. Make sure that all of the parts required are included with your kit. If any items are missing, and packaging is damaged, report it to the shipping company driver, **KEEP ALL ORIGINAL PACKAGING & contact us.**

**STEP 2.** First start by parking the vehicle on level ground and apply the parking brake. With your NightHawk front bumper installed, start by locating the rear mounting holes for the bracket. These holes will need to be drilled out with a 31/64". Next install the rivet nuts using the provided rivet nut tool. Ensure that you don't over tighten the rivet nut when using the rivet nut tool. We recommend using hand tools and not using air tools during this step.

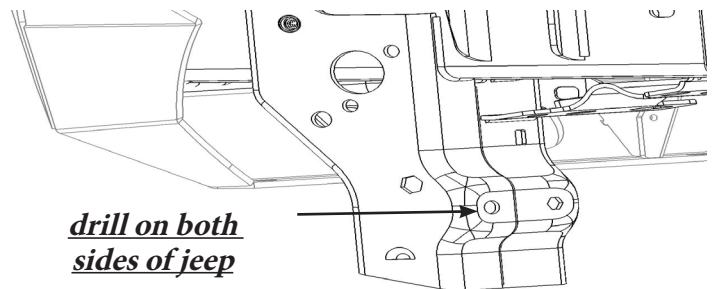

**STEP 3.** Next hold the skid up and loosely install all the hardware. Once all the hardware is installed perform final tightening. If you have not already coated the skid with paint or powder coat we recommend doing this now the fitment is verified.

**NOTE: THIS KIT INVOLVES VEHICLE MODIFICATION AND MECHANICAL SKILLS. IF YOU ARE NOT CONFIDENT IN YOUR SKILLS, CONTACT A PROFESSIONAL INSTALLER.**