

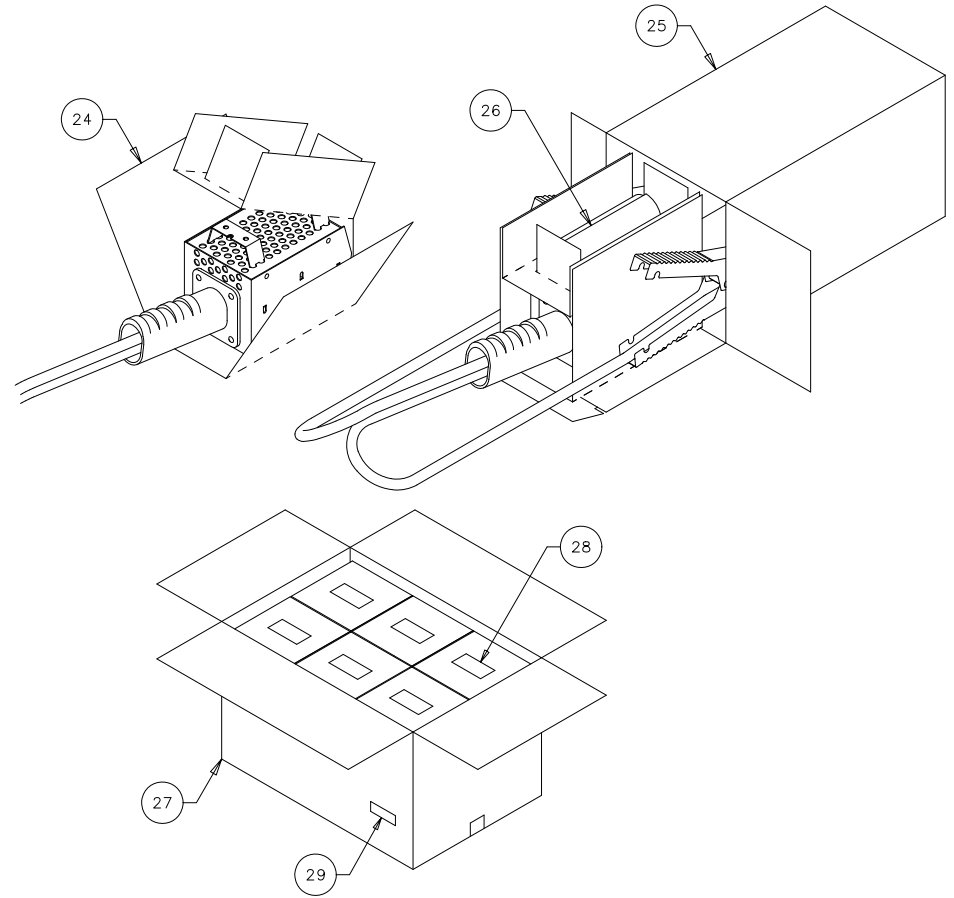

**ASSOCIATED**

ITEM	PART NO.	DESCRIPTION	DWG. NO.	QTY
24	030-0688	CRTN,PACKING	B4155	1
25	030-0689	CRTN,UNIT	D5149	1
26	027-0791	MANUAL, 6030DV	W2276	1
27	030-0307	CRTN,MASTER	D4488	.167
28	151-0240	LABEL, UPC 6030DV UNIT 099684002400	N/D	1
29	151-0241	LABEL, UPC 6030DV MASTERPACK 099684002417	N/D	.167

REV	REVISION	ECN	BY	APPR	DATE
	SEE SHEET 1 FOR REVISIONS				

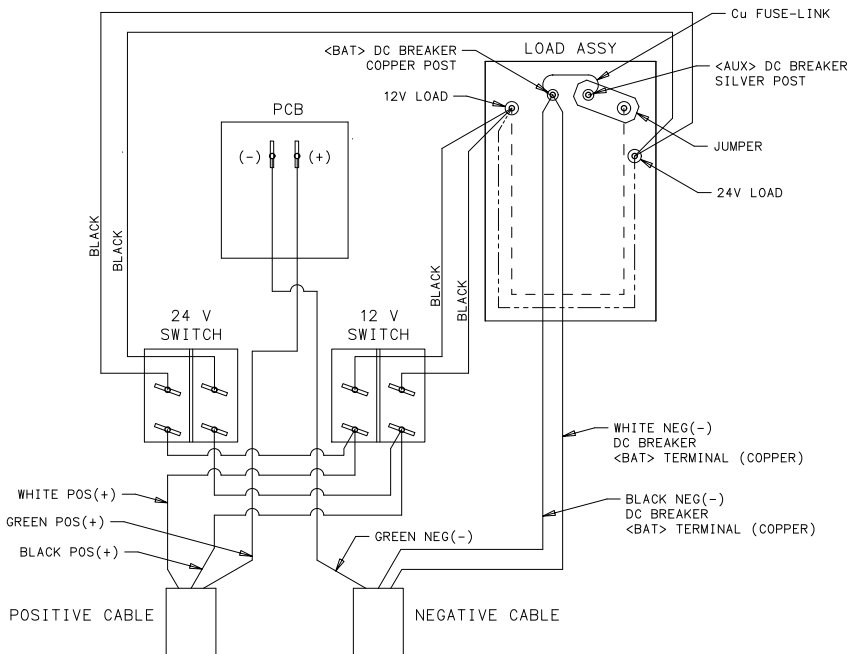

- NOTES:
14. MASTER CARTON (#27) IS TAPED ON BOTTOM & TOP.
  15. UNIT CARTONS (#25) MUST BE INSERTED INTO MASTER CARTON WITH TOP FLAP OF CARTON FACING UP. ALL TEXT SHOULD FACE THE SAME DIRECTION.
  16. ALL MASTER CARTONS WILL CONTAIN 6 UNITS.
  17. MASTER CARTONS WILL BE STAMPED USING BLACK INK ON ANY TWO ADJACENT SIDES, PER CARTON MARKING SPEC 006-0087.

ASSOCIATED EQUIPMENT CORP. ST. LOUIS, MISSOURI 63115

B4164 DWG NO.	DIMENSIONS ARE IN INCHES UNLESS OTHERWISE SPECIFIED		TITLE	
	UNLESS OTHERWISE SPECIFIED TOLERANCES ARE		ASSEMBLY, HAND HELD TESTER 6030DV	
	FRACTIONAL	:1/64	DRAWN BY	GJ. BEQARI
	DECIMAL	.XX :.01 .XXX :.005	DATE	09/29/04
ANGULAR	:.5°	CHECKED BY	DATE	SCALE NTS
DO NOT SCALE DRAWING		PART NO.	6030DV	PROJECT NO.
		DRAWING NO.	B4164	REV.
				SHEET 4 OF 4