



MODEL 6036B BATTERY TESTER OPERATOR'S MANUAL

IMPORTANT SAFETY INSTRUCTIONS

SAVE THESE INSTRUCTIONS

This manual contains important safety and operating instructions for the battery tester you have purchased. You may need to refer to these instructions at a later date.

CAUTION: The electrolyte in automotive batteries is sulfuric acid, which is capable of causing severe damage to skin, eyes, and clothing. When contact is made with the electrolyte, follow these instructions:

- a) Eyes: Force open and flood with cool running water at least for 10 minutes, then see a doctor. Never use eye drops or other medication before seeing a doctor.
- b) Remove contaminated clothing and flood skin for at least 10 minutes with clear, cool water.

While batteries are being charged or tested, an explosive gas mixture forms inside each cell. Some of this gas escapes through the vent holes in the filler caps and accumulates in the battery compartment. Sparks or flames igniting this gas mixture will burn back through the vent hole and explode inside the battery cell. Such an explosion is dangerous and may spray electrolyte which would spray onto anything in the vicinity.

TO PREVENT EXPLOSIONS:

- a) Use well ventilated areas for charging and testing batteries.
- b) Add distilled water in each cell until battery acid reaches level specified by battery manufacturer. This helps purge excessive gas from cells. Do not over-fill. Follow manufacturer's instructions.
- c) Allow no smoking, sparks or open flames near batteries being charged, tested or batteries recently charged and to be tested.

WARNING - RISK OF EXPLOSIVE GASES.

- a) Working in vicinity of lead-acid battery is dangerous. Batteries generate explosive gases during normal battery operation. For this reason, it is of utmost importance to read the instructions exactly each time you use this battery tester.
- b) To reduce the risk of battery explosions, follow these instructions and those published by battery manufacturer and manufacturer of any equipment you intend to use. Pay attention to the marking on these products and on the engine.
- c) Do not break live electrical circuits at the terminals of batteries because a spark may occur at that point causing an explosion. Always turn battery charger clamps from the battery terminals.

PERSONAL PRECAUTIONS:

- a) Wear complete protection and avoid touching eyes while working near battery.
- b) For acid contact on skin or clothing, remove clothing and wash skin immediately with soap and water. For acid in eye, immediately flood eye with running water and seek medical attention immediately. Never use eye drops or other medication before seeing a doctor.
- c) **NEVER** smoke or allow a spark or flame in the vicinity of battery or engine.
- d) Be extra cautious to reduce risk of dropping a metal tool onto a battery. The tool may spark or short-circuit the battery or other electrical parts which may cause an explosion.
- e) Remove personal metal items such as rings, bracelets, necklaces, and watches when working with a lead-acid battery. A lead-acid battery can produce a spark or the like to metal, and cause severe burn.
- f) Spilled acid: Neutralize with a solution of baking soda (1 pound per gallon of cold water) or household ammonia (1 pint per gallon of cold water)

UNPACKING AND UNLOCKING THE UNIT

1. To remove the unit from the carton, grasp the side handles in the packing and pull both the packing and the unit out of the carton. Remove the internal packing from the unit and return it to the carton. Set the carton and internal packing aside for future use.
2. Hold onto the knob to keep the shaft from spinning after it is unlocked. Loosen the set screw in the locking collar with the 3/32 hex wrench provided. DO NOT remove the set screw from the locking collar. Allow the shaft to back out slowly until it stops. (Locking down the carbon stack helps to prevent the carbon disk and ceramic tubes from breaking during shipping, or anytime the unit needs to be transported.)

NOTE: When shipping or transporting the unit, be sure to lock the shaft down by turning the knob all the way down and tightening the the locking collar set screw with the 3/32 hex wrench provided.

ATTACHING THE 6036B TO

If you have also purchased the optional two wheel utility cart model

1. Set the 6036B on top of the cart with the front of the unit mounting plate with the threaded inserts in the bottom of the
2. Insert the spade bolt through the hole in the mounting plate

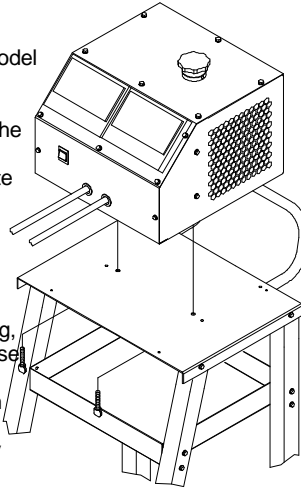

PREPARING TO TEST

- a) When necessary to remove battery from vehicle for testing, accessories in the vehicle are turned off, so as not to cause
- b) Clean battery terminals. Be careful to keep corrosion from
- c) Determine the cold cranking amps (CCA) rating of battery

TESTER LOCATION

- a) Locate tester as far away from battery as DC cables permit.
- b) Never allow battery acid to drip on tester or other items when handling a hydrometer, reading specific gravity or filling a battery.
- c) Do not set a battery on top of the tester.
- d) Position cables to reduce risk of danger by hood, door or moving engine parts.
- e) Stay clear of fan blades, belts, pulleys, and other parts that can cause personal injuries.
- f) Do not block air passaging through the tester.

CONNECTIONS AND PRECAUTIONS

- a) Connect and disconnect DC output clamps only after setting fan switch to "Automatic" position, and the LOAD CONTROL knob is counter-clockwise (CCV
- b) When attaching clamps to battery posts, twist or rock clamp back and forth several times to make a good connection. This tends to prevent the clamps from sparking.

NOTE: Either when receiving the unit new or when the unit has been sitting around awhile. The carbon stacks in the unit will collect moisture from the air and need to be pre-loaded, by turning the knob to a 100 amps and holding the knob for 5 to 10 seconds and releasing the knob (Do this on a good battery might be in the carbon stacks and prevents the carbons from cracking during normal operation. **Note:** If a lot of water or steam come out of the unit, d out.

OPERATING INSTRUCTIONS

1. Visually inspect batteries for obvious damage. Do not test a battery if post are loose, case is cracked or fluid level is below the top of the plates. With "mai instructions for checking water level. Do not test a frozen battery.
2. Be sure Voltmeter and Ammeter pointers are zeroed. Zero meters by adjusting screw on face of meter until meter points to zero.
3. See connection precautions before connecting or disconnecting clamp prior to test.
4. Depress FAN switch to "Automatic" and the fan will automatically turn on as the LOAD CONTROL on top of tester is turned clockwise, and automatically g clockwise.
5. Connect RED clamp to POSITIVE (POS, +, P) battery post and BLACK clamp to NEGATIVE (NEG, -, N) battery post.

NOTE: Depress FAN switch to "Manual" and the fan will run for as long as the tester is connected to a battery. **DO NOT CONNECT OR DISCONNECT**

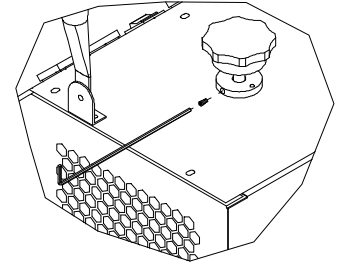

OPTIONAL 6038 UTILITY CART

6038 the two pieces are assembled as follows.

facing away from the handle. Align the two holes in t tester.

and thread the spade bolt into the insert as shown.

always remove ground terminal first. Make sure all an arc.

coming in contact with eyes.

by referring to car owner's manual or label on battery

WHILE FAN IS RUNNING, OR SWITCH IS IN "MANUAL" POSITION. To safely remove clamps depress the FAN switch to "Automatic" and KNOB counter-clockwise as far as possible. Fan will automatically be OFF and then the clamps may safely be removed from battery.

6. DETERMINE STATE OF CHARGE OF BATTERY

- a) Adjust LOAD CONTROL knob clockwise (CW) to 100 amps for 3 seconds. Adjust LOAD CONTROL knob counter-clockwise until the meter reads zero.
- b) Results:
 - 1. Pointer in green zone - proceed to LOAD TESTER.
 - 2. Pointer in red zone to left of green zone - battery is too low to test. Recharge & repeat procedure.
- c) Green band indicates a battery that is at least 75% charged.

7. LOAD TEST

- a) Figure the value of one-half of Cold Cranking Amps (CCA) rating of battery to be tested.
- b) Adjust "LOAD CONTROL" knob to the one-half of the battery's cold cranking amperage (CCA) rating using AMPERES LOAD meter as a reference. Hold amperage will probably change due to resistance changes in the cables, carbons and the battery. Readjust the LOAD CONTROL during this 15 seconds interval of 15 seconds and with the load on, read the battery's voltage on the volt scale. TURN THE LOAD CONTROL KNOB COUNTER-CLOCKWISE AS FAR AS POSSIBLE.
- c) The voltage reading obtained from a battery changes in relation to the temperature of the battery and also in relation to the amperage being drawn from the battery. The chart here and on the face of the tester gives the minimum voltage that should be obtained for the test procedure given. i.e.: The outside temperature is 60 degrees F. The minimum voltage for a battery is 9.5 at 60 degrees F. When at the end of the 15 second test you find that the battery's voltage is equal to or greater than 9.5, the battery is good. When it is less than 9.5, the battery is defective.

In some cases a six volt battery is to be tested. To do this simply divide the minimum volts of the chart by two to obtain the voltage reference to be used.

When smoke is emitted from any cell of the battery, the battery is defective regardless of the test indications

BATTERY TEMPERATURE COMPENSATION 15 SECOND LOAD TEST								
°C	21	16	10	4	-1	-7	-12	-18
°F	70	60	50	40	30	20	10	0
MIN. VOLTS	9.6	9.5	9.4	9.3	9.1	8.9	8.7	8.5

8. STRESS TEST:

- a) To determine if a battery is adequate for an application, a stress test may be applied to a battery. Determine the maximum current draw, minimum acceptable voltage, and time which the battery is to be installed.
- b) Run a load test at the determined current and time and check that the battery voltage is above the minimum voltage.

APPLICATION DATA:

ALTERNATOR TEST: Be sure that the battery in the car, test is good. Start engine with tester connected to the battery. The charging voltage of the alternator should be in the green zone. If the pointer is in the red zone to the left of the green zone, the voltage is too low to fully charge the battery. If the pointer is in the red zone to the right of the green zone, the voltage is too high. **NOTE:** In very cold weather, the alternator may read above 14.8 VDC. Check owner's service manual.

STARTER CURRENT TEST: Connect tester to battery. Be sure battery is fully charged. Ground the ignition, by removing the coil cable from the distributor cap wire to prevent arcing of high-voltage spark that could cause a fire, someone getting shocked, or damage to the ignition system. (On GM car with HEI ignition, ground the terminal on the distributor.) Turn ignition switch on and allow starter to run for 5 seconds. Read the voltage on the VOLT scale while cranking. With car circuit disconnected, adjust LOAD CONTROL knob to give VOLTMETER reading the same as measured while cranking engine. Read Amps on ammeter and the reading is the starter current.

VOLTMETER: used as a voltmeter to problems on any 6 or 12 voltages on volt scale.

NOTE: A static charge on the meter face, will be off zero. For the correct, this charge Spray "Static Guard" meter or wipe with a soap and water.

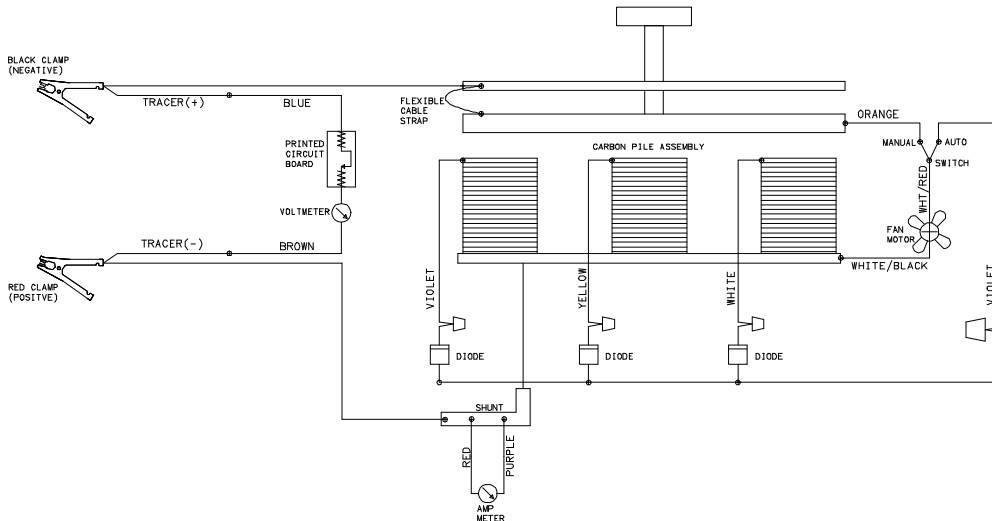

The tester may be used to troubleshoot electrical problems on a 12 volt vehicle. Read the voltage on the volt scale.

A static charge may build-up on the meter face causing the needle to read incorrectly. This charge must be neutralized by spraying with a soap and water solution or wiping with a damp cloth.

WIRING

DIAGRAM

REPLACEMENT PARTS

AMMETER	610333
VOLTMETER	610334
SHUNT ASSEMBLY	610335
BRACKET & NUT ASSY.	610337
TOP PLATE ASSY.	610338
CARBON STACK W/CERAMIC TUBE	610871
CERAMIC TUBES	610872

Parts may be purchased from your local authorized service depot listed in the Service Procedure Manual supplied with your products.

If you elect to order parts from the factory, you may do so by mail or by phone. Orders received that are under the minimum will not be processed. Taxes and freight are extra and are not considered to be part of the dollar value of the order. We **DO NOT** have a C.O.D. policy. Cashier checks, Money order, Master Card, or Visa are acceptable. If you use a Master or Visa Card, send only the number and the expiration date. **DO NOT SEND THE CARD.**