



MODEL:

**7856**

PRODUCT TYPE:

**AIR COOLING TESTER**



## WARNING



Study, understand and follow all instructions provided with this product. Read these instructions carefully before installing, operating, servicing or repairing this tool. Keep these instructions in a safe accessible place.

### INTENDED USE OF THE TOOL

The 7856 Air Cooling Tester is designed to use shop air to pressurize and test cooling systems and caps to the manufacturer's suggested levels.

**DO NOT OVER-PRESSURIZE YOUR COOLING SYSTEM.**

Do not use this tool outside of the designed intent. Never modify the tool for any other purpose or use.



## WARNING



### Caution: To help prevent personal injury

- Normal use of this product is likely to expose the user to dust and/or microscopic particles containing chemicals known to the State of California to cause cancer, birth defects or other reproductive harm. Always wear appropriate safety equipment and clothing when using this product. Study, understand and follow all instructions provided with this product. Failure to read and follow all warnings and operating instructions may result in damages and serious injury or death.
- Always wear ANSI approved goggles when using this product. (Users and By standers).
- Never use this tool for any application other than for which it was designed.
- Only use accessories designed for this tool.
- Never alter or modify this tool in any way.
- Improper operation and/or maintenance of the tool, modification of the tool, or use of the tool with accessories not designed for it could result in serious injury or death.
- Always select the correct accessories of the correct size and design for the job that you are attempting to perform.
- Always work in a clean, safe, well-lit, organized and adequately equipped area.
- Do not begin repairs without assurance that vehicle is in secure position, and will not move during repair.



**Astro Pneumatic  
Tool Company**

### Before Use

When unpacking, check the parts diagram and part number listing on page 2 to make sure all parts are included. If any parts are missing or damaged, please call your distributor.

### PRODUCT INFORMATION:

- Regulates shop air pressure to test and locate cooling system leaks, test caps, or speed up the coolant draining process
- Quick connector works on nearly all brands of cooling system testing caps and adapters
- Gauge displays the common pressure levels for different cooling systems and regulates up to a max of 30 psi to prevent damage

### SPECIFICATIONS:

Air Inlet : 1/4" NPT

Sugg. Press. In : 90 psi

Air Outlet : 30 psi max

Hose Length : 23.6"

## AIR COOLING TESTER



MADE IN TAIWAN

**DO NOT DISCARD – GIVE TO USER**

## INSTRUCTIONS

1. • Install an air fitting into bottom of tool and connect tool to airline.
  - Locate the pressure limit for your intended cooling system. Information can often be found on radiator cap, next to coolant tank/radiator, and/or in car repair manual.
  - Connect universal coupler at end of tool's hose to most any common cooling system tester cap or radiator cap adapter.
2. • Test radiator cap or cooling system by securing your supplied adapter (now connected onto the tool) to the radiator, coolant overflow tank or radiator cap of your application.
  - Turn the red lever to open the ball valve on tool.
  - Increase pressure to the system by slowly adjusting the black regulator valve dial, watching the pressure gauge on tool.
  - Adjust the regulator up to the max level shown on the gauge that matches your pressure system requirements. **DO NOT OVER-PRESSURIZE CAP OR SYSTEM, STOP AT THE RED LINE ON GAUGE FOR THE MANUFACTURER'S RECCOMENDED LEVEL**
  - Close the red lever on the ball valve and leave system pressured for a predetermined amount of time. Check after this time if pressure has dropped, indicating a system leakage.
3. • If a leak is suspected, open the red lever again and provide sustained pressure to the system.
  - With constant pressure on the system, you may now be able to trace the ongoing leak and inspect pressurized hoses for damage and excessive wear.
  - Before removing cap, depressurize system by pressing and holding the pressure release button near the end of the hose to vent pressure from system.
4. • If draining a cooling system from the vehicle's coolant drain location, this tool can be used with the ball valve open to provide some moderate pressure to the system - expediting the drain process.

## PARTS BREAKDOWN

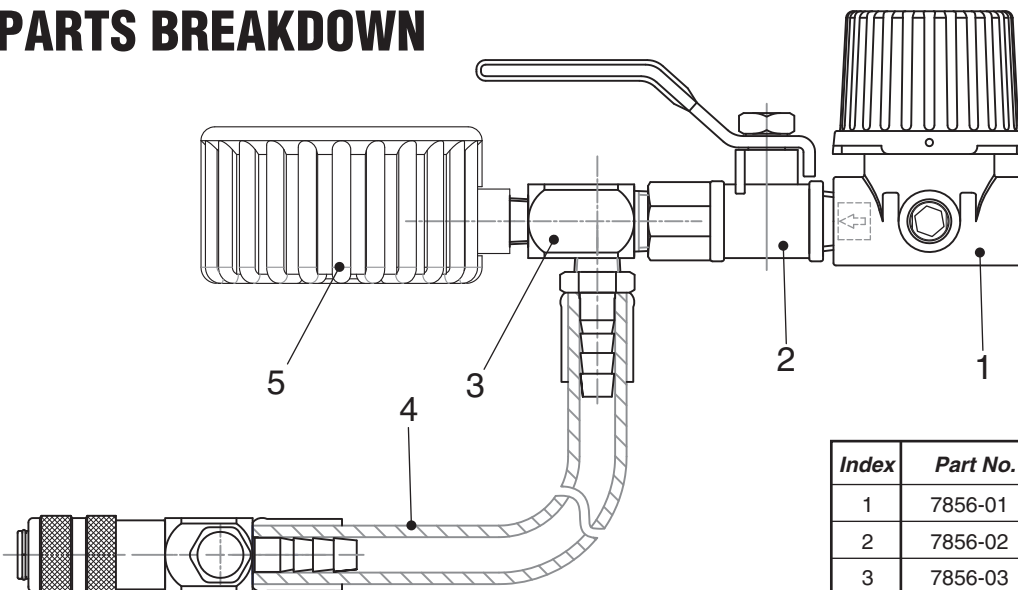

### Parts List

<i>Index</i>	<i>Part No.</i>	<i>Description</i>	<i>Qty</i>
1	7856-01	Regulator	1
2	7856-02	Ball Valve W/ Lever	1
3	7856-03	1/4" NPT Connector	1
4	7856-04	PVC Braid Hose	1
5	7856-05	2" Cooling Pressure Gauge	1