

**PARTS BREAKDOWN**

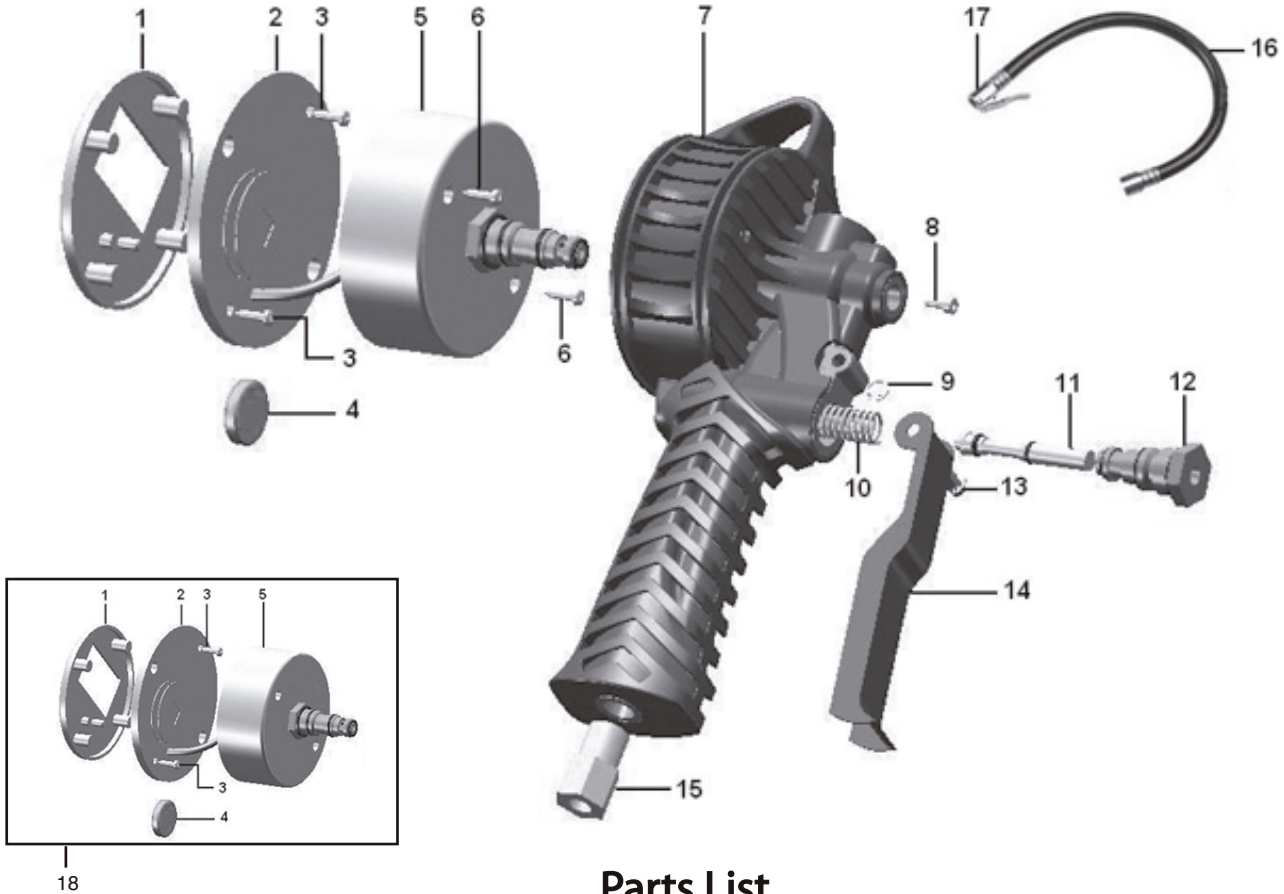

**Parts List**

<i>Index No.</i>	<i>Part No.</i>	<i>Description</i>	<i>Qty</i>
1	3018-01*	Front Cover	1
2	3018-02*	PCB Board Assembly	1
3	3018-03	Ø 2.6 x 6.0 Screw	2
4	3018-04	CR2450 Battery	1
5	3018-05*	Sensor Valve Assembly	1
6	3018-06	Ø 3.5 x 14 Screw	2
7	3018-07	Main Body	1
8	3018-08	Hex Screw Ø 3.5 x 8	1
9	3018-09	Circlip Ø 3.5	1
10	3018-10	Pagoda Spring 0.85 x 7.0 / 8.0 x 18.5 x 7	1
11	3018-11	Valve Assembly	1
12	3018-12	Valve Base Assembly	1
13	3018-13	Lever Pin	1
14	3018-14	Lever	1
15	3018-15	Air Inlet	1
16	3018-16	Rubber Hose Assembly	1
17	3018-17	Air Chuck	1
18	3018-18	Digital Gauge Assembly	1

Items marked with an (\*) are not sold individually