



Model: ATD-7500

Capacity: 3 Ton

Operating Instructions & Parts Manual

ATD 3-Ton Jack Pack

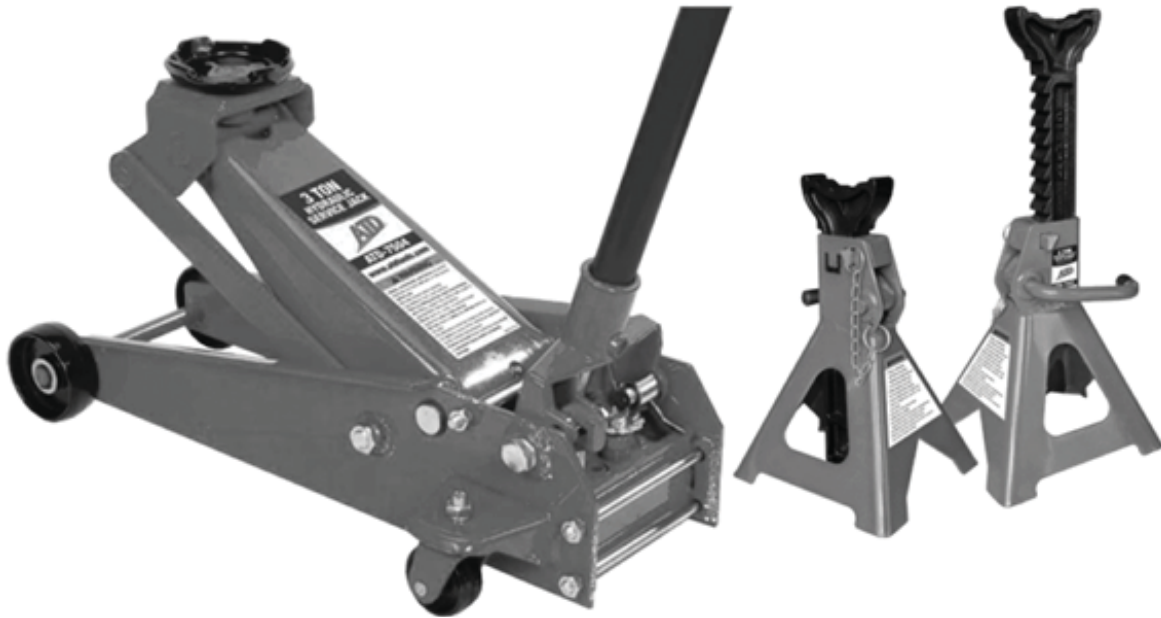

Service Jack Model Number: ATD-7504

Capacity	Min. Height	Max Height	Jack Size (L x W x H)	Saddle Diameter	Net Weight
3 Ton	5-3/8"	19-1/2"	26-3/4" x 13-3/8" x 7-1/4"	4-5/16"	78 LB

Jack Stands Model Number: ATD-7443

Capacity	Min. Height	Max Height	Saddle Size	Base (L x W)	Net Weight
3 Ton	11-13/16"	17-5/16"	3-1/2" x 1"	7-11/16" x 6-15/16"	15 LB

Contents:

- Page: 1. Specifications
 2. Safety & Warning Information
 3. 4. & 5. Setup, Operation & Preventive Maintenance
 6. Inspection, Storage & Troubleshooting
 7. Exploded View & Replaceable Part Numbers
 8. Warranty Information

⚠ WARNING ⚠

WARNING: This product may contain chemicals, including lead, known to the State of California to cause cancer, birth defects or other reproductive harm. *Wash hands after handling.*



Model: ATD-7500

Capacity: 3 Ton

SAFETY & WARNING INFORMATION



This is the safety notification symbol. This symbol will notify you of any potential injury hazards. Please follow all instructions that follow this symbol to avoid possible injuries or death.



Indicates a hazardous situation. If proper steps are not followed, death or serious injury could result.



IMPORTANT: READ ALL INSTRUCTIONS BEFORE USE

Before operating this device, be sure to read all content within this manual, ensuring that you understand the operating procedures, maintenance requirements and all safety warnings.

The owner and/or operator shall have an understanding of the product, its operating characteristics, and safety operating instructions before operating this device. Safety information shall be emphasized and understood. If the operator is not fluent in English, the product and safety instructions shall be read to and discussed with the operator in the operator's native language by the purchaser/owner or his designee, making sure that the operator comprehends their contents.



ACTIONS TO HELP PREVENT DANGEROUS SITUATIONS

- Study, understand, and follow all instructions before operating this device.
- Do not exceed the rated capacity stated.
- Use only on hard level surfaces.
- This jack is to be used as a lifting device only. Immediately after lifting, support the vehicle with appropriate means.
- Do not move or dolly the vehicle while it is on the jack.
- Lift only on areas of the vehicle as specified by the vehicle manufacturer.
- No alterations shall be made to this product.
- **Jack Stands** are designed to support stated capacity. Stands should only be used to support partial loads that consist of one end of a vehicle. Always use as a matched pair to support one end of a vehicle only.
- **Never** use jack stands to support **both ends** or **one side** of a vehicle.
- Use only **one (1) pair** of stands per vehicle.
- Rated capacity is **per pair only**.
- **Rated capacity of this pair is 6000 lbs.**
- Failure to heed these markings may result in serious personal injury and/or property damage.



Model: ATD-7500

Capacity: 3 Ton

SETUP, OPERATION & PREVENTIVE MAINTENANCE



SETUP

- Prior to each use, visual inspection (See Pg. 6) shall be made to the device by checking for abnormal conditions, such as cracked welds, leaks, and damaged, loose, or missing parts.
- Consult the vehicle owner's manual to determine the location of lift points.
- Be sure to set the vehicle in park with the emergency brake on and wheels securely chocked.
- Be sure that the vehicle and the jack are on a hard, level surface.



ASSEMBLY

Service Jack

- Assemble the upper section of the two piece handle into the lower section, line up the holes, insert and tighten the screw.
- Insert the bottom end of handle into handle fork and securely tighten the bolt and washer. Ensure the handle can turn freely.

Jack Stands

- Tools Required: Hammer & Punch (not included with set)
- Insert the ratchet bar into the base frame with the ratchet portion of the bar aligned with the locking pawl.
- Move the ratchet bar to its lowest position by raising the locking handle, disengaging the stopper and slowly lowering the ratchet bar downward into the base.
- Collar lock is achieved by simply pressing the press tab (See Pg. 5) inward using the hammer and punch. This will prevent accidental loss of the ratchet bar.



LIFTING

- Turn the handle/release valve clockwise to the closed position. Do not over tighten.
- Position the jack under the specified lift point.
- Begin lifting by pumping the handle up and down.
- Immediately after lifting, insert safety pins into the appropriately rated jack stands and support the vehicle. NEVER support the vehicle with only the jack.
- Turn the handle/release valve slowly counterclockwise to lower the vehicle onto jack stands.



Model: ATD-7500

Capacity: 3 Ton

SETUP, OPERATION & PREVENTIVE MAINTENANCE (Cont.)



LOWERING

- Turn the handle/release valve clockwise to the closed position. Do not over tighten.
- Pump the handle up and down to lift vehicle off jack stands.
- Remove the jack stands and safety pins. DO NOT get under or let anyone get under the vehicle while lowering.
- Turn the handle/release valve slowly counterclockwise to lower the vehicle onto the ground.



SERVICE JACK MAINTENANCE

NOTICE: Use high grade hydraulic oil only. Never use brake fluid, motor oil, transmission fluid, turbine oil or any other fluids. ISO-VG22 or equivalent hydraulic oil is recommended.

Check and Refill Oil

- With the jack in the fully lowered, level position, if unit cover is provided, remove unit cover, then remove oil filler plug.
- Proper oil level should be just covering inner cylinder as seen from the oil filler plug hole.
- Do not overfill. Always fill with new, clean hydraulic jack oil as recommended above.
- Reinstall oil filler plug, then reinstall unit cover.

Lubrication and Cleaning

- Periodically clean and lubricate all moving parts and pivot points.

Air Venting Procedures

- With the jack in the fully lowered position, release valve open, remove oil filler plug.
- Pump the handle rapidly several times. Reinstall oil filler plug.
- Turn the handle/release valve clockwise to the closed position.
- Pump the handle until the lift arm reaches maximum height and continue to pump several times to remove trapped air in the system.
- Turn the handle/release valve counterclockwise in one full turn and lower lift arm to the lowest position. Use force on saddle if necessary.
- Carefully and slowly loosen oil filler plug to release pressurized air.
- Repeat above steps until trapped air is completely vented.



Model: ATD-7500

Capacity: 3 Ton

SETUP, OPERATION & PREVENTIVE MAINTENANCE (Cont.)

JACK STANDS

Inspect each stand before use. Ensure all parts move freely. Only apply grease to the locking handle pivot point of this product and ensure all excess grease is wiped away before stand is used. If rust appears, sand away the rust area and cover with appropriate utility paint. Please note that there are no replacement parts available for this product.

DAMAGED EQUIPMENT

Any service jack that appears to be damaged in any way, is found to be worn, or operates abnormally **SHALL BE REMOVED FROM SERVICE UNTIL REPAIRED**. It is recommended that necessary repairs be made by a manufacturer's or supplier's authorized repair facility if repairs are permitted by the manufacturer or supplier.



Any jack stand that appears to be damaged, is found to be worn, or operates abnormally in any way will be removed from service and destroyed immediately.

Alterations

Because of potential hazards associated with this type of equipment, no alterations shall be made to the product.

Attachments and Adapters

Only attachments and/or adapters supplied by the manufacturer shall be used.

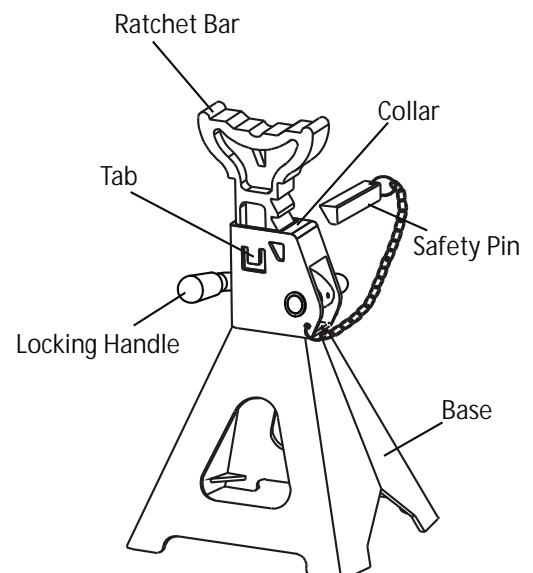
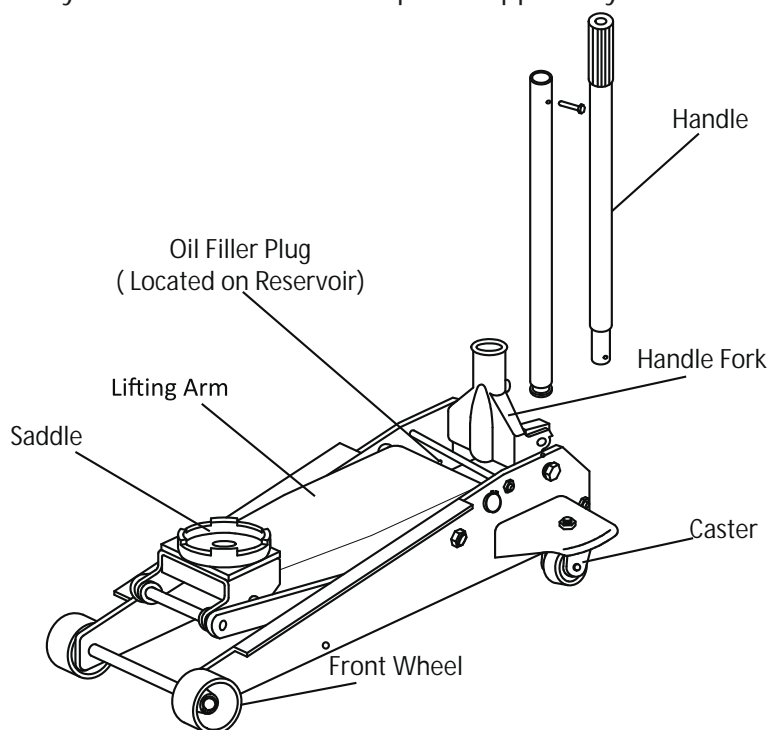



Model: ATD-7500

Capacity: 3 Ton

INSPECTION, STORAGE & TROUBLESHOOTING



INSPECTION

- Visual inspection shall be made before each use of the device by checking for abnormal conditions, such as cracked welds, leaks, and damaged, loose, or missing parts.
- Other inspections shall be made per product operating instructions.
- These devices shall be inspected immediately if the device is believed to have been subjected to an abnormal load or shock. It is recommended that this inspection be made by a manufacturer's or supplier's authorized repair facility.
- Owners and/or operators should be aware that repair of this service jack may require specialized knowledge and facilities. It is recommended that an annual inspection of the product be made by a manufacturer's or supplier's authorized repair facility and that any defective parts, decals, or safety labels or signs be replaced with manufacturer's or supplier's specified parts.



STORAGE

The service jack and jack stands should be stored in a dry location on a level surface.



TROUBLESHOOTING

Symptom	Possible Causes	Solution
Jack will not lift the load.	<ol style="list-style-type: none"> 1. Release valve not tightly closed. 2. Low oil level. 3. Defective or worn internal parts. 4. Load exceeds maximum allowance. 	<ol style="list-style-type: none"> 1. Tighten release valve. 2. Check and add oil. Follow "Check and Refill Oil" instructions on Pg.4. 3. Discontinue use and contact a local repair center. 4. Use a higher capacity jack.
Jack will not hold the load.	<ol style="list-style-type: none"> 1. Release valve not tightly closed. 2. Power unit malfunction. 	<ol style="list-style-type: none"> 1. Tighten release valve. 2. Discontinue use and contact a local repair center.
Jack will not descend to minimum height, or will not remain in lowered position.	<ol style="list-style-type: none"> 1. Air trapped in system. 2. Reservoir oil overfilled. 	<ol style="list-style-type: none"> 1. Vent air out of system. Follow "Air Venting Procedures" above. 2. Check and ensure proper oil level. Follow "Check and Refill Oil" instruction on Pg.4.
Jack will not lift to max height.	<ol style="list-style-type: none"> 1. Low oil level. 	<ol style="list-style-type: none"> 1. Check and ensure proper oil level. Follow "Check and Refill Oil" instructions above.
Jack will not function properly after tried solution.	<ol style="list-style-type: none"> 1. Internal malfunction or structural damage. 	<ol style="list-style-type: none"> 1. Stop usage and contact an authorized repair center.



Model: ATD-7500

Capacity: 3 Ton

EXPLODED VIEW & REPLACEABLE PART NUMBERS

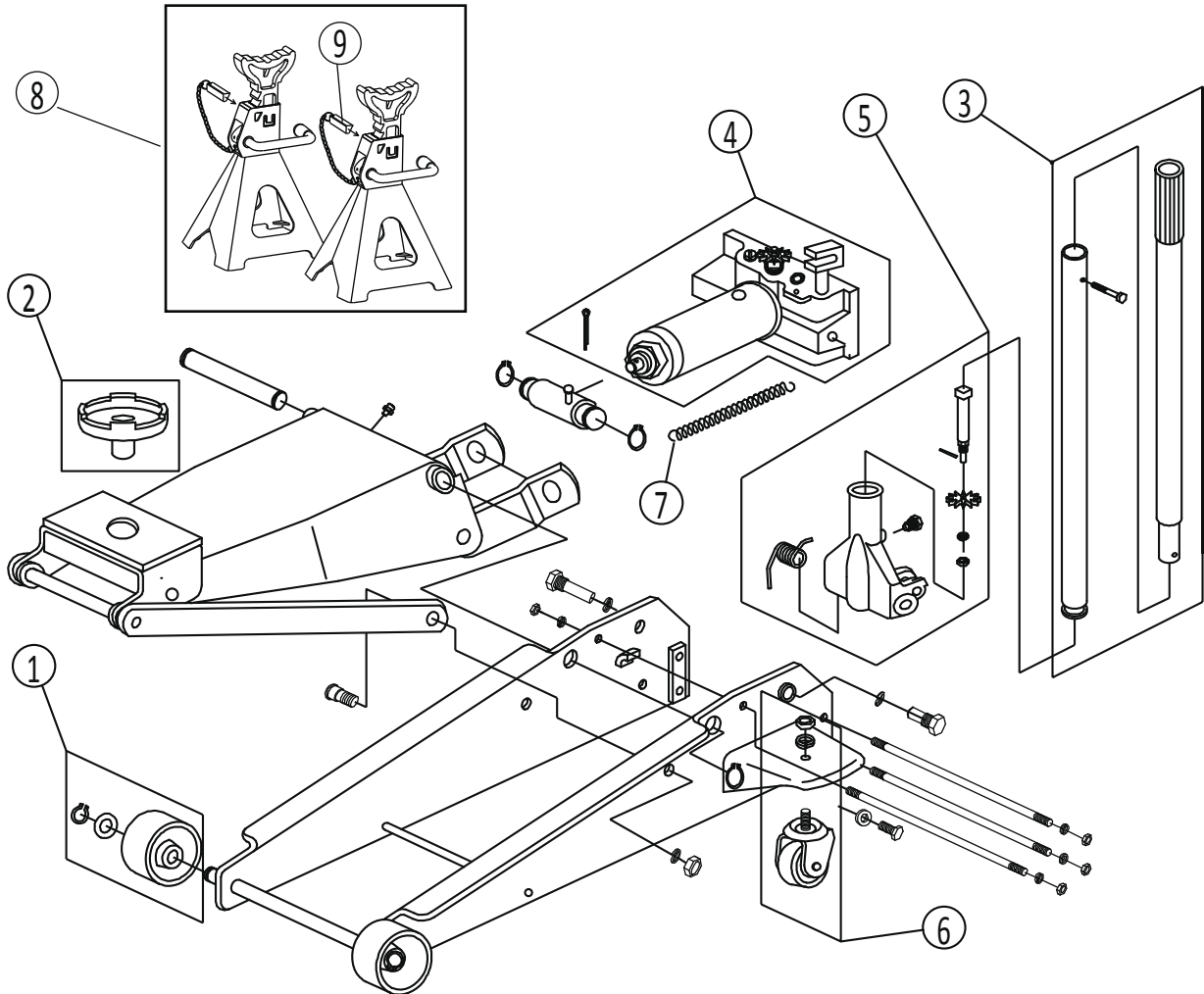

Item	Part Number*	Description	Qty
1	LYD3D-100	Front wheel assembly	2
2	LYD3D.5B	Saddle	1
3	LYD3D-101	Two Piece Handle	1
4	LYD3C.6	Power Unit	1
5	LYD3D-102	Handle Fork Assembly	1
6	LYD3D-103	Rear Caster Assembly	2
7	LYD2-9	Return Spring	1
8	ATD-7443	3 Ton Jack Stands W/ Safety Pin	2
9	ZJ3H-PJ-5	Safety Pin With Chain	2
N/A	ATD7500-L	Product Label	1
N/A	LYD3F-100	Oil Filler Plug (rubber)	1

* Items not identified by part number are not available for replacement.

Discover other car jacks on our website.