

**FOR PANEL OR IN-DASH MOUNTING ALL MECHANICAL PRESSURE GAUGES**

**WARNING:** Do Not overtighten aluminum fittings. This will damage fittings.

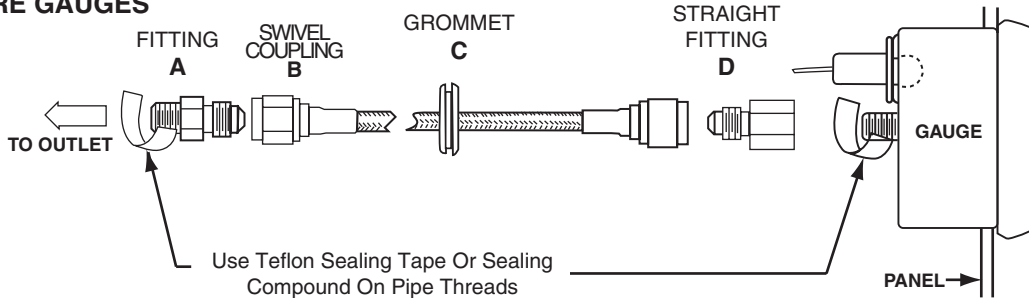

**FOR CUP MOUNTING MECHANICAL PRESSURE GAUGES— CUP MODELS 3201 & 3202**

USE RIGHT-ANGLE FITTING E

HOLE IN CUP MAY NEED ENLARGING

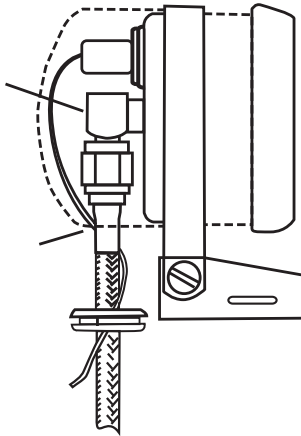

**FOR CUP MOUNTING LIQUID-FILLED MECHANICAL PRESSURE GAUGES— CUP MODELS 5201 & 5202**

ADAPTOR FITTING F

RIGHT-ANGLE FITTING E

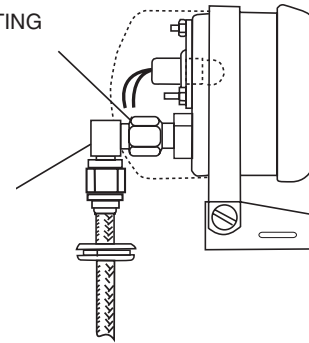

1. Attach fitting (A) to vehicle outlet using teflon sealing tape. (Tape not included)
2. Attach pressure hose swivel coupling (B) to fitting (A).
3. If routing through the firewall, drill a 3/4" diameter hole and use rubber grommet (C). Slit grommet to fit over hose.
4. Attach fitting (D), (E), or (F) to gauge using teflon sealing tape or sealing compound on pipe threads.  
(D) : Straight fitting for PANEL mounting.  
(E) : Right-angle fitting for MOUNTING CUP installation (Competition Gauges).  
(E & F) : Right-angle fitting and adaptor fitting (Pro-Comp liquid filled gauges).
5. Attach pressure hose to fitting (D) or (E) on gauge.
6. Start engine and check for leaks. Tighten if necessary.

**IMPORTANT:** When tightening, be sure to not overtighten aluminum fittings.  
To remove pressure hose, always loosen swivel coupling first.