

FULL SWEEP ELECTRIC TEMPERATURE GAUGE WITH WARNING INDICATOR, PEAK RECALL & PRO CONTROL



2650-1330-00 Rev. A

USE TEFLON SEALING TAPE OR SEALING COMPOUND ON PIPE THREADS

SEE PAGE 2 FOR WIRING INSTRUCTIONS

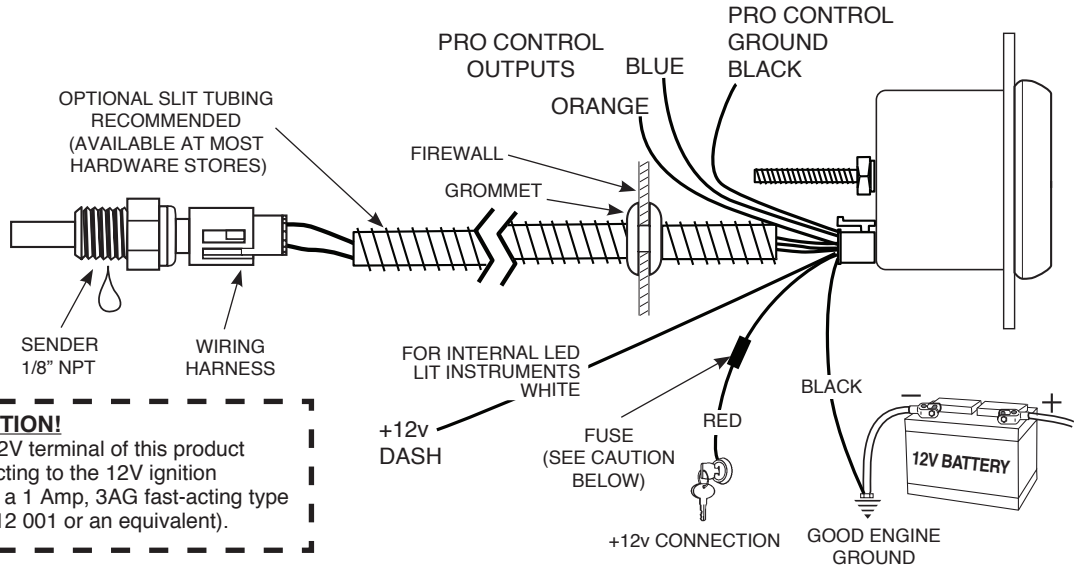

CAUTION!
As a safety precaution, the +12V terminal of this product should be fused before connecting to the 12V ignition switch. We recommend using a 1 Amp, 3AG fast-acting type cartridge fuse (Littlefuse® # 312 001 or an equivalent).

Installation

NOTE: Some late model vehicles use electronic sensors in their pressure and temperature senders for engine control functions. Before removing the original sender, we recommend that you contact your automotive dealer to be sure no critical functions will be disrupted.

1. Check that you have all parts required for installation, and the engine is cool.
2. Disconnect the negative (-) battery cable.
3. Gauge mounts in a 2-1/16" hole. Use supplied brackets and nuts to secure gauge to dash.
4. Drill 1" diameter hole where wires pass through sheet metal (such as firewall and install rubber grommet provided. (Grommet will require slit.)
5. Connect the white wire to dash lighting or switchable 12v light source, the red wire to switched +12V source and the black wire to ground. (see diagram for details)
6. Install temperature sender.
 - A. Water Temp: Install temperature sender.
Note: Included sender is 1/8" NPT. For 3/8" NPT or 1/2" NPT ports, use included adapter.
 - B. Trans. Temp: Hole may have to be drilled, and adapter nut welded or brazed in pan. Be sure there is adequate internal clearance for nut and sender.
7. Cut end of included dielectric grease packet, and squeeze grease into connector of temperature sender prior to connecting harness. (Important: This will protect connection from dirt and moisture.)
8. Connect red wire to switched +12V source and the black wire to ground. (see diagram for details)
9. Reconnect negative (-) battery cable.

NOTE: Test all fittings and connections for leaks. If any leaks are detected, determine the cause of the leak and repair. Do not operate vehicle if any leaks are detected.

Caution: LUBRIPLATE® DS-ES is a non-hazardous substance. However, it is recommended to wash hands thoroughly after use.

NOTE: Do not remove factory temp sender to install temp sender. If no location found, a hose adapter can be used.

NOTE: When the ignition is off the pointer may not always rest at zero.

Power-Up

The pointer will move backward to the stop pin and then display actual temperature. This procedure is an auto-calibration function and is performed on every power-up. While this test is being performed, the gauge may make a clicking sound. This is normal.

Peak Recall

Press and hold the PEAK button to recall the highest temperature reading since the memory was last cleared. To clear the memory, press and hold the PEAK button, and while still holding the PEAK button, press the WARN button. The pointer will move to the stop pin to indicate that the memory has been cleared. Release the PEAK and WARN buttons to resume normal operation. The peak recall point is retained when power is removed from the gauge.

Warning Indicator

On gauges with full dial warning, the "warning indicator" and "warning light" refers to the full dial backlighting. When the warning features are active, the full dial will illuminate red or flash red when appropriate.

In addition, gauges with full dial warning will flash red when the pointer is 10% beyond the warning set point.

Pro Control High Warning Set Point with Indicator

To adjust the high warning set point, momentarily press and release the WARN button. The warning light will begin to flash and the pointer will move to the previous high warning set point signifying that warning set mode has been selected. Once in set mode, press the WARN button to move the pointer down, or press the PEAK button to move the pointer up. Three seconds after the last button press, the warning light will stop blinking and the pointer will return to the current temperature reading. The warning set points are retained when power is removed from the gauge. The Pro Control high set point is also the warning indicator set point.

Pro Control Low Warning Set Point

To adjust the low warning set point, press and hold the WARN button, and while still holding the WARN button, press the PEAK button. The warning light will begin to flash and the pointer will move to the previous low warning set point signifying that warning set mode has been selected. Once in set mode, press the WARN button to move the pointer down, or press the PEAK button to move the pointer up. Three seconds after the last button press, the warning light will stop blinking and the pointer will return to the current temperature reading. The warning set points are retained when power is removed from the gauge.

Pro Control

The Pro Control feature activates a switched ground output at a user defined set point. Pro Control can be used to switch on a relay to activate ignition kill, cooling fans, lamps, alarms, etc.

The set points define three regions on the gauge dial, the region below the low set point, between the set points, and above the high set point.



PRO CONTROL RELAY DIAGRAM

POINTER REGION	LOW SET POINT			HIGH SET POINT			WARNING INDICATOR
	PRO CONTROL LOW OUTPUT (#1)	NORMALLY OPEN CONTACT	NORMALLY CLOSED CONTACT	PRO CONTROL HIGH OUTPUT (#2)	NORMALLY OPEN CONTACT	NORMALLY CLOSED CONTACT	
A	Active (ON)	CLOSED (ON)	OPEN (OFF)	OFF	OPEN (OFF)	CLOSED (ON)	OFF
B	OFF	OPEN (OFF)	CLOSED (ON)	OFF	OPEN (OFF)	CLOSED (ON)	OFF
C	OFF	OPEN (OFF)	CLOSED (ON)	Active (ON)	CLOSED (ON)	OPEN (OFF)	ON

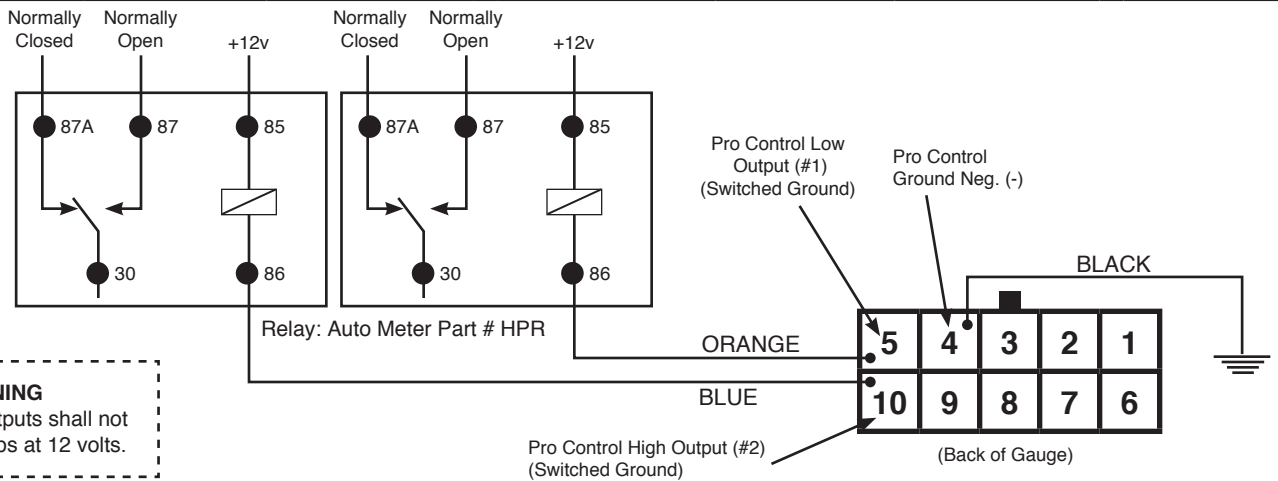

WARNING
Pro Control Outputs shall not exceed 2.0 amps at 12 volts.