

Roll Pod Installation - Tachometer

1. Remove the factory installed tachometer base from the tachometer. The threaded spacer, two bolts, and lockwashers will be re-used when installing the Roll Pod.
2. Remove all pieces from packaging.
3. Assemble the two Roll Bar Bracket Clamps in the desired mounting position.
4. Install four #8-32 x 3/4" Allen screws until the Bracket Clamps fit snug, do not fully tighten.
5. Install both the supplied threaded spacer and the threaded spacer from your tachometer into one of the new Tachometer Base halves.
6. Insert the threaded spacers into the other half of the Tachometer Base matching the molded configuration of the first half.
7. Configure the tachometer Shock Strap on the Tachometer Base with the strap tabs fitting into either molded angle on the Base (See Fig. 1) Install the tachometer base on the ball of the roll bar bracket.
8. Install the two new bolts, flatwashers, and lockwashers in the threaded spacer on the non-strap holding side of the Tachometer Base. Do not fully tighten bolts.
9. Remove tachometer from shock strap, loosely fasten one end of the Tachometer Shock Strap to the Tachometer Base using one bolt and lockwasher.
10. Install the tachometer into the Shock Strap positioning it for easy readability; install the remaining bolt and lockwasher into the tachometer base.
11. Position the complete assembly with the tachometer positioned so it is readable and does not block the view of the driver.
12. Once the tachometer position has been decided, tighten the screws on the Roll Bar Bracket Clamp to 15 in./lbs., tighten the bolts on the Tachometer Base to 50 in./lbs.

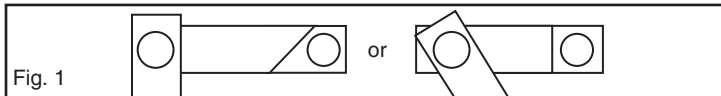
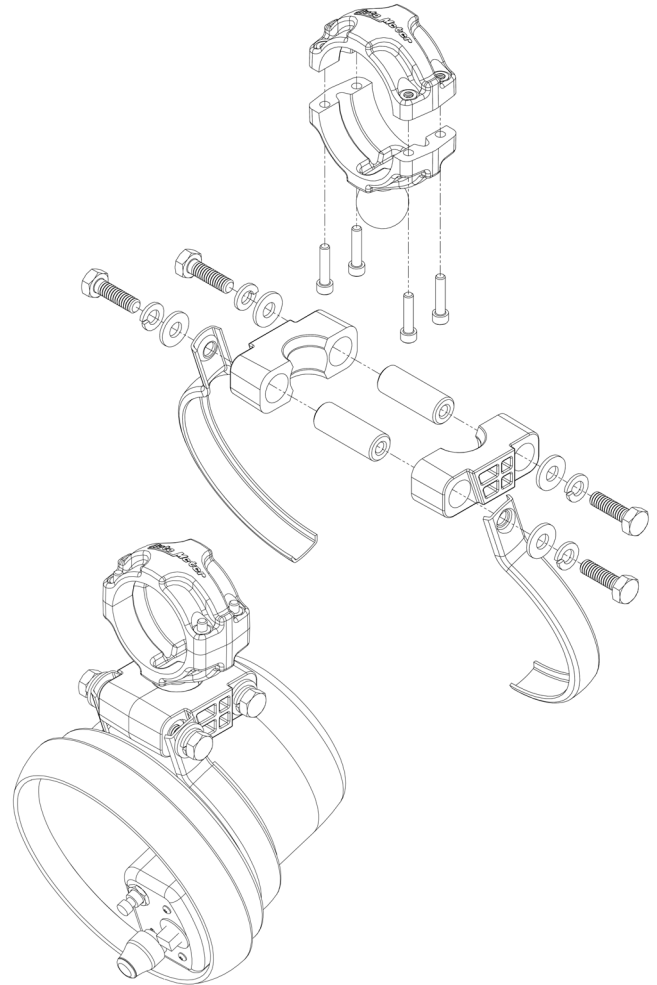

Roll Pod Installation - Gauge

1. Remove all pieces from packaging.
2. Mounting studs on gauge may have to be cut.
3. Install two #8-32 x 3/4" Allen screws into the gauge Clamps, tighten until snug.
4. Assemble the two Roll Bar Bracket Clamps in the desired mounting position.
5. Install four #8-32 x 3/4" Allen screws until the Bracket Clamps fit snug, do not fully tighten.
6. Slide rear cover into gauge clamp and route all permanent gauge wiring and tubing.
7. Install and position the gauge in the desired position. Position the gauge so it is readable and does not block the view of the driver.
8. Once the gauge position has been decided, tighten the screws on the Roll bar Bracket Clamp and Gauges Clamp to 15 in./lbs.

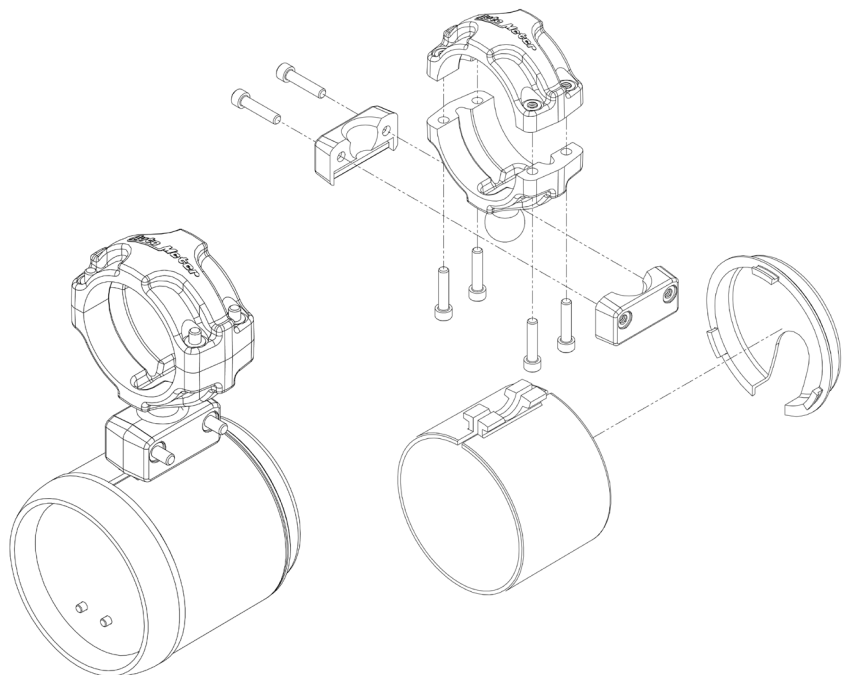

Pedestal Pod Installation - Tachometer

1. Remove the factory installed tachometer base from the tachometer. The threaded spacer, two-bolts, and lockwashers will be re-used when installing the Roll Pod.
2. Remove all pieces from packaging.
3. Position the Pedestal Mount on a flat surface in the desired mounting location. Using the four #8 x 5/8" self tapping screws, attach the pedestal to the surface.
4. Install both the supplied threaded spacer and the threaded spacer from your tachometer into one of the new Tachometer Base halves.
5. Insert the threaded spacers into the other half of the Tachometer Base matching the molded configuration of the first half.
6. Configure the tachometer Shock Strap on the Tachometer Base with the strap tabs fitting into either molded angle on the Base (See Fig. 1) Install the tachometer base on the ball of the Pedestal Mount.
7. Install the two new bolts, flatwashers, and lockwashers in the threaded spacer on the non-strap holding side of the Tachometer Base. Do not fully tighten bolts.
8. Remove tachometer from shock strap, loosely fasten one end of the Tachometer Shock Strap to the Tachometer Base using one - bolt and lockwasher.
9. Install the tachometer into the Shock Strap positioning it for easy readability; install the remaining bolt and lockwasher into the tachometer base.
10. Position the complete assembly with the tachometer positioned so it is readable and does not block the view of the driver.
11. Once the tachometer position has been decided, tighten the bolts on the Tachometer Base to 50 in./lbs.

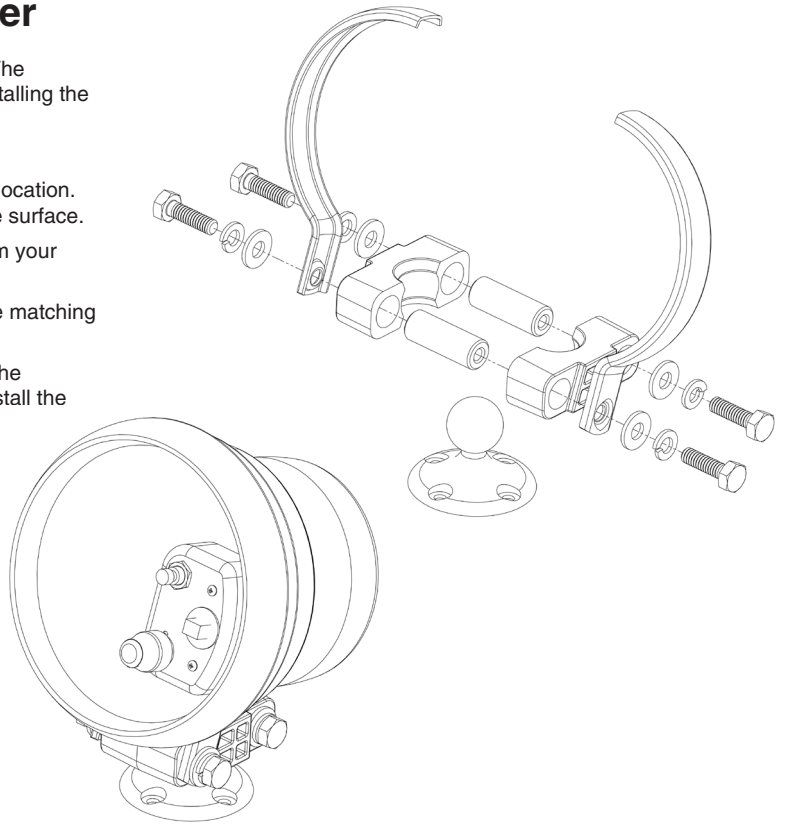

Pedestal Pod Installation - Gauge

1. Remove all pieces from packaging.
2. Mounting studs on gauge may have to be cut.
3. Install two #8-32 x 3/4" Allen screws into the gauge Clamps, tighten until snug.
4. Position the Pedestal Mount on a flat surface in the desired mounting location. Using the four #8 x 5/8" self tapping screws, attach the pedestal to the surface.
5. Slide rear cover into gauge clamp and route all permanent gauge wiring and tubing.
6. Install and position the gauge in the desired position. Position the gauge so it is readable and does not block the view of the driver.
7. Once the gauge position has been decided, tighten the screws on the Clamp to 15 in./lbs.

