



Developed in conjunction with Purkeys Fleet Electric



AC-68

Trailer Single Pole Circuit Voltage Drop Testing Guide

All wiring/components below are in addition to a base trailer when a lift gate has been added. These are all incorporated with the lift gate only.

CHARGING AND MOTOR CIRCUIT DIAGRAM

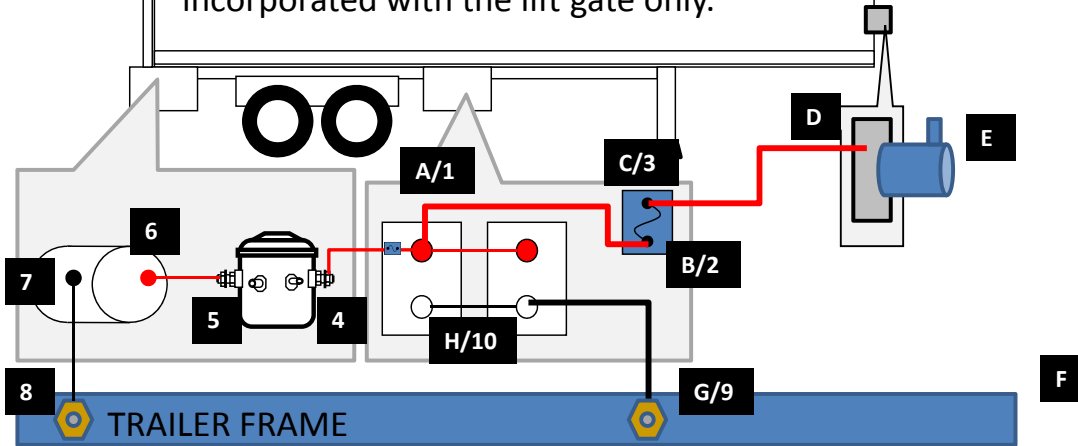

Output (Motor) Circuit

- | | |
|-------------------------------------|---|
| 1. Battery Positive | 6. Pump Motor Positive |
| 2. Circuit Breaker (Hot Side) | 7. Pump Motor Negative |
| 3. Circuit Breaker (Protected Side) | 8. Frame Rail Motor Ground Connection |
| 4. Magnetic Switch In | 9. Frame Rail Battery Ground Connection |
| 5. Magnetic Switch Out | 10. Battery Negative |

Charging Circuit

- | |
|---|
| A. Battery Positive |
| B. Circuit Breaker (Hot Side) |
| C. Circuit Breaker (Protected Side) |
| D. Single Pole Positive |
| E. Single Pole Testing Adapter Positive |
| F. Trailer Frame At Front Of Trailer |
| G. Frame Rail Battery Ground Connection |
| H. Battery Negative |

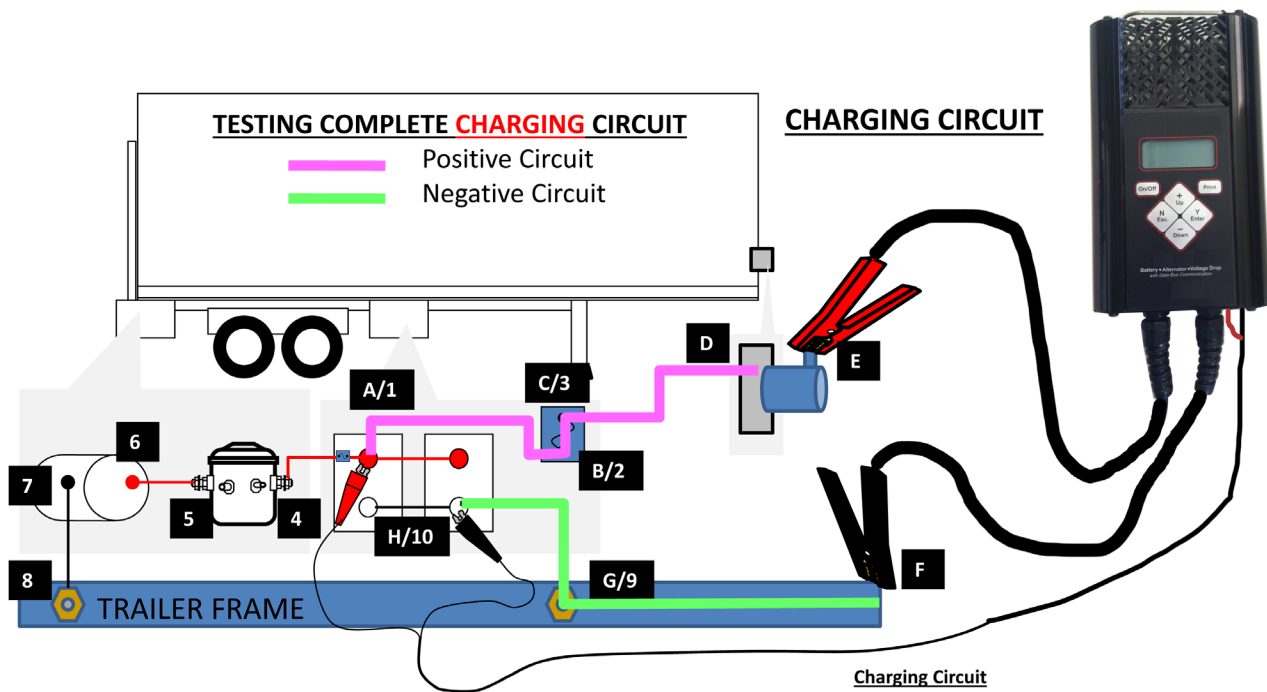

TESTING COMPLETE CHARGING CIRCUIT

- | |
|---|
| — Positive Circuit |
| — Negative Circuit |

CHARGING CIRCUIT

Output (Motor) Circuit

- | | |
|-------------------------------------|---|
| 1. Battery Positive | 6. Pump Motor Positive |
| 2. Circuit Breaker (Hot Side) | 7. Pump Motor Negative |
| 3. Circuit Breaker (Protected Side) | 8. Frame Rail Motor Ground Connection |
| 4. Magnetic Switch In | 9. Frame Rail Battery Ground Connection |
| 5. Magnetic Switch Out | 10. Battery Negative |

Charging Circuit

- | |
|---|
| A. Battery Positive |
| B. Circuit Breaker (Hot Side) |
| C. Circuit Breaker (Protected Side) |
| D. Single Pole Positive |
| E. Single Pole Testing Adapter Positive |
| F. Trailer Frame At Front Of Trailer |
| G. Frame Rail Battery Ground Connection |
| H. Battery Negative |

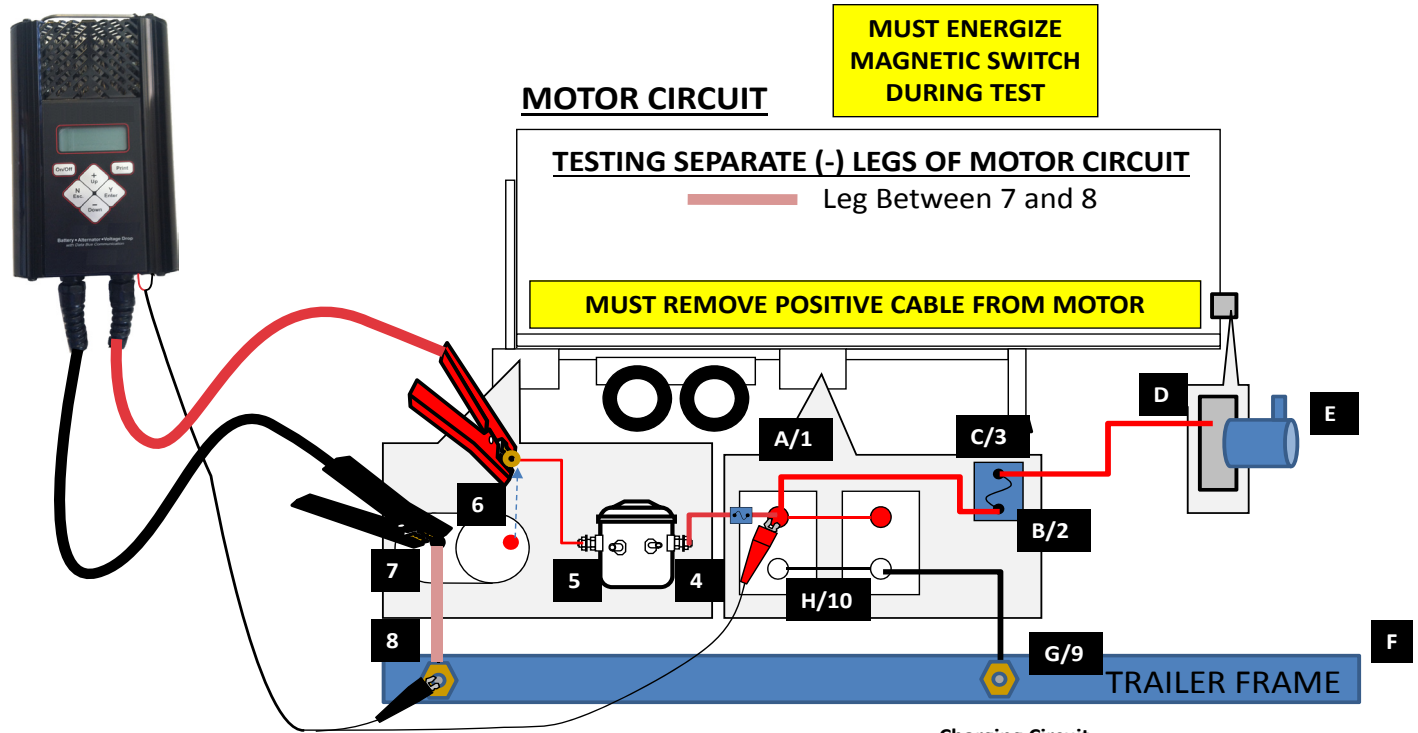

Output (Motor) Circuit

- | | |
|-------------------------------------|---|
| 1. Battery Positive | 6. Pump Motor Positive |
| 2. Circuit Breaker (Hot Side) | 7. Pump Motor Negative |
| 3. Circuit Breaker (Protected Side) | 8. Frame Rail Motor Ground Connection |
| 4. Magnetic Switch In | 9. Frame Rail Battery Ground Connection |
| 5. Magnetic Switch Out | 10. Battery Negative |

Charging Circuit

- | |
|---|
| A. Battery Positive |
| B. Circuit Breaker (Hot Side) |
| C. Circuit Breaker (Protected Side) |
| D. Single Pole Positive |
| E. Single Pole Testing Adapter Positive |
| F. Trailer Frame At Front Of Trailer |
| G. Frame Rail Battery Ground Connection |
| H. Battery Negative |

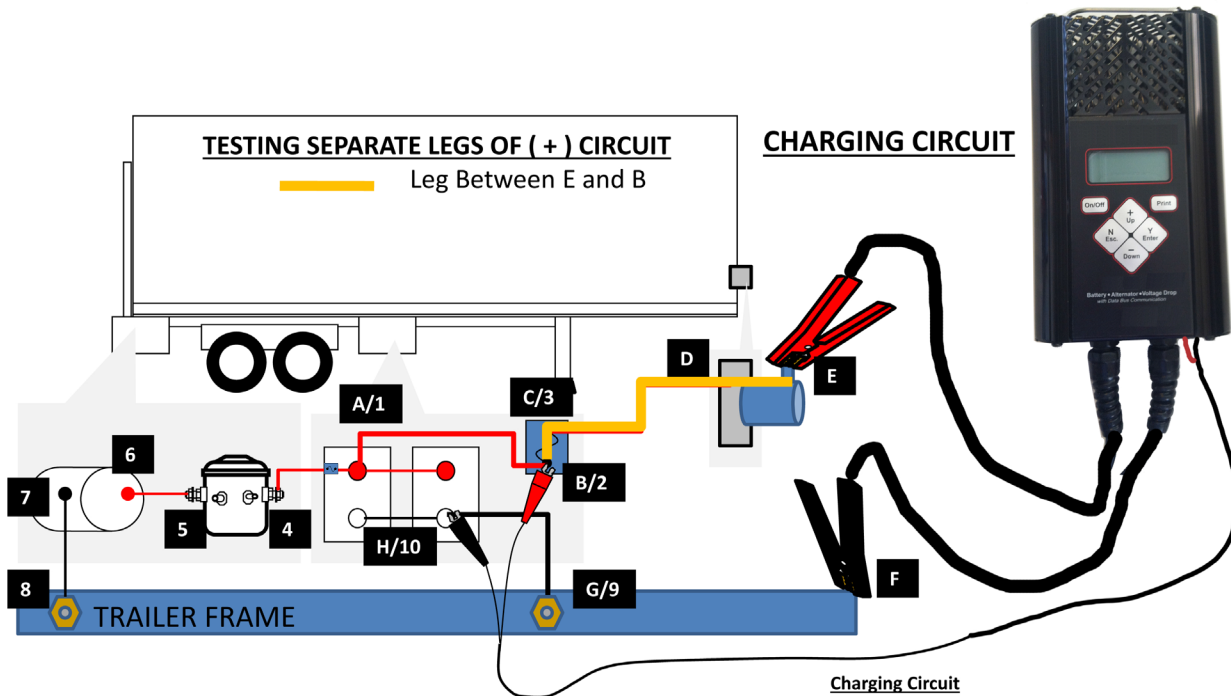

Output (Motor) Circuit

- | | |
|-------------------------------------|---|
| 1. Battery Positive | 6. Pump Motor Positive |
| 2. Circuit Breaker (Hot Side) | 7. Pump Motor Negative |
| 3. Circuit Breaker (Protected Side) | 8. Frame Rail Motor Ground Connection |
| 4. Magnetic Switch In | 9. Frame Rail Battery Ground Connection |
| 5. Magnetic Switch Out | 10. Battery Negative |

Charging Circuit

- | |
|---|
| A. Battery Positive |
| B. Circuit Breaker (Hot Side) |
| C. Circuit Breaker (Protected Side) |
| D. Single Pole Positive |
| E. Single Pole Testing Adapter Positive |
| F. Trailer Frame At Front Of Trailer |
| G. Frame Rail Battery Ground Connection |
| H. Battery Negative |

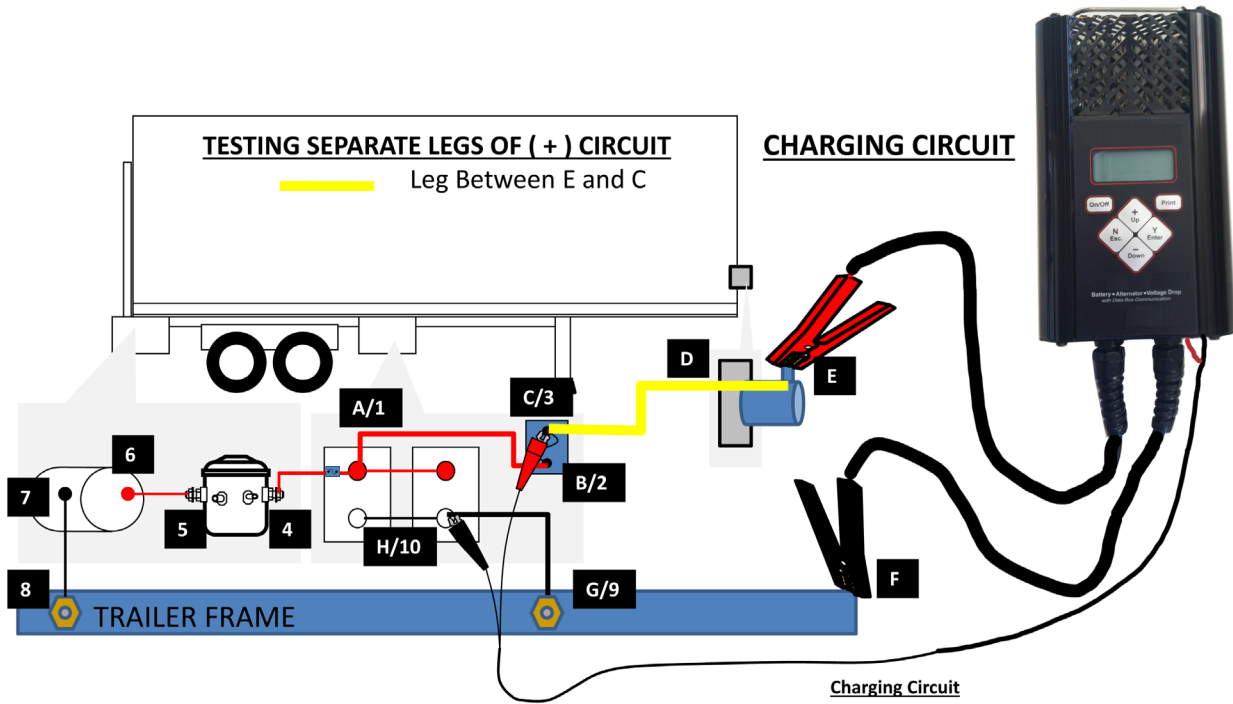

Output (Motor) Circuit

- | | |
|-------------------------------------|---|
| 1. Battery Positive | 6. Pump Motor Positive |
| 2. Circuit Breaker (Hot Side) | 7. Pump Motor Negative |
| 3. Circuit Breaker (Protected Side) | 8. Frame Rail Motor Ground Connection |
| 4. Magnetic Switch In | 9. Frame Rail Battery Ground Connection |
| 5. Magnetic Switch Out | 10. Battery Negative |

Charging Circuit

- | |
|---|
| A. Battery Positive |
| B. Circuit Breaker (Hot Side) |
| C. Circuit Breaker (Protected Side) |
| D. Single Pole Positive |
| E. Single Pole Testing Adapter Positive |
| F. Trailer Frame At Front Of Trailer |
| G. Frame Rail Battery Ground Connection |
| H. Battery Negative |

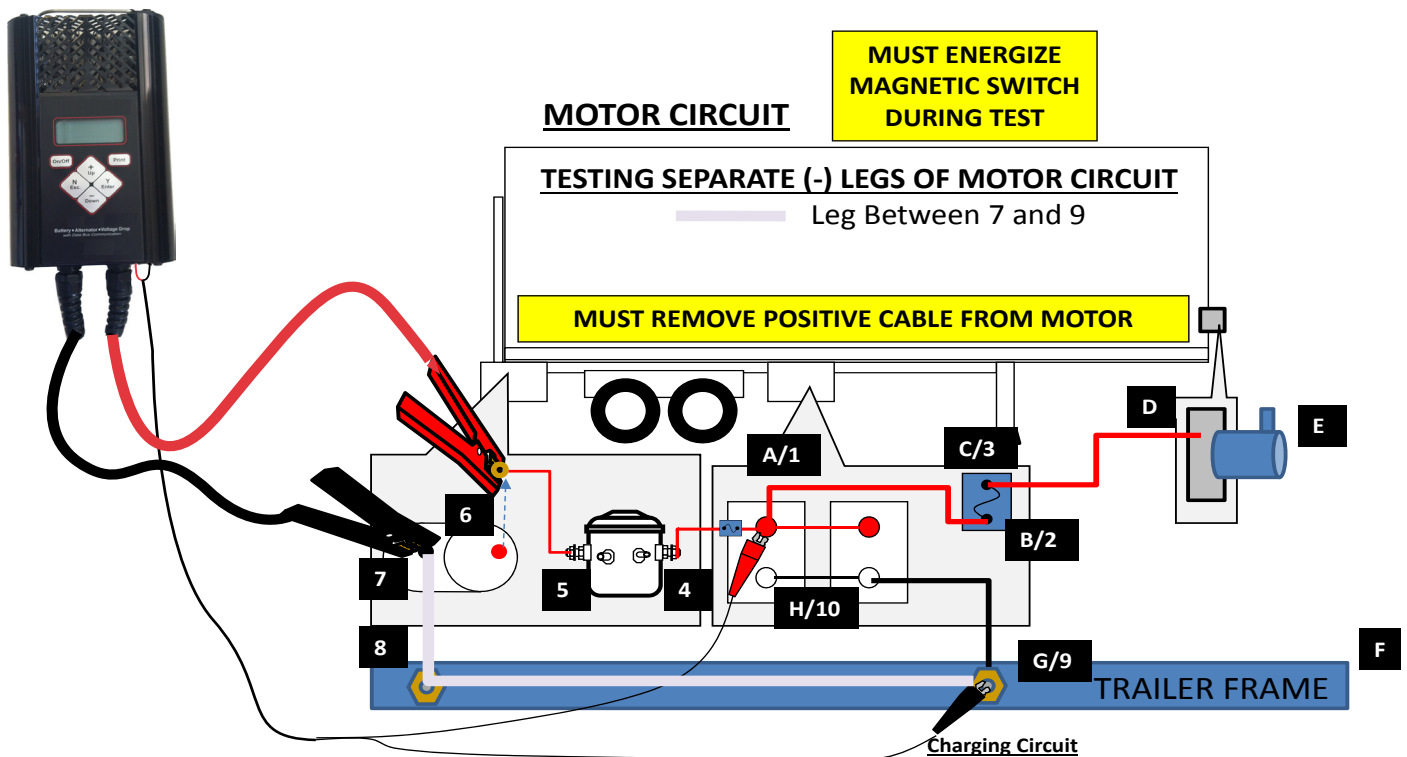

Output (Motor) Circuit

- | | |
|-------------------------------------|---|
| 1. Battery Positive | 6. Pump Motor Positive |
| 2. Circuit Breaker (Hot Side) | 7. Pump Motor Negative |
| 3. Circuit Breaker (Protected Side) | 8. Frame Rail Motor Ground Connection |
| 4. Magnetic Switch In | 9. Frame Rail Battery Ground Connection |
| 5. Magnetic Switch Out | 10. Battery Negative |

Charging Circuit

- | |
|---|
| A. Battery Positive |
| B. Circuit Breaker (Hot Side) |
| C. Circuit Breaker (Protected Side) |
| D. Single Pole Positive |
| E. Single Pole Testing Adapter Positive |
| F. Trailer Frame At Front Of Trailer |
| G. Frame Rail Battery Ground Connection |
| H. Battery Negative |

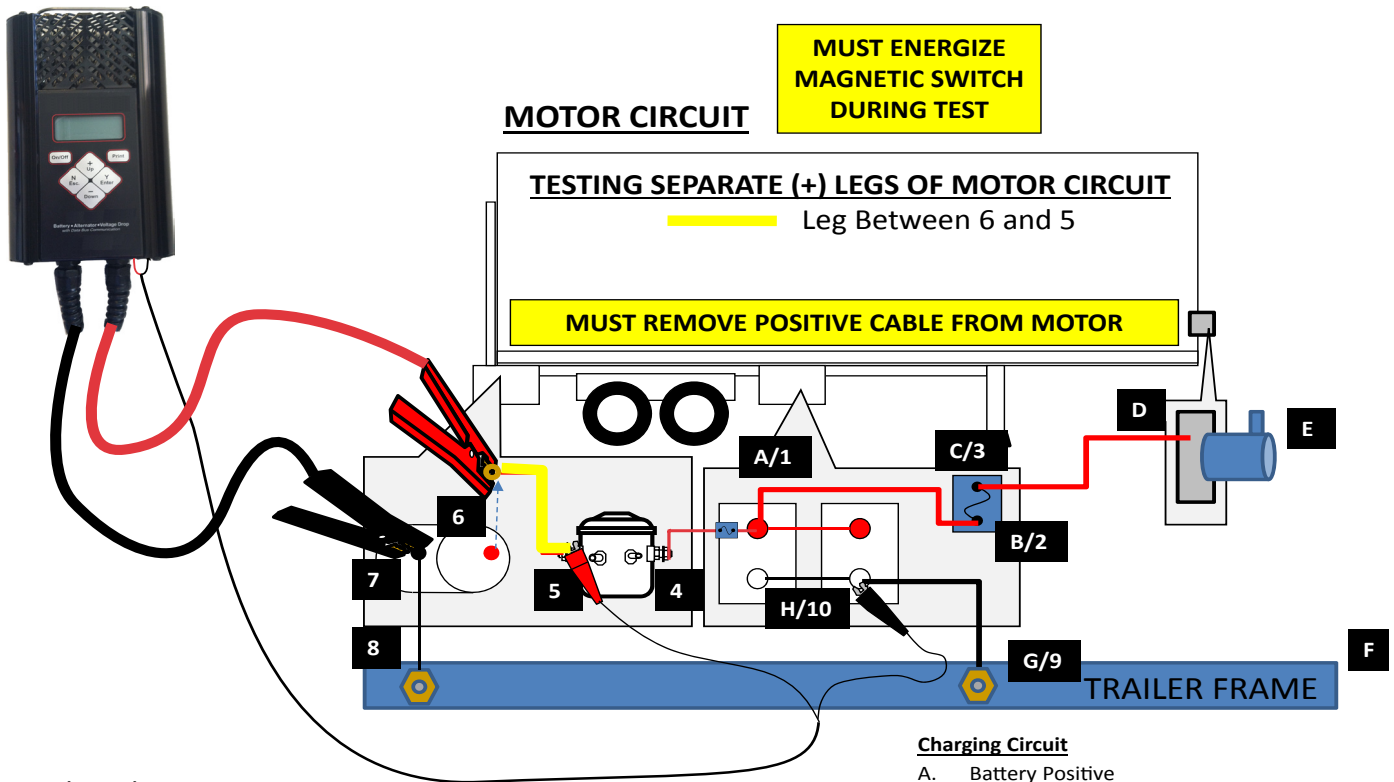

Output (Motor) Circuit

- | | |
|-------------------------------------|---|
| 1. Battery Positive | 6. Pump Motor Positive |
| 2. Circuit Breaker (Hot Side) | 7. Pump Motor Negative |
| 3. Circuit Breaker (Protected Side) | 8. Frame Rail Motor Ground Connection |
| 4. Magnetic Switch In | 9. Frame Rail Battery Ground Connection |
| 5. Magnetic Switch Out | 10. Battery Negative |

Charging Circuit

- | |
|---|
| A. Battery Positive |
| B. Circuit Breaker (Hot Side) |
| C. Circuit Breaker (Protected Side) |
| D. Single Pole Positive |
| E. Single Pole Testing Adapter Positive |
| F. Trailer Frame At Front Of Trailer |
| G. Frame Rail Battery Ground Connection |
| H. Battery Negative |

CHARGING CIRCUIT

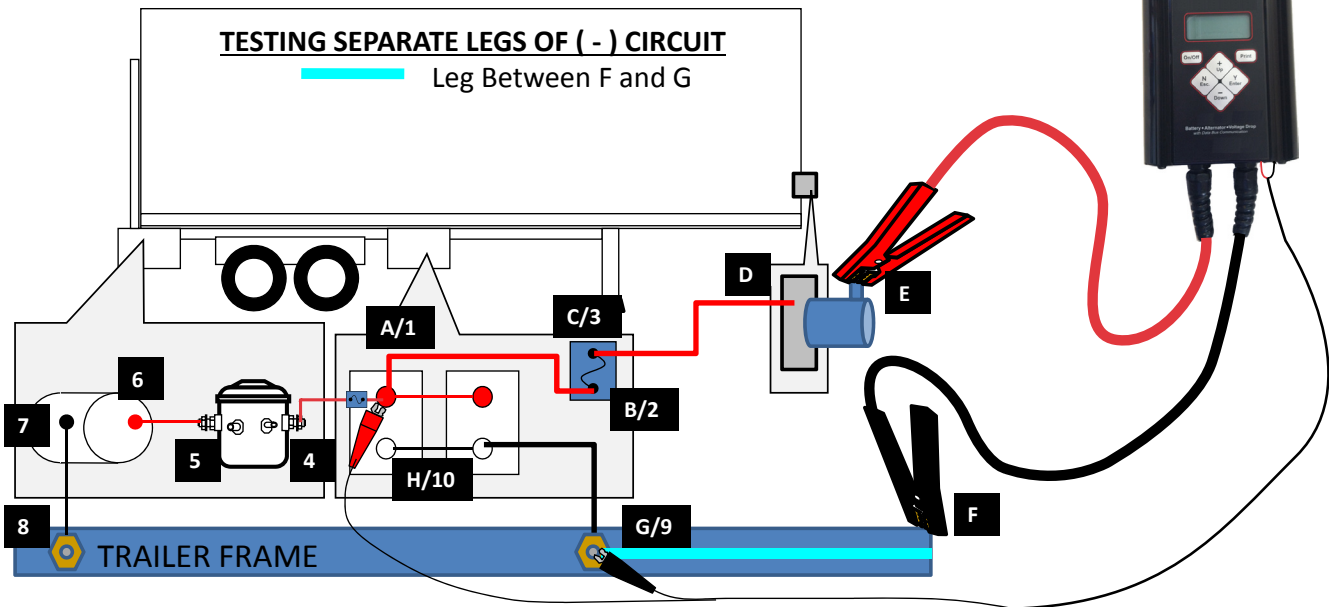

Output (Motor) Circuit

- | | |
|-------------------------------------|---|
| 1. Battery Positive | 6. Pump Motor Positive |
| 2. Circuit Breaker (Hot Side) | 7. Pump Motor Negative |
| 3. Circuit Breaker (Protected Side) | 8. Frame Rail Motor Ground Connection |
| 4. Magnetic Switch In | 9. Frame Rail Battery Ground Connection |
| 5. Magnetic Switch Out | 10. Battery Negative |

- | |
|---|
| A. Battery Positive |
| B. Circuit Breaker (Hot Side) |
| C. Circuit Breaker (Protected Side) |
| D. Single Pole Positive |
| E. Single Pole Testing Adapter Positive |
| F. Trailer Frame At Front Of Trailer |
| G. Frame Rail Battery Ground Connection |
| H. Battery Negative |

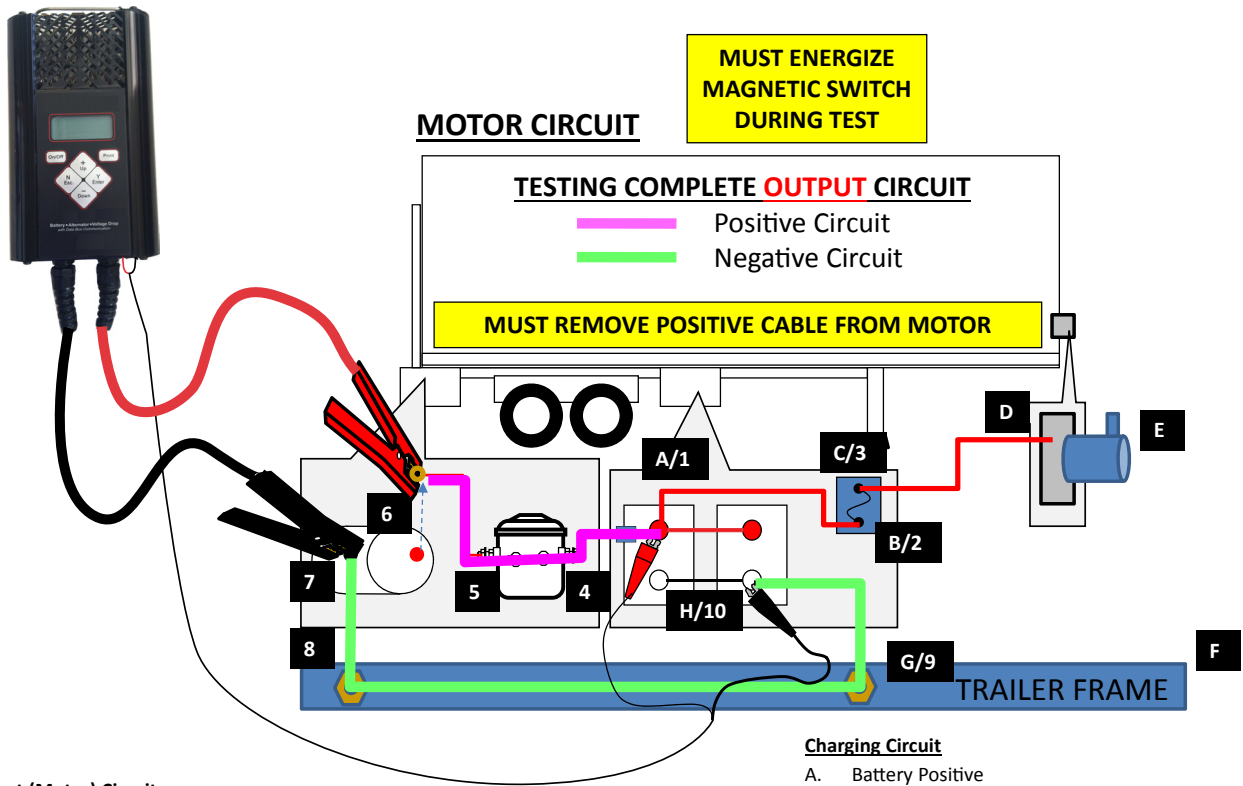

Output (Motor) Circuit

- | | |
|-------------------------------------|---|
| 1. Battery Positive | 6. Pump Motor Positive |
| 2. Circuit Breaker (Hot Side) | 7. Pump Motor Negative |
| 3. Circuit Breaker (Protected Side) | 8. Frame Rail Motor Ground Connection |
| 4. Magnetic Switch In | 9. Frame Rail Battery Ground Connection |
| 5. Magnetic Switch Out | 10. Battery Negative |

Charging Circuit

- | |
|---|
| A. Battery Positive |
| B. Circuit Breaker (Hot Side) |
| C. Circuit Breaker (Protected Side) |
| D. Single Pole Positive |
| E. Single Pole Testing Adapter Positive |
| F. Trailer Frame At Front Of Trailer |
| G. Frame Rail Battery Ground Connection |
| H. Battery Negative |

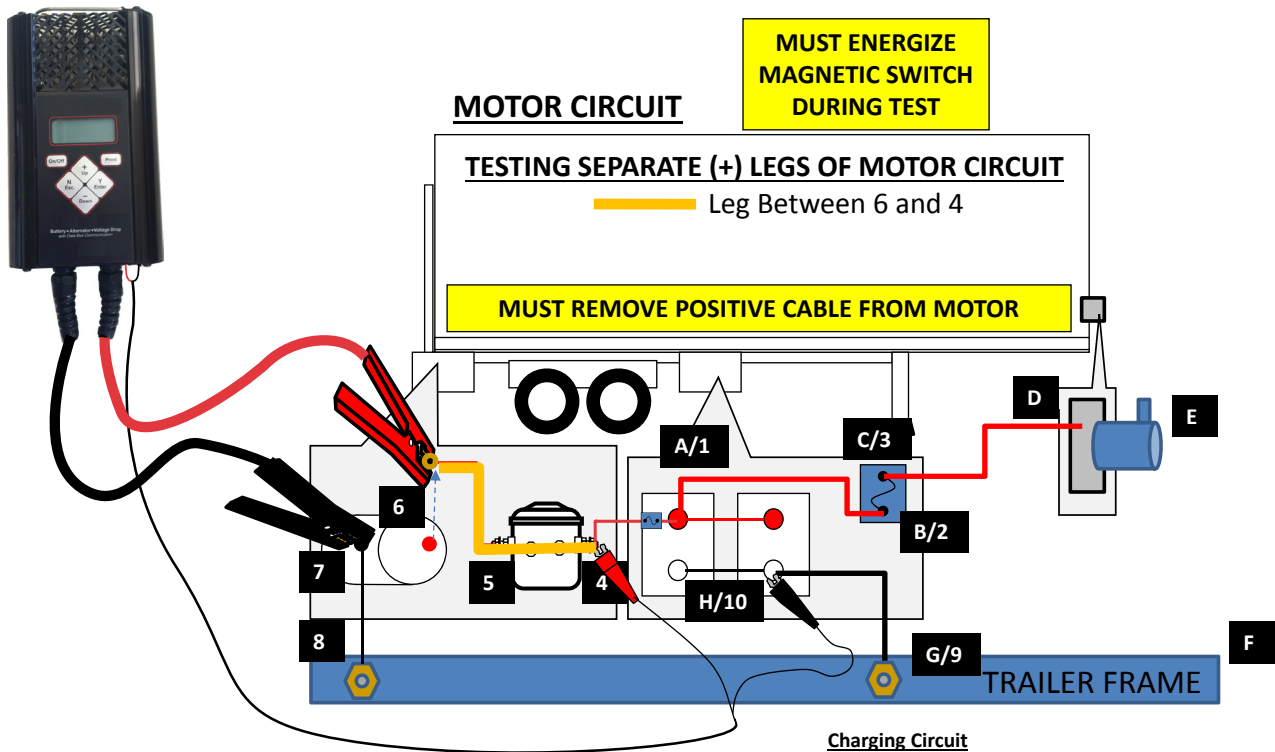

Output (Motor) Circuit

- | | |
|-------------------------------------|---|
| 1. Battery Positive | 6. Pump Motor Positive |
| 2. Circuit Breaker (Hot Side) | 7. Pump Motor Negative |
| 3. Circuit Breaker (Protected Side) | 8. Frame Rail Motor Ground Connection |
| 4. Magnetic Switch In | 9. Frame Rail Battery Ground Connection |
| 5. Magnetic Switch Out | 10. Battery Negative |

Charging Circuit

- | |
|---|
| A. Battery Positive |
| B. Circuit Breaker (Hot Side) |
| C. Circuit Breaker (Protected Side) |
| D. Single Pole Positive |
| E. Single Pole Testing Adapter Positive |
| F. Trailer Frame At Front Of Trailer |
| G. Frame Rail Battery Ground Connection |
| H. Battery Negative |