

Wiring Installation Instructions for : Nitrous Pressure 2 1/16" Spek Pro Professional Racing Gauge

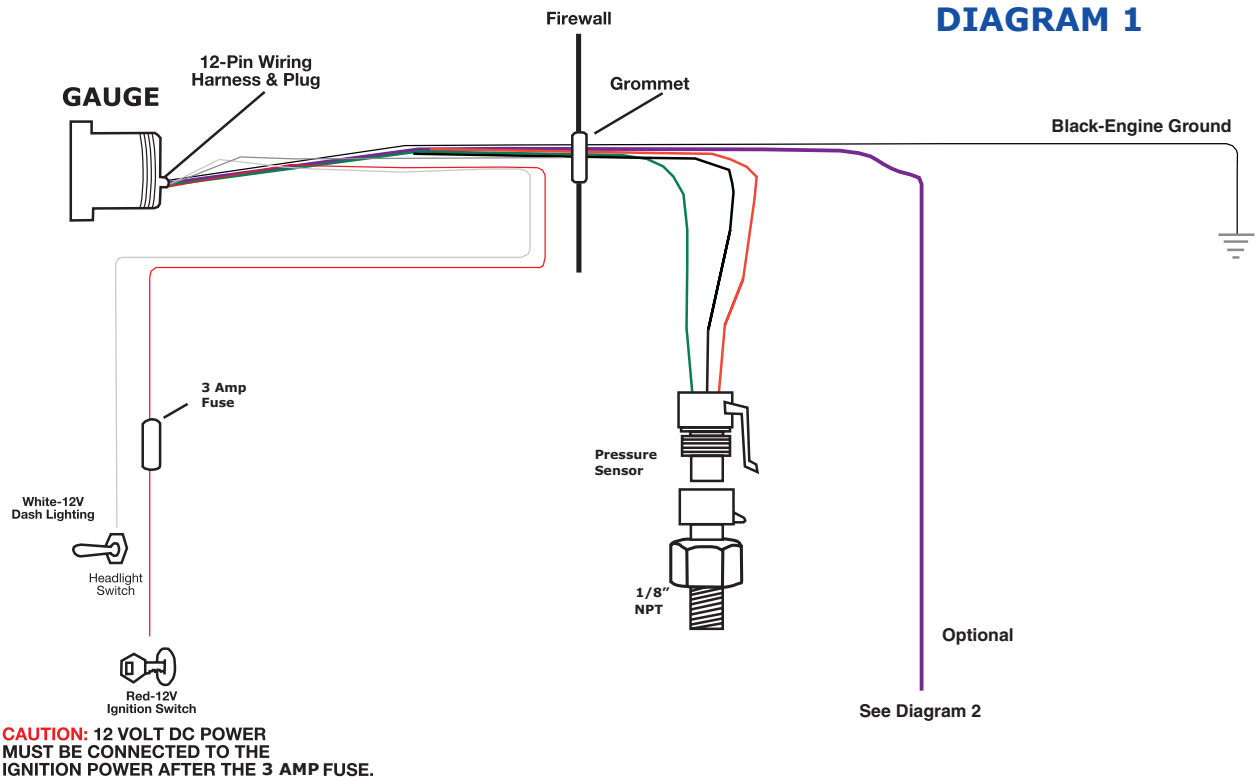

Optional: Wiring a Relay for Gauge Controlled Output

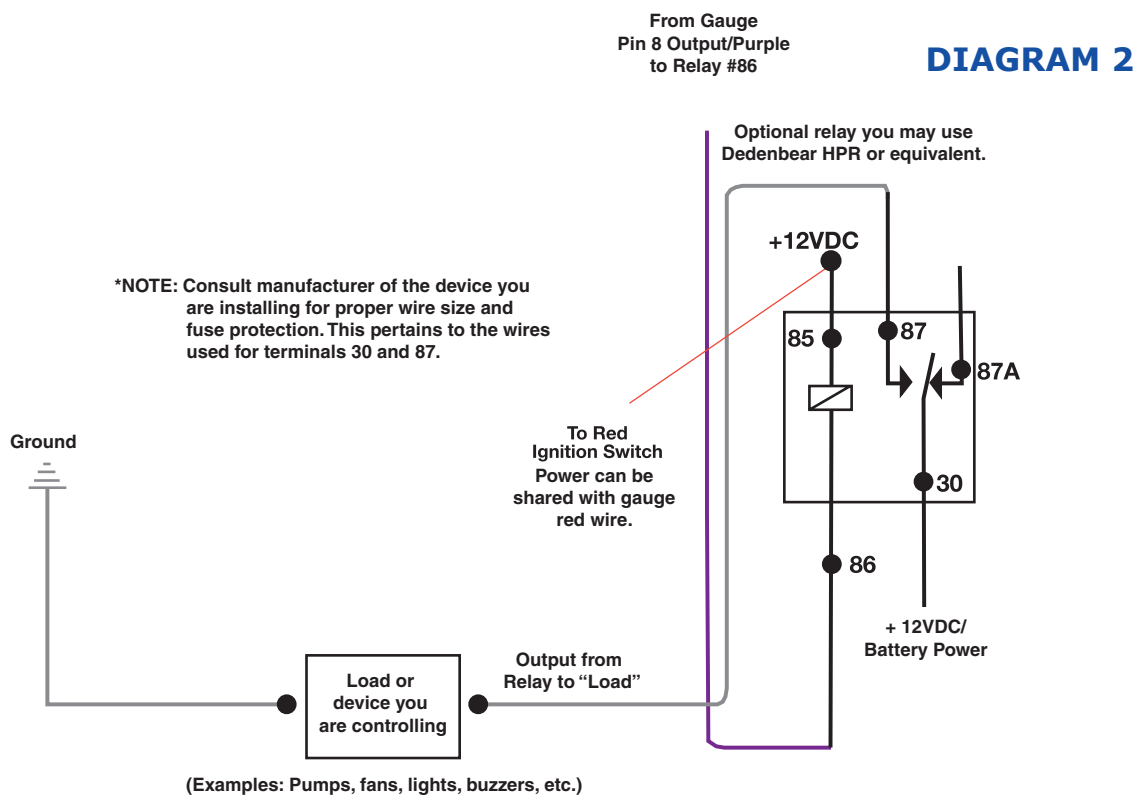

Installing the Pressure Sending Unit:

This can be installed either at the nitrous bottle or at the nitrous solenoid. If mounting at the bottle, most nitrous manufacturers already offer a gauge adapter to install between the bottle valve and the line. Examples of this are NOS 16103 or Edelbrock 76512. You may check with your nitrous kit manufacturer for other model numbers. When mounting to the bottle, it may be necessary to lengthen the wire harness. When doing this we recommend soldering and heat shrinking your connections.

If you chose to mount the sender at the nitrous bottle, we recommend contacting your nitrous manufacturer for the proper fitting(s). The sender for this gauge uses 1/8" NPT thread size. If your solenoid size is 1/8" NPT, you may use a fitting such as the NOS 16777 or similar.

We recommend using a small amount of liquid or paste based sealant on any pipe threads (npt fittings), but no sealant on any "AN" fittings.

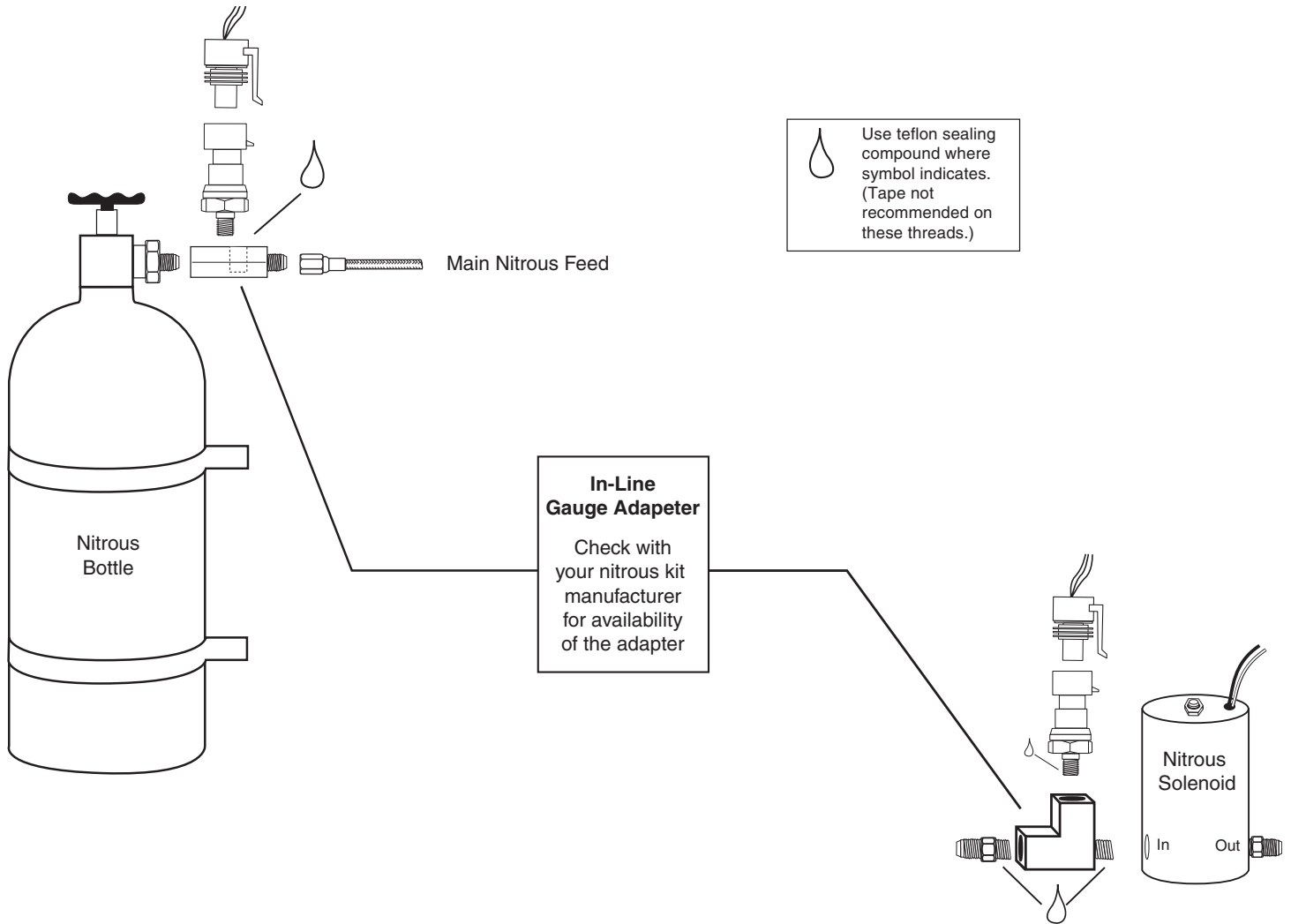

Wiring:

Red: Switched, key on power. Protect with 3 amp automotive fuse.

Black: Engine ground.

White: Dash lights dimming circuit (power controlled, not ground controlled)

Purple: Used for triggering (grounding) relay coil when low set point, or high set point of the gauge is triggered.

Programming and Using Your Gauge



Programming:

The programming is achieved in steps, using the middle button on the face of the gauge. Think of the middle button as a "MODE" button. The Left & Right buttons are basically "Down" & "Up" buttons. Please note that each push & release of the buttons require about a 1 second push to activate. A quick tap may not register to the gauge that you have pushed the button. This built in delay is intentional to prevent accidental setting changes.

Illumination Brightness (when no power from dash lighting is used)

This is one of the only steps that you do NOT use the middle button for. This also must have pressure applied on pressure gauges, so that the gauge is NOT warning you of low pressure to be able to see the change in brightness. Simply push and hold the left button to lower the brightness or push and hold the right button to increase the brightness. The gauge pointer will raise and lower with the brightness to indicate current brightness relative to min. and max., however the gauge will return to normal reading almost immediately after the last button push.

Programming: Cont.

Peak

With power on, the first press and release of the middle button will display PEAK. The pointer will move to the peak reading and PEAK will continue to flash. If no button is pushed for about 30 seconds, the gauge will default back to the current reading and peak automatically clears. To clear the peak without waiting for the time-out, push either the left or the right button while in Peak-Mode. If you do not want peak cleared, push and release the middle button 5 times to cycle through all of the remaining menus and back to normal operation.

High Warn Set Point

While in Peak mode, push and release the middle button. The pointer will move to the current high set point and HI will continue to flash. While in HI set mode, push and hold left button to move set point lower or push and hold right button to move the set point higher. If no button is pushed for about 30 seconds the gauge will default back to the current reading. It will also store the last HI set point adjustment. When readings are above High Set Point, the word HI will illuminate. The gauge will illuminate red, and start flashing.

Low Warn Set Point

While in High Warn Set Point, push & release the middle button. The pointer will move to the current low set point, and LOW will continue to flash. While in Low Set Mode, push and hold left button to move set point lower or push and hold right button to move the set point higher. If no button is pushed for about 30 seconds the gauge will default back to the current reading. It will also store the last LOW set point adjustment. When readings are below LOW set point, the word LOW will illuminate. The gauge will illuminate red and start flashing.

Gauge Illumination Color Set Point

While in Low Warn Set Point, push and release the middle button. The pointer will move to a predetermined reading on the scale (associated with the current color selected) and the face illumination will begin to flash about once every second. The words PEAK, LOW, and HI will also flash together about once every second. Push and release the left button to move the pointer down which also changes the illumination color. Push and release the right button to move the pointer back up, which changes the illumination color. Each left and right button push requires about a 1-second push. If no button is pushed for about 30 seconds the gauge will default back to the current reading and the last color selected will be stored. If no color (illumination color off) is selected, the lighting will remain off except for the lit pointer. The face will still warn and light up in red if a low warning is detected.

Changing Lit Pointer Brightness

While in the Gauge Illumination Color Set Point Mode, push and release the middle button. The color will continue to flash like it does in Gauge Illumination Color Set Mode, however the PEAK, HI, and LOW indicators will no longer be flashing. Press and hold the left button and the middle button at the same time. The pointer will step all the way up to maximum gauge reading while you are holding the pair of buttons in. Release the buttons when maximum gauge reading is achieved. The illumination will turn off (except for the pointer). You may use the left and right buttons to adjust the pointer brightness. You may either press and release the middle button to store it and to return to normal function, or just let it time out after about 30 seconds.

Demo Mode

While in Gauge Illumination Color Set Point Mode, push and hold the middle button and the right button at the same time. Continue to hold until the pointer reaches maximum reading. Release the two buttons. The gauge will now continuously operate in Demo mode (changing colors, and sweeping back and forth) until any button is pushed and released. It will then return to normal operation.

Factory Reset

While in Peak Mode, press and hold the middle button and the right button at the same time until the pointer moves to maximum reading. Release both buttons. The gauge will now reset to all factory default settings.

Gauge Output Control Wire (purple wire).

The purple wire can be used to ground/activate a relay if you want to control another device whenever the gauge goes into LOW Warning, or when the gauge goes into HIGH warning for temperature gauges. The purple wire will ground the "coil-side" of a common relay, with a maximum load capability of 1.5A (on the purple wire). Generally you would run a key-on power source to terminal 85. Run the purple wire to terminal 86. Connect your power source (most cases battery positive) for the device that you want to control to terminal 30. Terminal 87 will now be that same power source leading to your controlled device anytime the relay is activated (when pressure goes to your LOW, or HIGH Warn Set Point. See diagram 2.).



Oil/Water Pressure Programming Quick Reference Guide

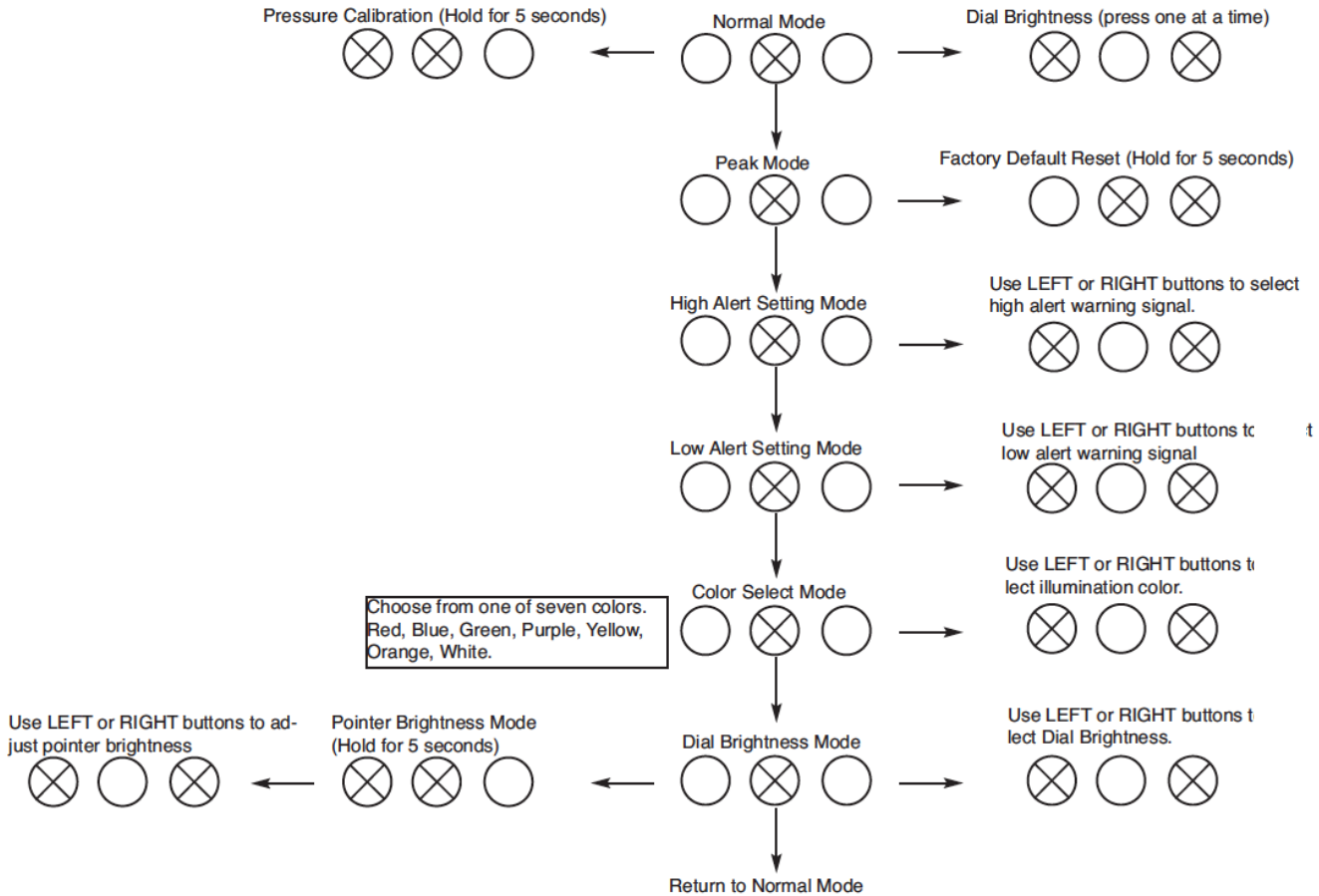

Choose from one of seven colors. Red, Blue, Green, Purple, Yellow, Orange, White.

