

## Programming Instructions for : Temperature 2 1/16" Spek Pro Racing Gauge - NASCAR ECU Compatible

### SPEK PRO™ MONITOR AND CONTROL

**Refer to the "Flow Chart Programming Instructions" while reviewing this guide.**

Gauge is field programmable by the operator while installed in the vehicle. This programming is accessed by pressing the control buttons located on the face or the meter dial, **ONE AT A TIME**. The "Down" and "Up" buttons move the pointer to a desired setting or controls the faceplate illumination.



MAIN MENU		SUBMENU	
PRESS "MODE" BUTTON TO PROGRAM LEVEL. THEN PRESS BOTH CENTER AND LEFT OR CENTER AND RIGHT BUTTONS FOR FIVE SECONDS TO ENTER SUBMENU			
NORMAL/DIAL BRIGHTNESS		OPTION: MONITOR ECU FUEL INJECTION OR PRESSURE SENSOR	
PEAK PLAYBACK		OPTION: RESTORE FACTORY DEFAULT	
HIGH RED-LINE SETTING			
LOW THRESHOLD SETTING			
COLOR SCHEME		OPTION A: DEMO MODE	
DIAL BRIGHTNESS		OPTION : ADJUST POINTER BRIGHTNESS	

# Programming Instructions for : Temperature 2 1/16" Spek Pro Racing Gauge - NASCAR ECU Compatible

## PROGRAMMING STARTS IN MAIN MENU

PRESS PROGRAM BUTTON ONE (1) AT A TIME IN THE **MAIN MENU** MODE.

### 1 **NORMAL/DIAL BRIGHTNESS:**

On power up, the meter usually starts operation in **NORMAL/DIAL BRIGHTNESS**. Gauge reads the sensor value as temperature, pressure, etc. The "Down" and "Up" buttons will control the brightness of the dial lighting. Press the center "Mode" button to save the setting and advance you to **PEAK PLAYBACK**

### 2 **PEAK PLAYBACK:**

Reads the highest value displayed on the gauge since the last time the **PEAK** value was displayed. **PEAK** value will be held in memory until erased by pressing the RIGHT or LEFT buttons while in the **PEAK** level. Press the center "Mode" button to advance to **HIGH RED-LINE SETTING**

### 3 **HIGH RED-LINE SETTING:**

Water, Oil, Transmission, and Differential gauges have a programmable thermostat control to activate the existing cooling fan. Sets the point at which "HIGH" warning threshold is reached for that specific gauge. The "Down" and "Up" buttons will move the dial pointer to select **HIGH RED-LINE SETTING**. During normal operation the gauge constantly monitors the sensor value and compares it to the "HIGH" threshold. If the threshold is exceeded, the red "**HI**" indicator and fan are turned on. Press the center "Mode" button to save the setting and advance to **LOW THRESHOLD SETTING**

### 4 **LOW THRESHOLD SETTING:**

Set the Minimum Threshold: Sets the point at which "**LOW**" warning threshold is reached for that specific gauge. The "Down" and "Up" buttons will move the dial pointer to select the **LOW THRESHOLD SETTING**. During normal operation the gauge constantly monitors the sensor value and compares it to the "**LOW**" threshold. If the sensor value drops below the threshold, the yellow "**LOW**" indicator is turned on fan is turned off. Press the center "Mode" button save the setting and advance to

### 5 **COLOR SCHEME**

### 5 **COLOR SCHEME:**

Set Faceplate Color Scheme: Operator can select the color of the gauge dial illumination. Each time you press the "Down" control button you scroll through dial color selection until the dial light goes off. Then press the "Up" button to reverse the scroll. Select your dial color illumination by pressing the center "Mode" button to save the setting and advance to **NORMAL/DIAL BRIGHTNESS**

### 6 **DIAL BRIGHTNESS:**

Adjust the dial brightness for day or evening driving conditions The RIGHT and LEFT command buttons will dim or brighten the faceplate illumination. Press the center "Mode" button to save the setting and advance you to **NORMAL OPERATION**

# Programming Instructions for : Temperature

## 2 1/16" Spek Pro Racing Gauge - NASCAR ECU Compatible

### SUBMENU

**SUBMENU** IS ACCESSED THROUGH THE **MAIN MENU**. FIRST GO TO THE APPROPRIATE LEVEL OF THE **MAIN MENU** AND THEN FOLLOW THE INSTRUCTIONS IN THE PROGRAMMING FLOW DIAGRAM TO ENTER THE **SUBMENU**. PRESS THE "MODE" AND "UP" OR "MODE" AND "DOWN" BUTTONS SIMULTANEOUSLY FOR 5 SECONDS TO ENTER THE **SUBMENU** AND ONE BUTTON AT A TIME WHILE IN THAT **SUBMENU**.

#### **OPTION: MONITOR ECU FUEL INJECTION OR PRESSURE SENSOR:**

THE ECU IS THE FACTORY DEFAULT SETTING. TO CHANGE PROGRAM FIRST PUT +12 VOLTS ON THE WHITE / DIMMER CIRCUIT. WHILE IN THE NORMAL / DIAL BRIGHTNESS MODE, PRESS AND HOLD BOTH THE CENTER AND RIGHT BUTTONS FOR 5 SECONDS. THE FACEPLATE WILL LIGHT BLUE. THE POINTER WILL STEP FIVE TIMES AND RETURN TO ZERO. TO SELECT THE PROGRAM, USE THE RIGHT (UP) OR LEFT (DOWN) BUTTON TO MOVE THE POINTER TO DESIRED OPTION.

- \* MOVING POINTER TO ZERO (0) SETTING SELECTS MONITORING ECU FUEL INJECTION
- \* MOVING THE POINTER TO HIGHEST TEMPERATURE SETTING (300F) SELECTS MONITORING A TEMPERATURE SENSOR.
- \* PRESS THE CENTER (MODE) BUTTON TO SAVE THE PROGRAM.

**OPTION:RESTORE FACTORY DEFAULT:** While in PEAK PLAYBACK, Main Menu, Press and hold both the CENTER and RIGHT buttons for 5 seconds. The dial pointer will step 5 times and return to zero (0). All user programmed settings will be erased and the gauge will return to **NORMAL OPERATION**.

**OPTION A:DEMO MODE:** Displays the features of the meter. The pointer goes up and down the scale, the dial colors change and the **HI**, **LOW** and **PEAK** warning indicators light. The **DEMO MODE** does not time out. If the gauge is turned off in the **DEMO MODE**, it will start up in the **DEMO MODE**. Press the "Mode" button to return the gauge to NORMAL operation.

**OPTION :POINTER BRIGHTNESS MODE:** The "Down" and "UP" buttons adjust the dial pointer brightness to blend in with the original manufacturer's gauges and the owner's requirements. Press the "Mode" button to return the gauge to **NORMAL/DIAL BRIGHTNESS**.

# Programming Instructions for : Temperature 2 1/16" Spek Pro Racing Gauge - NASCAR ECU Compatible

## GAUGE CRITICAL CONDITION ALERT/OUTPUT GUIDE

GAUGE TYPE	ALERT FLASHES "RED"
TEMPERATURE	HIGH
PRESSURE	LOW
TACHOMETER	HIGH
PYROMETER	HIGH
NITROUS OXIDE PRESSURE	LOW
BOOST PRESSURE	HIGH
AIR/FUEL	LOW
VOLTMETER	LOW

**PRO-  
GRAM-**

### PROGRAMMING INFORMATION:

- TO RESET THE PROGRAM TO **NORMAL OPERATION** FROM ANY MODE PRESS THE "UP" AND "DOWN" BUTTONS SIMULTANEOUSLY. THIS SOFT RESET CANCELS THE INFORMATION YOU PROGRAMMED IN THAT MODE ONLY AND RETURN YOU TO **NORMAL OPERATION**.
- THE FACEPLATE WILL "FLASH" WHEN BUTTONS ARE DEPRESSED TO ACKNOWLEDGE COMMANDS.
- PROGRAMMING ERRORS WILL BE SIGNALLED BY FLASHING THE FACEPLATE LIGHTING "**PURPLE**", "**BLUE**", "**GREEN**" THEN "**ORANGE**".
- IF PROGRAMMING IS INACTIVE FOR 120 SECONDS THE MODE WILL TIME OUT AND THE GAUGE WILL RETURN TO NORMAL OPERATION, EXCEPT FOR IN THE DEMONSTRATION MODE. THE DEMO MODE WILL NOT TIME OUT UNTIL THE CENTER "MODE" BUTTON IS PRESSED. IF THE GAUGE IS TURNED OFF IN THE DEMO MODE, IT WILL START-UP IN THE DEMO MODE.
- TO RESTORE FACTORY DEFAULTS, PRESS THE "MODE" BUTTON ONCE TO ENTER THE **PEAK PLAYBACK**. THEN PRESS AND HOLD THE "MODE" AND "UP" BUTTONS FOR FIVE SECONDS. YOUR PROGRAMMING WILL BE ERASED BUT FACTORY PROGRAM WILL NOT BE AFFECTED.

### Factory Default Settings

Water Temperature .....250°F  
Oil Temperature.....270°F

# Flow Chart Programming Instructions for : Temperature - Software - MRECU0472

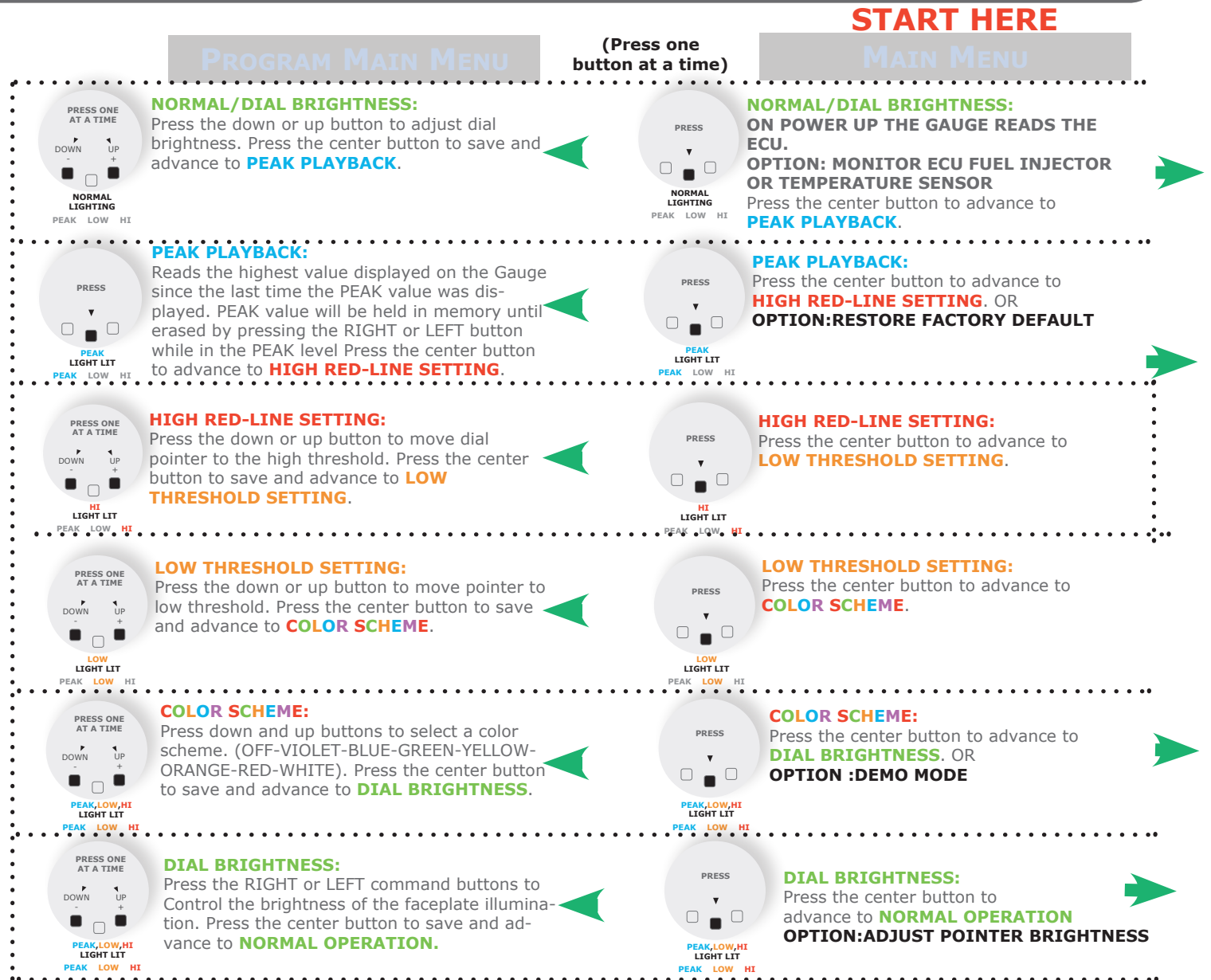

# Flow Chart Programming Instructions for : Temperature 2 1/16" Spek Pro Professional Racing Gauge



## SUBMENU

(ENTER FROM MAIN MENU)

(Press two(2) buttons simultaneously for 5 seconds)

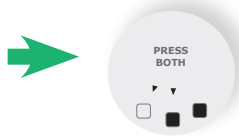

### OPTION: MONITOR ECU FUEL INJECTION OR SENSOR

THE ECU IS THE FACTORY DEFAULT SETTING. TO CHANGE PROGRAM FIRST PUT +12 VOLTS ON THE WHITE / DIMMER CIRCUIT. WHILE IN THE NORMAL / DIAL BRIGHTNESS MODE. THEN PRESS AND HOLD BOTH THE CENTER AND RIGHT BUTTONS FOR 5 SECONDS. THE FACEPLATE WILL LIGHT BLUE, THE POINTER WILL STEP FIVE TIMES AND RETURN TO ZERO. TO SELECT THE PROGRAM, USE THE RIGHT (UP) OR LEFT (DOWN) BUTTON TO MOVE THE POINTER TO DESIRED OPTION.

- \* MOVING POINTER TO ZERO (0) SETTING SELECTS MONITORING ECU FUEL INJECTION
- \* MOVING THE POINTER TO HIGHEST TEMPERATURE SETTING (300F) SELECTS MONITORING A TEMPERATURE SENSOR.
- \* PRESS THE CENTER (MODE) BUTTON TO SAVE THE PROGRAM.



### OPTION: RESTORE FACTORY DEFAULT:

While in **PEAK PLAYBACK**, press and hold the center and right buttons for five seconds. Dial pointer will step five times and return to zero. This will erase all user-programmed calibrations and settings, and return to **NORMAL/DIAL BRIGHTNESS**.

PEAK

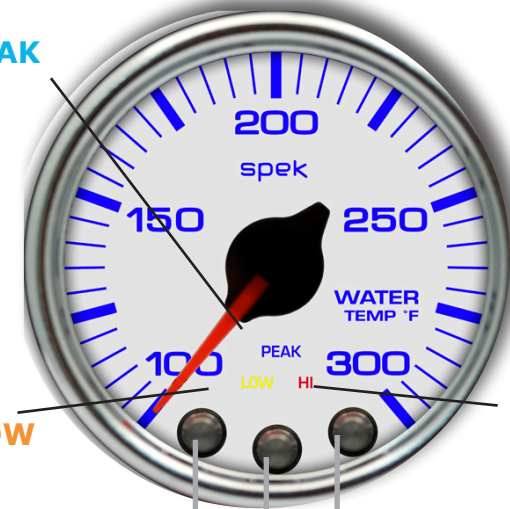

LOW

HI

Down Button

Mode Button

Up Button



### OPTION A: DEMO MODE:

WHILE IN **COLOR SCHEME**, press and hold the center and right buttons for five seconds. Dial will scroll through the seven color schemes. The **HI**, **LOW** and **PEAK** will light, and the dial pointer will move. Press the center button to return to **NORMAL/DIAL BRIGHTNESS**.



### OPTION A: POINTER BRIGHTNESS:

Press CENTER and LEFT buttons for five (5) seconds to enter pointer brightness mode. The dial pointer will start to flash and point to the upper right.



### OPTION: POINTER BRIGHTNESS:

Press LEFT or RIGHT buttons to adjust pointer brightness. Press the CENTER burron to save and return to **NORMAL/DIAL BRIGHTNESS**.

## Wiring Installation Instructions for : Temperature 2 1/16" Spek Pro Professional Racing Gauge

### SPEK PRO™ TEMPERATURE GAUGE

#### PACKAGE CONTAINS:

- Temperature Gauge
- 1/8" electric sender
- Wiring Harness
- Mounting Cup

### FEATURES:

#### SPEK PERFORMANCE GAUGE FEATURES:

- INTELLIGENT ELECTRICAL GAUGES.
- GAUGES ARE PROGRAMMED THROUGH COMMAND KEYS ON FACEPLATE.
- STEPPER MOTOR DRIVES THE GAUGE POINTER OVER A 280 DEGREE SWEEP.
- WIDE-ANGLE-DIAL™ HAS A 15% LARGER VIEWING AREA ON A 2 1/16" GAUGE.
- PROGRAMMABLE 7 COLOR DIAL AND **RED** POINTER ILLUMINATION.
- OPTIONAL OUTPUT CONTROL MODULE.

### INSTALLATION INSTRUCTIONS:

1. DISCONNECT NEGATIVE (-) BATTERY TERMINAL.
2. VARIOUS MOUNTING SOLUTIONS ARE PRESENTED BY PROPARTS, LLC ON THEIR WEBSITE AT **www.ProPartsLLc.com**. DASH INSTALLATION: SELECT LOCATION IN THE DASH TO MOUNT GAUGE AND CUT A 2 1/16" HOLE. USE A FILE TO INCREASE THE HOLE SIZE IF REQUIRED. BE SURE THERE IS SUFFICIENT ROOM BEHIND THE HOLE FOR THE METER CASE AND THE CONNECTORS YOU WILL USE.
3. IF A SUITABLE HOLE IN THE FIRE WALL IS NOT AVAILABLE, CUT AN 11/16 HOLE.
4. Grommet MUST BE CUT TO PERMIT INSTALLATION OF WIRING HARNESS. (SEE DIAGRAM 1)
5. INSTALL THE GROMMET AND MOUNTING CUP ON THE WIRING HARNESS AS SHOWN IN **DIAGRAM 1**. GROMMET IS FOR THE HOLE IN THE FIREWALL.
6. DO NOT CONNECT WIRING HARNESS TO THE GAUGE UNTIL THE OTHER CONNECTIONS HAVE BEEN MADE AND TESTED.

## Wiring Installation Instructions for : Temperature 2 1/16" Spek Pro Professional Racing Gauge

- 7** SELECT A LOCATION FOR MOUNTING THE SENDER. SENSOR MUST BE IMMERSSED IN FLUID 3-6 MM FOR AN ACCURATE READING.
- 8** OIL, DIFFERENTIAL AND TRANSMISSION SENDERS MAY REQUIRE A MOUNTING HOLE BE DRILLED AND A 1/4" NPTF ADAPTER WELDED IN PAN..
- 9** CLEAN THREADS IN MOUNTING FITTING AND SCREW SENDER UNIT IN HAND TIGHT.
- 10** USE TEFLON SEALING COMPOUND. TAPE IS NOT RECOMMENDED.
- 11** WITH WRENCH, TIGHTEN SENDER INTO BLOCK UNTIL SECURE. DO NOT OVER TIGHTEN. TEST ALL FITTINGS FOR LEAKS.
- 12** CONNECT THE **RED** (+12 VOLT SUPPLY) WIRE TO "ON" CIRCUIT THAT GETS POWER WHEN THE IGNITION IS TURNED ON. THIS CIRCUIT MUST BE FUSED BEFORE THE IGNITION SWITCH (1 AMP, 3 AG FAST ACTING LITTLEFUSE® #312001 OR EQUIVALENT).
- 13** CONNECT THE **BLACK** WIRE TO A GOOD GROUNDING POINT ON THE CAR'S CHASSIS.
- 14** CONNECT THE **WHITE** WIRE TO THE DIMMER VOLTAGE GOING TO THE DASH LIGHTS. THIS WILL CAUSE THE METER BRIGHTNESS TO TRACK THE BRIGHTNESS OF THE REST OF THE INDICATORS.
- 15** PLUG THE SENDER WIRING HARNESS INTO THE PACKARD FITTING ON THE SENSOR.
- 16** PLUG THE WIRING HARNESS INTO THE GAUGE AND MOUNT IN POD OR DASH. USE CARE WHEN CONNECTING OR DISCONNECTING THE WIRING HARNESS. PULL OUT EACH PACKARD FITTING CONNECTOR WHILE PRESSING THE LOCK OF THE CONNECTOR FIRMLY.
- 17** FOR DASH MOUNTING, ATTACH MOUNTING CUP OVER THE BACK OF THE GAUGE AND HAND TIGHTEN. DO NOT OVER-TIGHTEN. MOUNT CUP BEFORE INSTALLING GROMMET. FAILURE TO DO SO WILL TWIST WIRES CAUSING A SHORT CIRCUIT.
- 18** POWER UP THE GAUGE AND INSPECT ALL CONNECTIONS. IF GAUGE IS OPERATING NORMAL, PROCEED TO "PROGRAMMING MANUAL."

### TROUBLESHOOTING:

- 1** IF THE SENSOR PROBE IS DISCONNECTED FROM THE WIRING HARNESS, THE DIAL WILL FLASH "**RED**" FOR SIXTY SECONDS. THE DIAL WILL THEN RETURN TO NORMAL BUT THE HI AND LOW LED'S WILL REMAIN LIT UNTIL THE CONDITION IS CORRECTED.
- 2** DO NOT USE ANY SENDER ADAPTER THAT WOULD REDUCE THE SENSORS IMMERSION IN FLUID. FOR ACCURACY, SENSOR SHOULD BE 3-6MM IMMERSSED IN THE FLUID IT IS MONITORING.
- 3** SENSOR CAN BE TESTED WITH AN OHM METER. CONNECT POSITIVE LEADS TO THE SENDER TERMINAL AND TO THE NEGATIVE GROUND. READING SHOULD BE AS FOLLOWS:  
  
TEMPERATURE SENDER COLD (65°F).....4 KΩ (OHM)  
TEMPERATURE SENDER HOT (250°F).....240 KΩ (OHM)



# Wiring Installation Instructions for : Temperature 2 1/16" Spek Pro Professional Racing Gauge

**DIAGRAM 1**

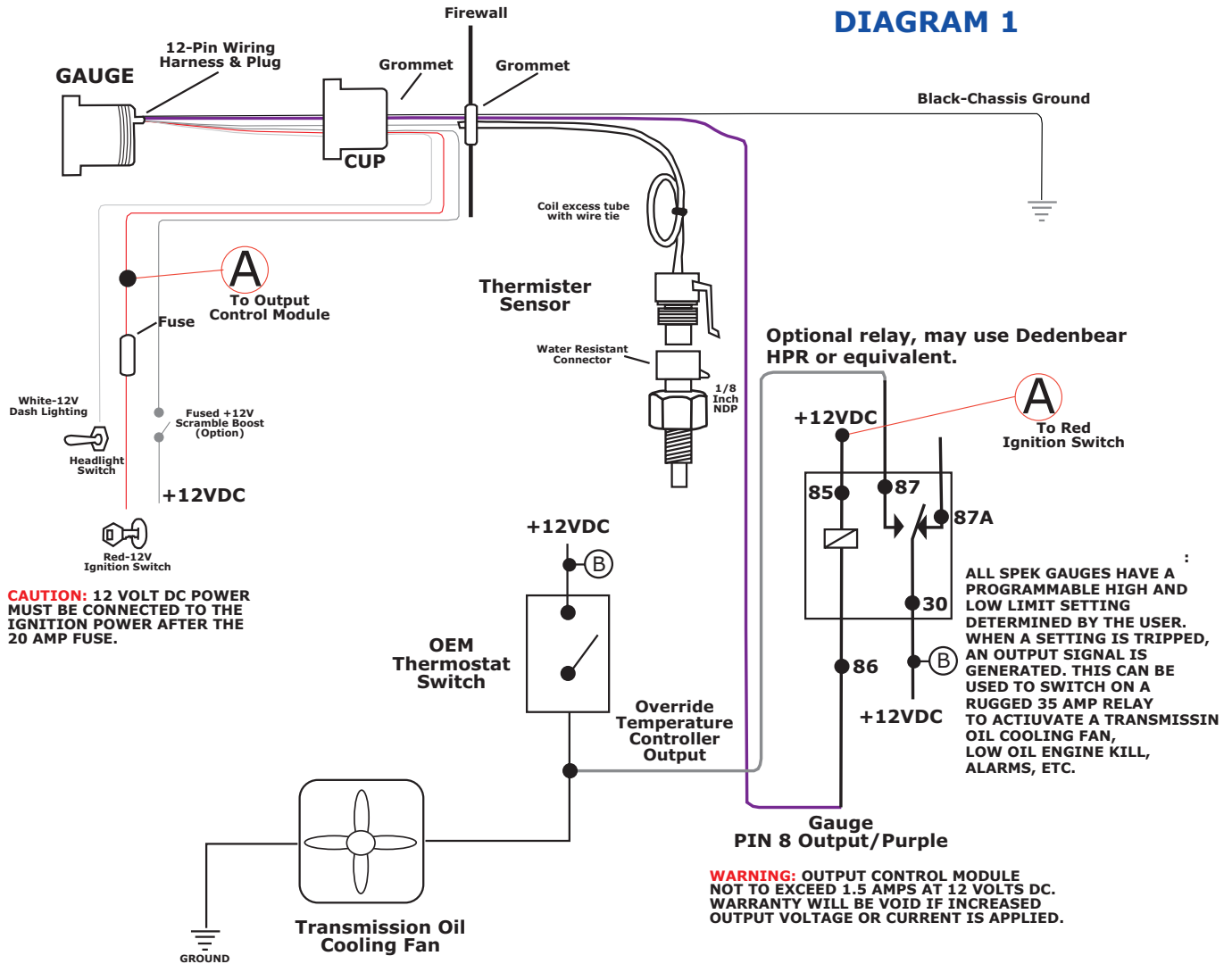

PATENTED WIDE ANGLE DIAL  
FOR SUPERIOR VISIBILITY  
U.S PATENT #7,278,749

# Wiring Installation Instructions for : Temperature 2 1/16" Spek Pro Professional Racing Gauge

## WIRING FOR 2 1/16" SPEK TEMPERATURE GAUGE

DIAGRAM 2

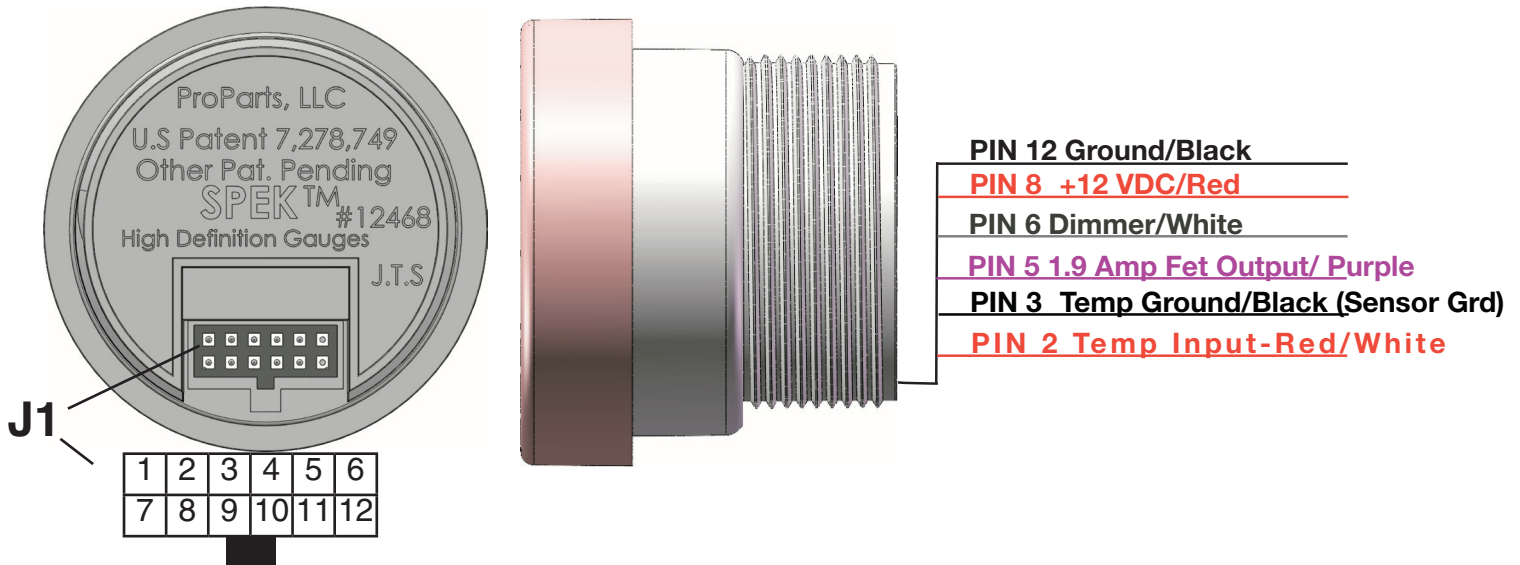

THERE ARE THREE SECTIONS TO THIS MANUAL: WIRING INSTRUCTIONS, PROGRAMMING INSTRUCTIONS AND FLOW CHART PROGRAMMING INSTRUCTIONS. PLEASE READ EACH SECTION CAREFULLY BEFORE ATTEMPTING TO INSTALL OR OPERATE THIS PRODUCT.

**WARNING:**

- ALL INSTRUCTIONS IN THIS MANUAL MUST BE FOLLOWED TO INSURE SAFE INSTALLATION AND OPERATION OF THIS PRODUCT.
- NEVER DISASSEMBLE MODIFY OR TAMPER WITH THIS PRODUCT. THIS COULD CAUSE DAMAGE AND MAKE THEM UNSAFE TO USE. TAMPERING WITH THE PRODUCT WILL VOID THE LIMITED WARRANTY.
- INSTALLATION MUST BE PERFORMED BY AN EXPERIENCED AUTOMOTIVE TECHNICIAN.
- INSTALLER MUST USE SAFETY GLASSES.
- DISCONNECT THE NEGATIVE BATTERY TERMINAL BEFORE BEGINNING INSTALLATION. PROPARTS LLC IS NOT RESPONSIBLE FOR DAMAGE TO ENGINE, VEHICLE OR UNIT CAUSED BY ELECTRICAL SHORTS.
- DURING INSTALLATION, DO NOT INTERFERE WITH ANY EXISTING CONNECTIONS OR WIRES.
- ALL ELECTRICAL CONNECTIONS USE SOLDER LESS CONNECTORS AND INSULATE ALL CONNECTIONS WITH ELECTRICAL TAPE.
- AVOID WIRING NEAR ENGINE, EXHAUST SYSTEM, TURBINE OR ANY AREA THAT MAY RESULT IN DAMAGE.
- DISCONTINUE USE OF THE PRODUCT IF SMOKE OR A STRANGE ODOR IS PRESENT.

**CAUTION**

- PROPARTS LLC IS NOT RESPONSIBLE FOR INCORRECT INSTALLATION OR PROGRAMMING

## **Wiring Installation Instructions for : Temperature 2 1/16" Spek Pro Professional Racing Gauge**

### **OF SPEK™ GAUGES OR CONTROLLERS.**

- **SPEK™ GAUGES AND CONTROLLERS ARE DESIGNED FOR 12V DC ELECTRICAL SYSTEMS WITH A NEGATIVE GROUND.**
- **DO NOT ADJUST THE GAUGES OR GAUGE PROGRAM WHILE DRIVING**
- **OBEY ALL RULES AND REGULATIONS OF HIGHWAY AND STREET DRIVING.**
- **INSTALL SENSOR AND WIRE AWAY FROM HIGH HEAT AND / OR VIBRATION AREAS.**
- **USE CARE WHEN CONNECTING OR DISCONNECTING THE WIRING HARNESS. PULL OUT EACH CONNECTOR WHILE PRESSING THE LOCK OF THE CONNECTOR FIRMLY.**
- **IF THE BATTERY TERMINAL IS DISCONNECTED, THE AUDIO, CLOCK AND OTHER MEMORY DATA MAY BE LOST. THE NECESSARY DATA WILL HAVE TO BE RESET AFTER INSTALL.**