

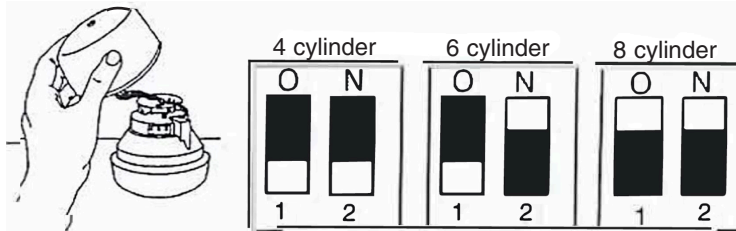

Engine Cylinder Adjustments

This tachometer is factory calibrated for 8 cylinder engines. For operation on 4 or 6 cylinder engines, a switch adjustment must be made.

1. Remove cup by placing the tachometer face down on a smooth surface. Remove the phillips screw on the back and gently lift the cup off to expose the circuit board. Take care not to pull on the wires.
2. Locate the switch on the circuit board. Move each of the two switches to the proper cylinder selection according to the diagram illustration on the right.
 - 4 Cyl. - Both switches down
 - 6 Cyl. - Switch #1 down. Switch #2 up
 - 8 Cyl. - Both switches up
3. Replace the case on the tach with mounting bracket at the bottom (make sure the wires are clear of the screw hole).
4. Replace the screw.



Wiring Connect the tachometer wires as shown. The wiring diagram shown is a typical installation.

Figure A

For Distributor type ignitions with no aftermarket ignition box.

CAUTION!

As a safety precaution, the red wire of this product should be fused before connecting to the 12V ignition switch. We recommend using a 3 AMP automotive type fuse.

Note to Consumer

Some models contain a "lifetime" sealed light. It is not consumer serviceable. In the unlikely event the light should ever fail, the tach must be returned to AutoMeter for a light replacement.

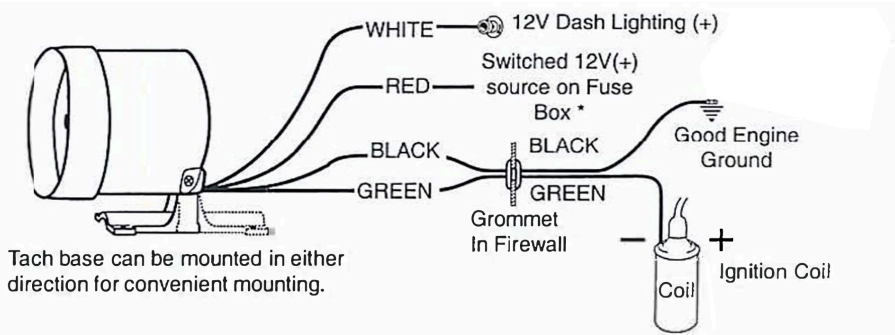

Figure B

For aftermarket ignitions that provide a tach terminal or tach output wire.

Important

Warranty will be void if connected to coil on an ignition that provides its own tachometer output wire or terminal, such as MSD, Crane, etc.

CAUTION!

As a safety precaution, the red wire of this product should be fused before connecting to the 12V ignition switch. We recommend using a 3 AMP automotive type fuse.

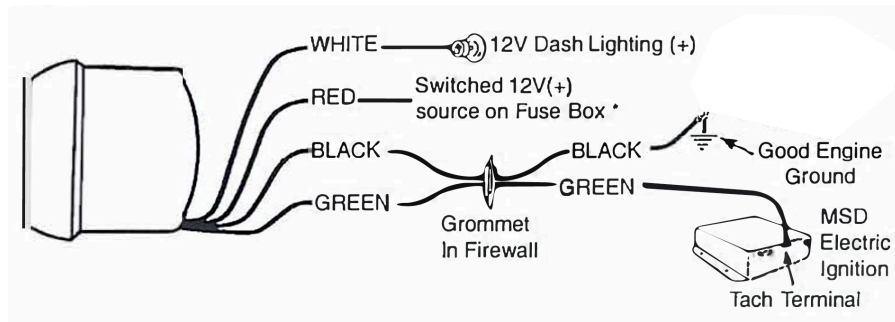
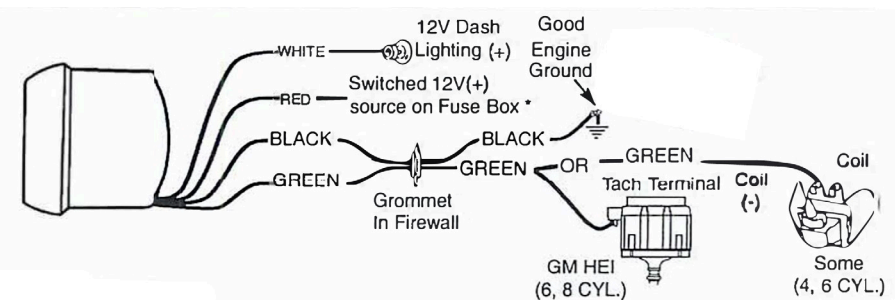

Figure C

For GM HEI ignitions

CAUTION!

As a safety precaution, the red wire of this product should be fused before connecting to the 12V ignition switch. We recommend using a 3 AMP automotive type fuse.



* Optional: Wire to a switched 12V source with an in line fuse.

Shift-Lite Operation

(Models 2302, 2309, 233908, & 233909)

To operate the Auto gage Shift-Lite tachometer, first determine your engine's shift point for max. horsepower (for example, 3400 rpm). Turn on the power to the tach. Set the desired RPM by turning the adjust knob on the back of the tach, the pointer will move. Stop when it reaches the desired shift point. Turn the power off. The tach will now use the selected shift point, until set differently. When the tachometer reaches your set point, the red shift light will come on. It will stay on until the engine speed drops below the set point.

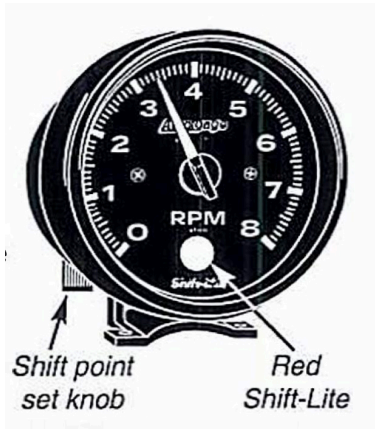

Special Note

Your tachometer operates off your car's ignition. Problems such as bouncing ignition points, bad plug wires, defective ignition capacitor, or arcing distributor cap may cause erratic readings on your tachometer. To insure steady, accurate readings, make necessary adjustments to your ignition.

Use a 12 volt 2 watt bulb (AutoMeter Bulb #161) as a replacement bulb for night lighting.

- Note: If the engine is running, the shift point can't be set.

- Note: The shift point setting can be checked anytime the vehicle is powered on with the engine off. Turn the ignition on and the shift point setting will show on the dial.



Model 2309

Shift-Lite Cover

Models 2309, 233908, & 233909

Important: The Tachometer Shift-Lite is designed for maximum brightness during daylight use. This may be too bright for night driving. A yellow bulb cover is included to reduce the brightness for night driving.



Dial Rotation

The dial can be rotated for optimum legibility. Loosen the screw at the center back of the cup, turn the bezel, then re-tighten the screw. Rotate dial no more than 180° in either direction. If binding is felt, remove cup and reposition wires.



Mounting

1. Mount the tachometer base in the desired location with the screws provided. When selecting a location for the base, be sure the tachometer can be adjusted to the proper position.



Models 2300, 2301, 2303, & 2304

2a. Mount tachometer to base. Place tachometer on mounting base and slide screw through base and tachometer, tighten on opposite side with washer and nut provided.

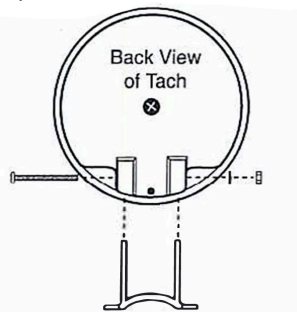

Models 2302, 2309, 233908, 233909

2a. Mount tachometer to base. Place tachometer on mounting base and slide the screw through the lock washer and flat washer as shown, then slide through the base and the tachometer. Screw tightly into preinstalled nut on the other side.

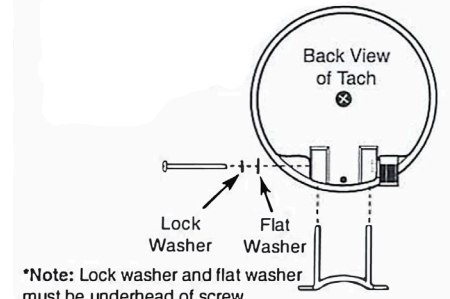

*Note: Lock washer and flat washer must be underhead of screw.