

INSTALLATION INSTRUCTIONS ELITE DIGITAL BOOST/VAC PRESSURE GAUGE

Models 6758-CB, 6758-PH, 6758-SC, 6758-UL

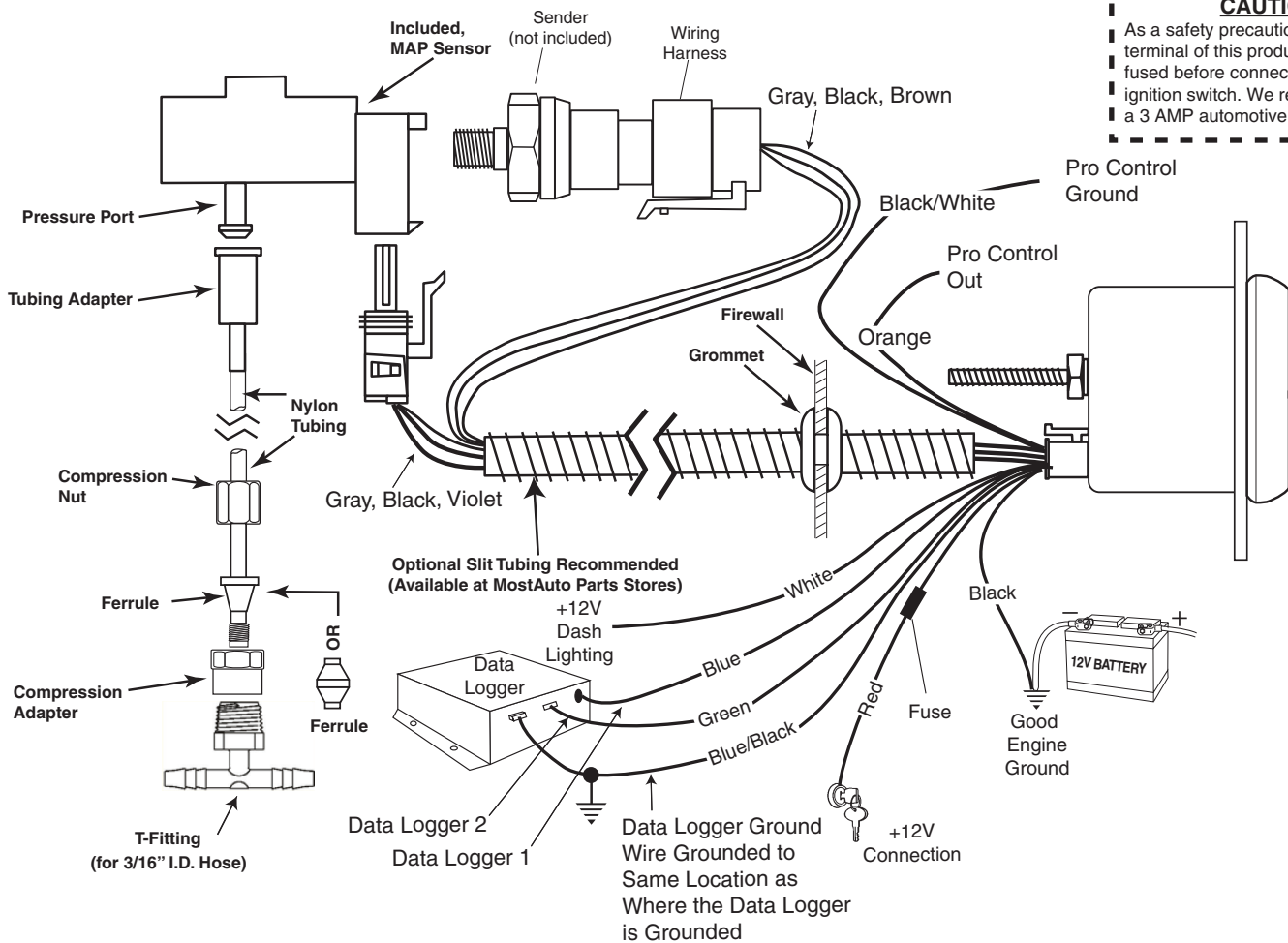

CAUTION!
As a safety precaution, the +12V terminal of this product should be fused before connecting to the 12V ignition switch. We recommend using a 3 AMP automotive type fuse.

A T-fitting for 1/4" I.D. hose is available as model #3276.

NOTE: MAP Sensor should be mounted with PRESSURE PORT facing down. Failure to do so could result in inaccurate readings due to condensation in the line. (Bracket fabrication may be required.)

Connections

Red	+12V	Orange	Pro Control Out
Black	Good Engine Ground	Black/White	Pro Control Ground
White	Dash Lighting	Blue	Data Logger 1
Gray, Black, Violet	Boost Vac Sender	Green	Data Logger 2
Gray, Black, Brown	Pressure Sender	Blue/Black	Data Logger 1 and 2 Ground

Installation

1. Check that you have all parts required for installation, and the engine is cool.
2. Disconnect the negative (-) battery cable.
3. Gauge mounts in a 2 1/16" hole. Use supplied brackets and nuts to secure gauge to dash.
4. Drill 1" diameter hole where wires pass through sheet metal (such as firewall) and install rubber grommet provided. (Grommet will require slit.)
5. Securely mount the MAP sensor to the firewall or inner fender with pressure port facing down. (Bracket fabrication may be required.)
6. Install T-Fitting in a manifold vacuum hose. Attach one end of the nylon tubing to the T-Fitting using the compression adapter. Connect the other end of the nylon tubing to the MAP sensor with the tubing adapter. A T-fitting for 1/4" I.D. hose is available as model #3276.
7. Connect the white wire to dash lighting or switchable 12v light source. Digital display will dim when power is applied.
8. Connect the red power wire to a switched +12 volt source **that maintains power during engine cranking**. Most vehicles break the electrical connection to accessories while the engine is being started. If the boost gauge is connected to one of these circuits, the auto zero function will not work properly and inaccurate readings will result. To determine whether a switched source maintains power during starting, look for electrical accessories in the vehicle that remain on while the engine is being started. Connect the red power wire to the same circuit that powers one of these accessories.

Installation - Fuel & Boost Pressure

WARNING:

The fuel system is pressurized and often retains this pressure for an extended period of time. Properly vent your fuel system before installing the fuel pressure sender. If you are not familiar with the proper method of venting, you **MUST** have this done by an experienced mechanic.

1. Check that you have all parts required for installation, and the engine is cool.
2. Disconnect the negative (-) battery cable.
3. Gauge mounts in a 2 1/16" hole. Use supplied brackets and nuts to secure gauge to dash.
4. Drill 1" diameter hole where wires pass through sheet metal (such as firewall) and install rubber grommet provided. (Grommet will require slit.)
5. Connect the white wire to dash lighting or switchable 12v light source, the red wire to switched +12V source and the black wire to ground. (see diagram for details) Digital display will dim when power is applied to white wire.

WARNING: Not compatible with Nitromethane, Methanol, or 100% MTBE.

6. For fuel pressure gauge, install the 1/8" NPT pressure sender into the fuel system (See warning in next column). If unit is to be installed on a high vibration application such as a full race engine or engine capable of high RPM, it is strongly recommended that the sender be remote mounted to either the fenderwell or firewall, to insulate from vibration. **Failure to remote-locate pressure senders on such an application could result in gauge failure and potential damage to vehicle and/or operator injury.** Braided stainless steel lines are sold separately by AutoMeter, and can be used to accomplish this.
7. Reconnect negative (-) battery cable.

NOTE: Test all fittings and hoses for any leakage. If any leaks are detected, determine the cause of the leak and repair. Do not operate vehicle if any leaks are detected.

CAUTION:

If you will be working with the fuel system, take care to insure no sparks or flames occur. Do not smoke while installing the fuel pressure sender.

Installation - Nitrous Pressure

1. Check that you have all parts required for installation, and the engine is cool.
2. Disconnect the negative (-) battery cable.
3. Gauge mounts in a 2 1/16" hole. Use supplied brackets and nuts to secure gauge to dash.
4. Drill 1" diameter hole where wires pass through sheet metal (such as firewall) and install rubber grommet provided.
5. Connect the white wire to dash lighting or switchable 12v light source, the red wire to switched +12V source and the black wire to ground. (see diagram for details) Digital display will dim when power is applied to white wire.
6. **Make sure the nitrous bottle valve is closed and there is no pressure in the system.**
7. Remove the main nitrous feed line from the bottle or the nitrous solenoid. Install on in-line gauge adapter either on the nitrous bottle or nitrous solenoid. Re-install the main nitrous feed line. Install pressure sender and wiring harness.
8. Open the nitrous bottle valve.

NOTE: Test all fittings and hoses for any leakage. If any leaks are detected, determine the cause of the leak and repair. Do not operate vehicle if any leaks are detected.

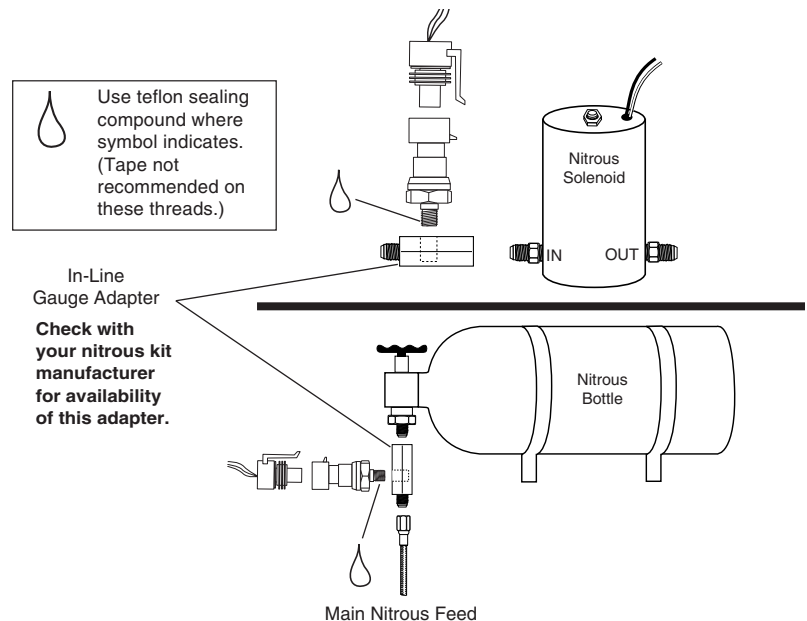

Menu Options:

There are many features provided by your Auto Meter Elite Digital Boost/Vac Pressure gauge. Use the left (-) button to navigate through the following options in order:

- Peak Recall – Digit display will show "P"
- Differential Mode – Digit display will show "diF"
- Pro Control 1 Set – Digit display will show "PC1"
- Pro Control 2 Set – Digit display will show "PC2"
- Pro Control Active State – Digit display will show "PCA"
- Pressure Channel 1 Display Assignment – Digit display will show "CH1"
- Pressure Channel 2 Display Assignment – Digit display will show "CH2"
- Channel 1 Alarm Set – Digit display will show "A1"
- Channel 2 Alarm Set – Digit display will show "A2"
- Channel 2 Pressure Sender Set – Digit display will show "P2"
- Select English or Metric Units for the Digit Display – Digit display will show "uni"
- Barometric Compensation – Digit display will show "b c"
- Gauge Firmware Revision – Digit display will show a the firmware revision number.

Power-Up

When power is applied to the gauge, the digit display will light with "8.8.8." and the entire bargraph display will light for one second. Then the gauge will begin normal operation and display real time sender readings.

Sender Range Set

Channel 2 of the Elite Digital Boost/Vac Pressure Gauge works with many different AutoMeter pressure sender ranges. This can also be used with other pressure senders as long as the output from the sender is 0.5V to 4.5V (low to high). This kit includes one AutoMeter model 2246 0-100 PSI sender. To set this to the proper range for the attached sender, press the left button repeatedly until the digit display shows "P2". Then press the right button. Use the right (+) and left (-) buttons until the number shown on the display is the full scale pressure of the sender on Channel 2. Values above 999 are shown with a decimal. For example, 1600 PSI would be shown as "1.60" on the display. When the desired number is shown, wait for the display to flash this number rapidly, then "S c". It will continue to do this until the left button is pressed to save the setting, or the right button is pressed to cancel the setting.

Channel Assignment

The Elite Digital Boost/Vac Pressure Gauge has two displays, one shows digits, the other is a radial bar graph consisting of 30 green LED's. To assign Channel 1 to one or both displays, press the left button repeatedly until the digit display shows "CH1". Then press the right button. The digit display will show "dig", "bAr", "bth", or "---". To assign Channel 1 to the digit display, press the left button until the digit display shows "dig". When the desired number is shown, wait for the display to flash this number rapidly, then "S c". It will continue to do this until the left button is pressed to save the setting, or the right button is pressed to cancel the setting. Saving the setting when the digit display shows "bAr" assigns Channel 1 to the bar graph display. Saving the setting when the digit display shows "bth" assigns Channel 1 to the digit display and the bar graph display. Saving the setting when the digit display shows "---" assigns Channel 1 to neither display. To assign Channel 2 to a display, press the left button repeatedly until the digit display shows "CH1". Then press the right button. Assign Channel 2 in the same manner as Channel 1.

If Channel 1, the Boost/Vac channel, is assigned to the bar graph display, no LED's will be lit if the gauge measures 0 boost, 0 vacuum. If a positive, boost pressure is measured, LED's starting at about 10 o'clock and moving clockwise will be lit. 10 LED's will be lit if the gauge reads 15 PSI. 20 LED's will be lit if the gauge reads 30 PSI. If a vacuum is measured, LED's starting at about 10 o'clock and moving counterclockwise will be lit. 5 LED's will be lit if the gauge reads 15 in.-Hg. 10 LED's will be lit if the gauge reads 30 in.-Hg. If Channel 2, the pressure channel, is assigned to the bar graph display, and a 100 PSI pressure sender is used, no LED's will be lit if the gauge reads 0 PSI. If a greater pressure is measured, LED's starting at bottom left of the dial and moving clockwise will be lit. 15 LED's will be lit if the gauge reads 50 PSI. 30 LED's will be lit if the gauge reads 100 PSI. If Channel 1, the Boost/Vac channel, is assigned to the digit display, a number with a minus sign displays vacuum in In. - Hg. A number without a minus sign displays boost pressure in PSI.

Available AutoMeter Pressure Senders

2229 - 0-60	2245 - 0-15
2239 - 0-30	2246 - 0-100
2240 - 0-1600	

Peak Recall

To view pressure peaks, press the left button. The digit display will show "P". Press the right button. The digit display and bar graph display will show the highest pressure values measured by the gauge. After 3 seconds the gauge will return to normal operation. Pressing the right button while the peaks are still being shown will clear the peaks. The display will show "---", then the gauge will return to normal operation.

Pro Control On Set

The Pro Control Output wire supplies ground when activated. It is recommended to use a relay switch such as the Dedenbear HPR or equivalent. To set the pressure level that will activate the Pro Control Output, press the left button until the digit display shows "PC1" or "PC2", depending on the pressure channel it's being set for. Press the right button. The digit display will show "on". Press the right button again. Use the right (+) and left (-) buttons until the number shown on the display is the desired value of pressure. Values above 999 are shown with a decimal. For example, 1600 psi would be shown as "1.60" on the display. When the desired number is shown, wait for the display to flash this number rapidly, then "S c". It will continue to do this until the left button is pressed to save the setting, or the right button is pressed to cancel the setting.

It is possible to set Pro Control values for both channels. If channel 1 exceeds it's Pro Control set point or channel 2 is below its set point, the Pro Control Output will activate.

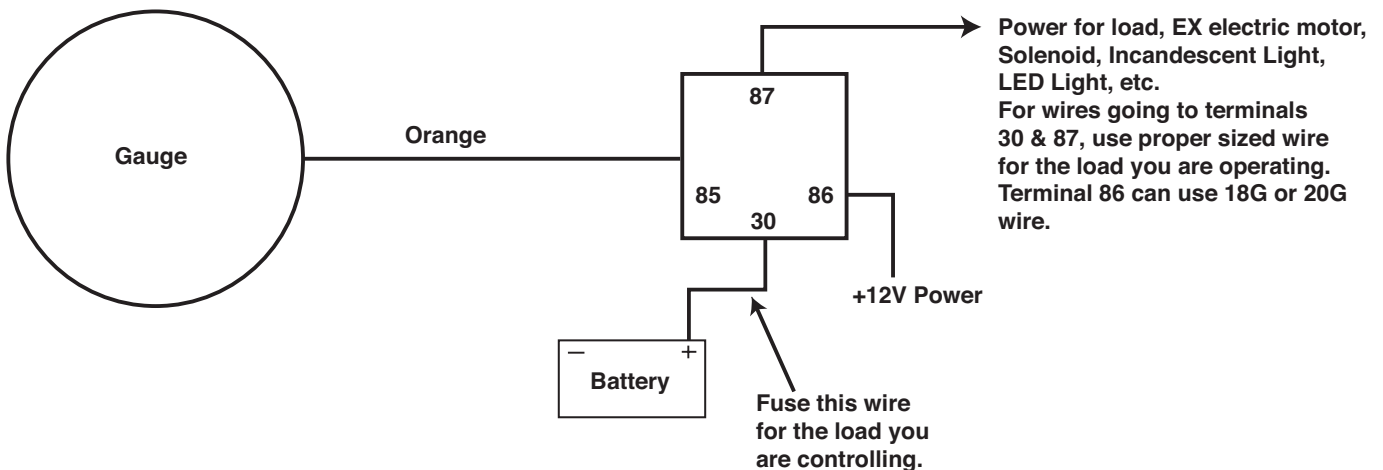

Pro Control Off Set

If it is desired to have the Pro Control Output deactivate at a different pressure than it activates, press the left button until the digit display shows "PC1" or "PC2", depending on the pressure channel it's being set for. Press the right button. The digit display will show "on". Press the left button. The digit display will show "OFF". Press the right button again. Use the right (+) and left (-) buttons until the number shown on the display is the desired value of pressure. When the desired number is shown, wait for the display to flash this number rapidly, then "S c". It will continue to do this until the left button is pressed to save the setting, or the right button is pressed to cancel the setting.

Pro Control Active State

This will allow the user to change the Pro Control on channel 2 to activate above the set value and turn off below the set value. To change this, press the left button until the digit display shows "PCA", then press the right button. The digit display will show "PCL". Press the left button. The digit display will show "PCH". Press the right button. Channel 1, the Boost/Vac channel with continue to activate it's Pro Control when it's Pro Control value is exceeded.

Alarm Set

This Alarm feature will cause the digit display or the bar graph display to flash rapidly if the pressure channel shown on that display exceeds a user set value. To set the pressure level that will activate the Alarm, press the left button until the digit display shows "A1" or "A2", depending on the pressure channel it's being set for. Press the right button. Use the right (+) and left (-) buttons until the number shown on the display is the desired value of pressure. Values above 999 are shown with a decimal. For example, 1600 PSI would be shown as "1.60" on the display. When the desired number is shown, wait for the display to flash this number rapidly, then "S c". It will continue to do this until the left button is pressed to save the setting, or the right button is pressed to cancel the setting.

Differential Mode

This will allow the user to view the difference in pressure of the two channels on the digital display. The bar graph display will continue to show whichever channel was assigned to it. To turn on Differential Mode, press the left button until the digit display shows "diF", then press the right button. Press the left button until the digit display shows "On", then press the right button.

English or Metric Units

This will allow the user to view the pressure value shown on the digit display in BAR instead of psi. To change this, press the left button until the digit display shows "uni", then press the right button. The digit display will show "PSI". Press the left button. The digit display will show "bAr". Press the right button. Pressure will now be displayed in BAR. The Boost/Vac channel will show vacuum in Cm – Hg. The bar graph display is not affected by this. If a 100 PSI sender is used on this, all 30 LED's will light at 100 PSI.

Barometric Compensation

If barometric compensation is set to "On", the pressure shown on the gauge is compensated for altitude by a second pressure sensor inside the gauge. At higher altitudes, the displayed pressure is increased to compensate for atmospheric pressure. If set to "OFF", the pressure shown on the gauge is referenced to standard atmospheric pressure, regardless of altitude. To set this, press the left button until "b c" is displayed and then press the right button. Press the left button to toggle between "On" and "OFF". Press the right button to confirm your selection. The display will flash the new setting.

Data Logger Output

The AutoMeter Elite Digital Boost/Vac Pressure gauge has a signal output for each channel for supplying information to a Data Logger or engine management system. The signal provided is a linear 0-5v output. On the Boost/Vac channel, the Data Logger will output 0.0 volts for a complete vacuum. The Data Logger will output 1.67 volts for a measured pressure of 0 PSI (no vacuum, no boost) and 5.00 volts for a measured pressure of 30 PSI.

To calculate the measured pressure from the voltage output:

$$\text{PSI} = (\text{Voltage Out} * 9) - 15$$

If the result is negative, the measured vacuum in In.-Hg. Is $\text{PSI} * 2.04$

On the standard pressure channel, the Data Logger will output 0.0 volts for a measured pressure of 0 PSI. It will output 5.0 volts at full scale pressure (100 PSI if set to this in Sender Range Set).

To calculate the measured pressure from the voltage output:

$$\text{PSI} = \text{Maximum Pressure} * (\text{Voltage Out}/5.00)$$