

INSTALLATION INSTRUCTIONS

IN-DASH ELECTRIC TACHOMETER

For Use on Early Model & Most Electronic Ignitions

2650-1165-00 Rev. C



Calibration

IMPORTANT: This tachometer is factory calibrated to operate on 8 cylinder engines. For 4 or 6 cylinder engines, it is necessary to make the proper adjustments to adapt this tachometer to your cylinder range.

Locate the access hole on the back of the tachometer. Move each of the two switches to the proper cylinder selection according to the diagram illustration on the right. Use a small screwdriver or an unwound paper clip to change the switch settings.

NOTE: This tachometer has an air core meter. With power off, it is normal for the pointer to leave zero. When power is applied, the pointer will move to the correct position.

Figure A.

- 8 CYL. (4 pulse)- Both switches up.
- 6 CYL. (3 pulse)- Switch One up, Switch Two down.
- 4 CYL. (2 pulse)- Switch One down, Switch Two up.
- 4 CYL. (1 pulse)- Both switches down.

If you are unsure of your vehicle's pulse(s) per revolution or specific calibration requirements, contact Auto Meter Technical Service Dept. at (866) 248-6357, or go to www.autometer.com/hp/techtips for information.

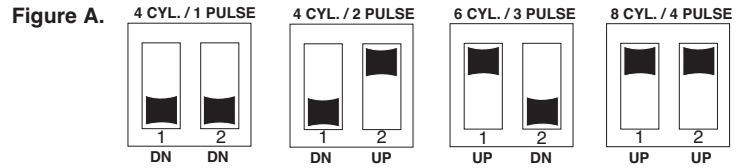

(Angle view through access hole)

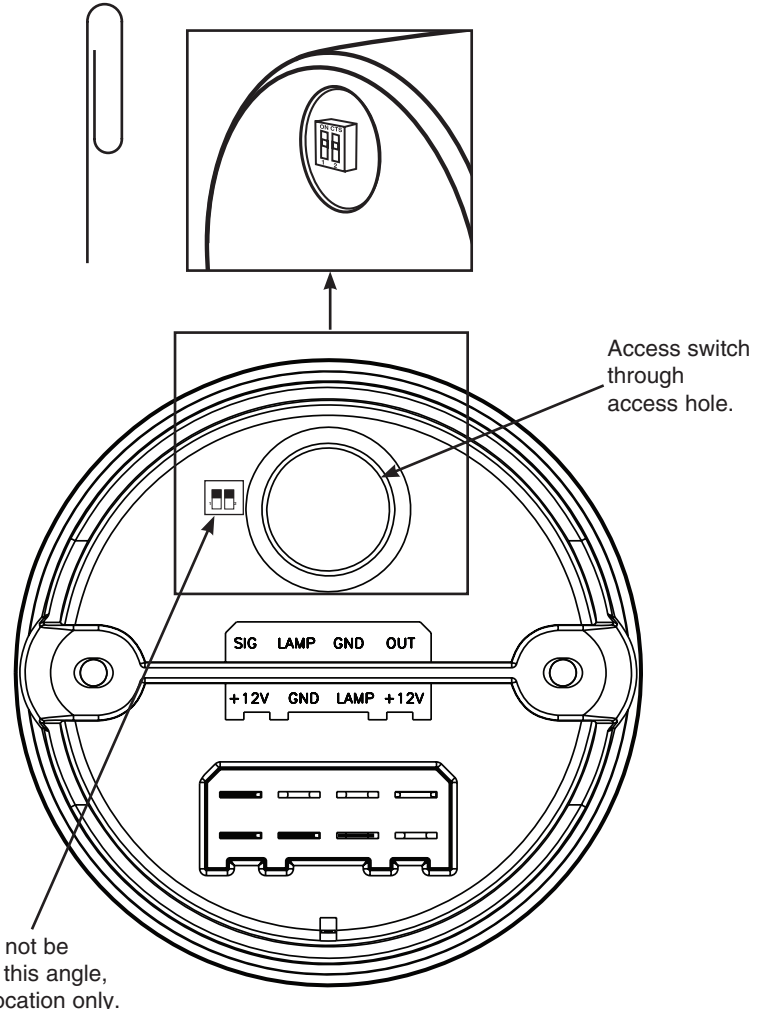

3 3/8" SIZE SHOWN

Lens Cleaning

To prevent scratching the lens when cleaning, use a mild, soapy solution to clean. Wipe lightly with a soft cloth.



Note:

This tachometer operates on most early model ignitions, factory electronic and high performance electronic racing ignitions.

Mounting

1. Mount the 3 $\frac{3}{8}$ " tachometer in a 3 $\frac{3}{8}$ " dia. hole and a 5" tachometer in a 4-5/8" dia. hole in the dashboard.
(Be careful not to cut the hole too large.)
2. Cut a $\frac{3}{8}$ " dia. hole in the firewall for the tachometer wires. Place a rubber grommet in the hole and route the connector wires through the grommet to the engine compartment.
3. Connect the tachometer wires as shown in the Wiring Section.
4. Secure the tachometer to the dashboard using the provided bracket & hardware.

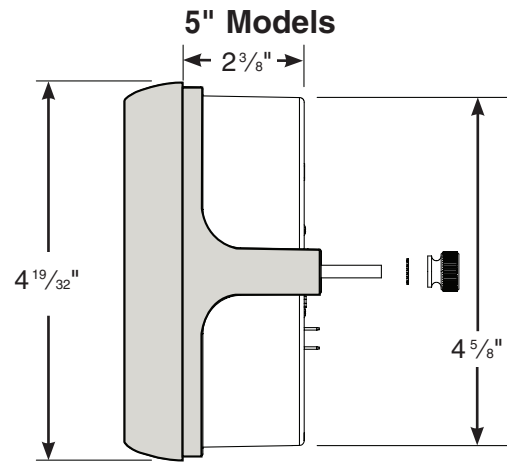
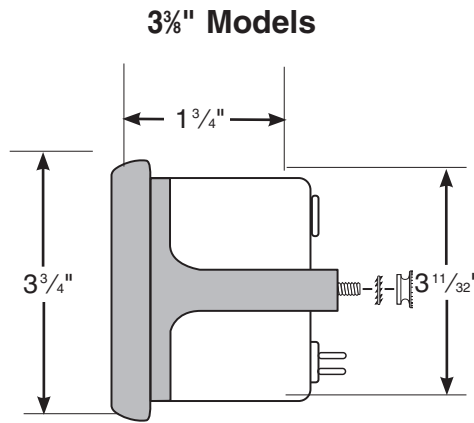

WIRING

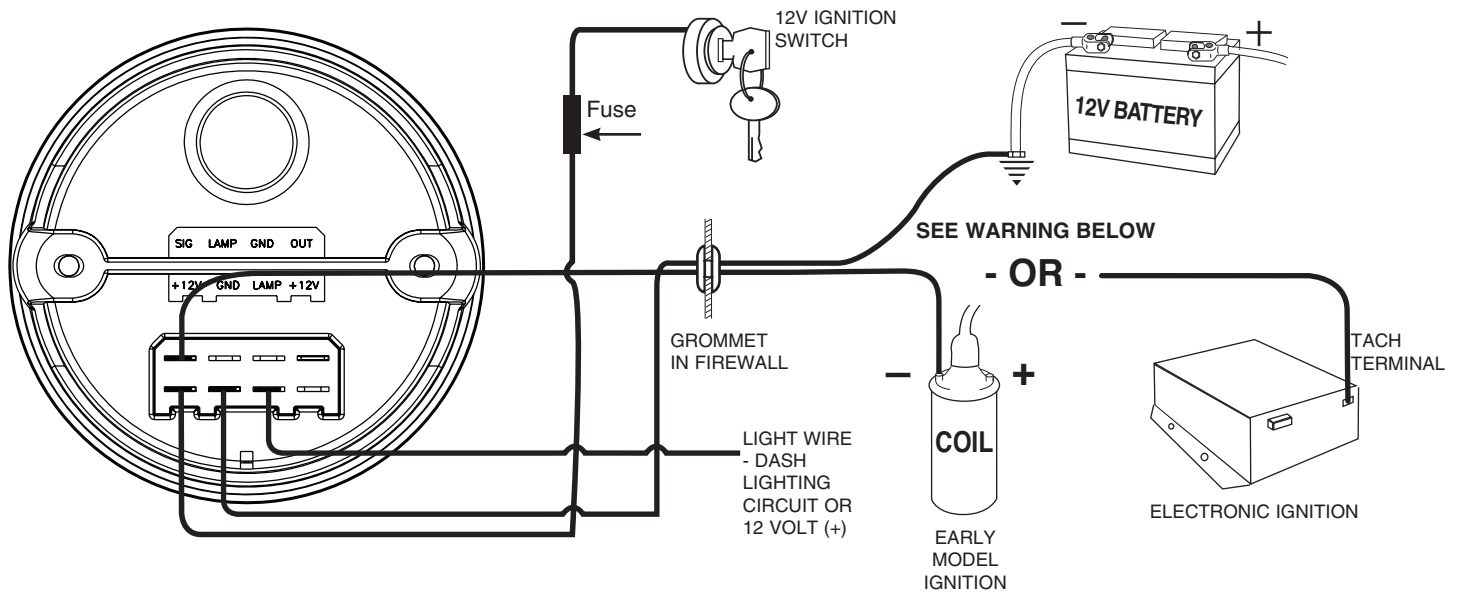

WARNING

Warranty will be void if connected to coil when using an aftermarket ignition box such as, but not limited to products from the following manufacturers: MSD, Crane, Jacobs, Mallory, Holley, Etc.. Prior to installation of your tachometer, check with the ignition box manufacturer for recommended tachometer signal location.

CAUTION!

As a safety precaution, the +12 V terminal of this product should be fused before connecting it to the 12V ignition switch. We recommend using a 3 Amp, automotive fuse or equivalent to help protect this product.