



## INSTALLATION GUIDE: AWE Jeep Wrangler JK Exhaust

THIS GUIDE IS INTENDED FOR THE FOLLOWING PART NUMBERS:

- 3015-21007 AWE Trail Edition Catback Exhaust for Jeep JK/JKU 3.6L
- 3015-32003 AWE Tread Edition Axleback Dual Exhaust for Jeep JK/JKU 3.6L - Chrome Silver Tips
- 3015-33003 AWE Tread Edition Axleback Dual Exhaust for Jeep JK/JKU 3.6L - Diamond Black Tips
- 3015-11005 AWE Resonated Mid Pipe for Jeep JK/JKU 3.6L
- 3020-11005 AWE Non-Resonated Mid Pipe for Jeep JK/JKU 3.6L

Welcome to the AWE family, and congratulations on your purchase of the AWE Exhaust system for the Jeep JL.

Exquisite build quality and craftsmanship, coupled with industry leading performance, distinguish this exhaust system from all others.

# PARTS LIST (TRAIL EDITION)



**INSPECT ALL PARTS PRIOR TO DISASSEMBLY OF VEHICLE; IF DAMAGED OR MISSING, PLEASE CONTACT THE PLACE OF PURCHASE IMMEDIATELY.**

Symbol	Part Number	Description	QTY
	D69	JK Jeep Wrangler 3.6L Inlet Section Resonated	1
	D72	JK Jeep Wrangler 3.6L Extension Tube (JK"U" 4 door)	1
	D76	JK Jeep Wrangler 3.6L Trail Outlet	1
<b>A</b> >>	TAS300	3.00in Accu-Seal, Stainless Steel Band Clamp	3
<b>B</b> >>	TAS250	2.50in (63.5mm) Accu-Seal, Stainless Steel Band Clamp	1
<b>C</b> >>	3910-11012	AWE 1/2" Split Collar Clamp Kit: Includes 9/64 allen wrench and two 1/2" collar clamps	1

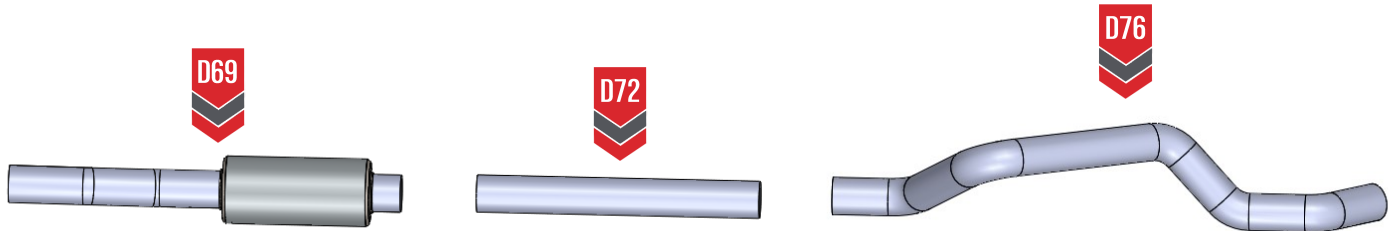
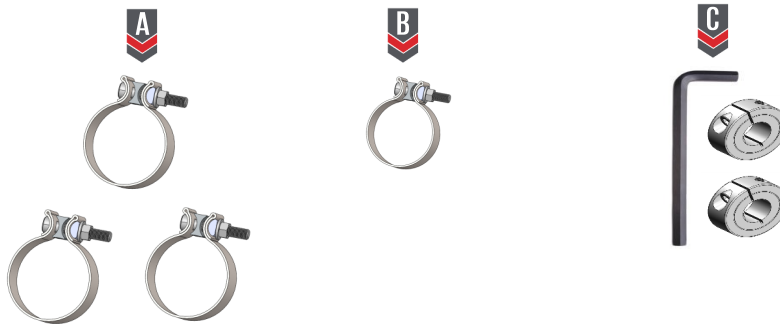

# PARTS LIST (TREAD EDITION AXLEBACK)



**INSPECT ALL PARTS PRIOR TO DISASSEMBLY OF VEHICLE; IF DAMAGED OR MISSING, PLEASE CONTACT THE PLACE OF PURCHASE IMMEDIATELY.**

Symbol	Part Number	Description	QTY
	D73	JK Jeep Wrangler 3.6L Twin HR1 Rear Assembly	1
	D74	JK Jeep Wrangler 3.6L Driver Tip Outlet	1
	D75	JK Jeep Wrangler 3.6L Passenger Tip Outlet	1
<b>A</b> >>	TAS250	2.50in (63.5mm) Accu-Seal, Stainless Steel Band Clamp	3
<b>B</b> >>	3910-11012	Hanger Clamp Kit - 2 Split C-Clamps and 1 Allen Wrench 9/64	1
<b>C</b> >>	BHM8X079SS00C	Barrel Hardware Clamp	2
<b>Chrome Tips - 3015-32003</b>			
<b>D</b> >>	61000078	77mm Inlet, 114mm OD Chrome Plated	2
<b>Black Tips - 3015-33003</b>			
<b>D</b> >>	61000474	77mm Inlet, 114mm OD Black Chrome	2

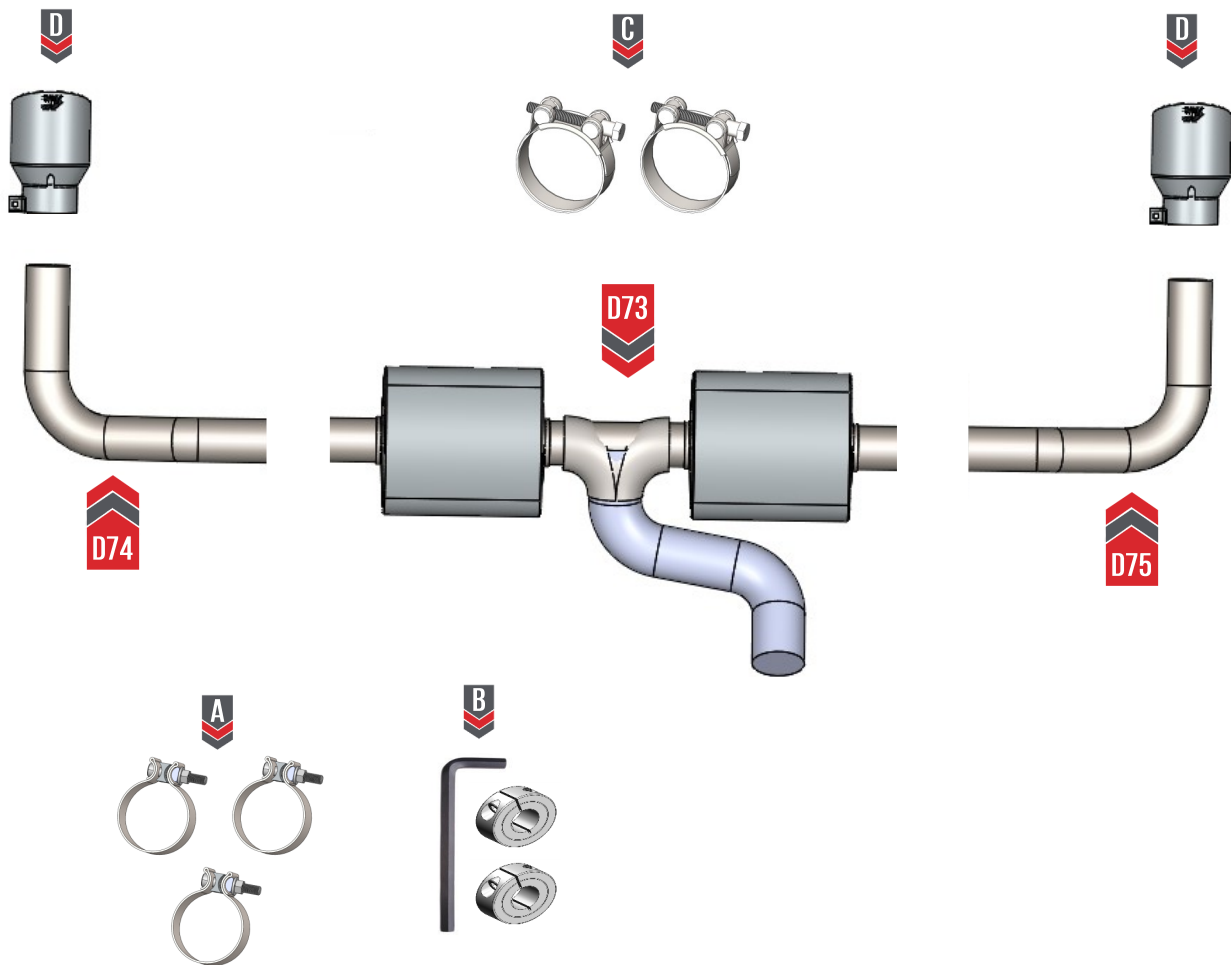

# PARTS LIST (MID PIPE SYSTEMS)



**INSPECT ALL PARTS PRIOR TO DISASSEMBLY OF VEHICLE; IF DAMAGED OR MISSING, PLEASE CONTACT THE PLACE OF PURCHASE IMMEDIATELY.**

Symbol	Part Number	Description	QTY
	D69	JK Jeep Wrangler 3.6L Inlet Section Resonated	1
	D70	JK Jeep Wrangler 3.6L Inlet Section Non Resonated	1
	D71	JK Jeep Wrangler 3.6L Over Axle Tube	1
	D72	JK Jeep Wrangler 3.6L Extension Tube (JK"U" 4 door)	1
<b>A</b> >>	TAS250	2.50in (63.5mm) Accu-Seal, Stainless Steel Band Clamp	1
<b>B</b> >>	TAS300	3.00in Accu-Seal, Stainless Steel Band Clamp	2

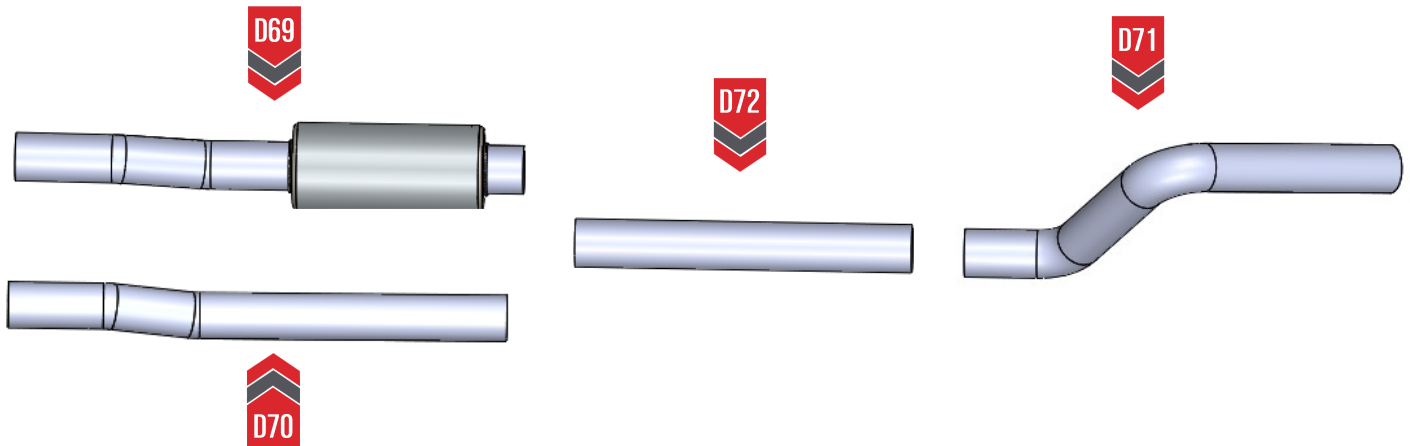



**NOTE:** Always refer to the manufacturer's service manual for precise torque specifications on all OEM fasteners.



**CAUTION:** The exhaust may be **VERY HOT** — allow adequate time for the system to cool down before disassembly. Severe burns and injury will occur if skin comes into contact with a hot exhaust system.

## STEP 1

Start by removing the OE Wrangler exhaust by following the steps, shown in **Figure 1**.



Soak all bolts in penetrant fluid before working.

**Note:** If only installing the axle back system only complete item 4.

1. To begin locate the brace shown at point **(A)**.
2. Remove brace **(A)**, by removing the bolts shown at points **(B)**.
3. Next remove the OE catback exhaust by removing clamps and hangers shown at points **(C)**.
4. Remove the axle back clamp, and hangers marked **(D)**.

**Note:** OE hangers WILL be reused.

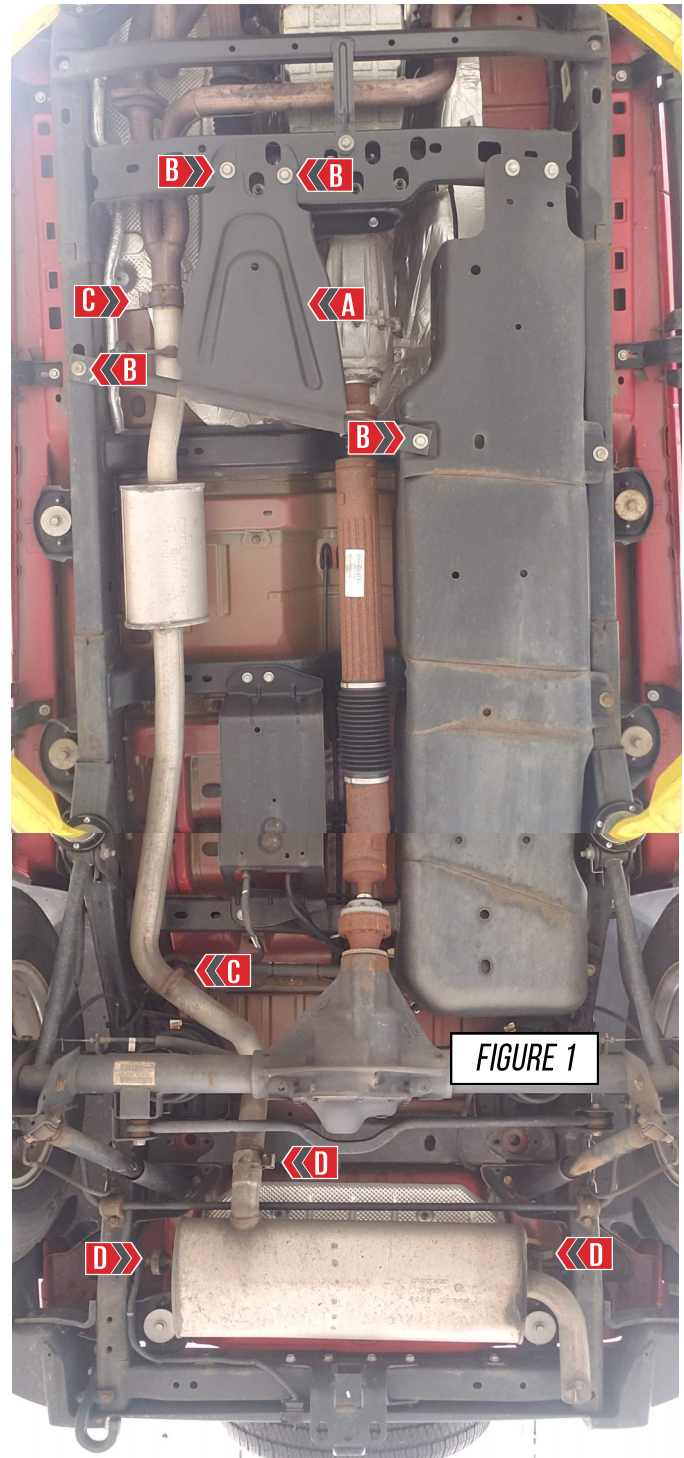

**IF INSTALLING THE AXLE-BACK EXHAUST SYSTEM, SKIP TO STEP 6**



## STEP 2

Install the AWE front pipe (**D69**), at this point just snug the clamp to allow for alignment, as shown in **Figure 2**.

**Note:**

D69– Resonated 3.6L

D70– Non-Resonated 3.6L



## STEP 3

It is crucial to install each section and exhaust band clamps correctly to prevent loose joints, exhaust leaks and rattles.

**Arrow A** shows the expanded pipe and the preinstalled exhaust clamp being brought up to the corresponding pipe.

**Arrow B** shows the overlapping pipe installed correctly over the corresponding pipe.

**Arrow C** shows the exhaust band clamp being brought to the edge of the expanded pipe.



**NOTES:**

- **Do not** fully torque any exhaust clamp until the entire exhaust has been installed and adjusted.
- Torque specification is a **minimum** of 60 ft/lbs

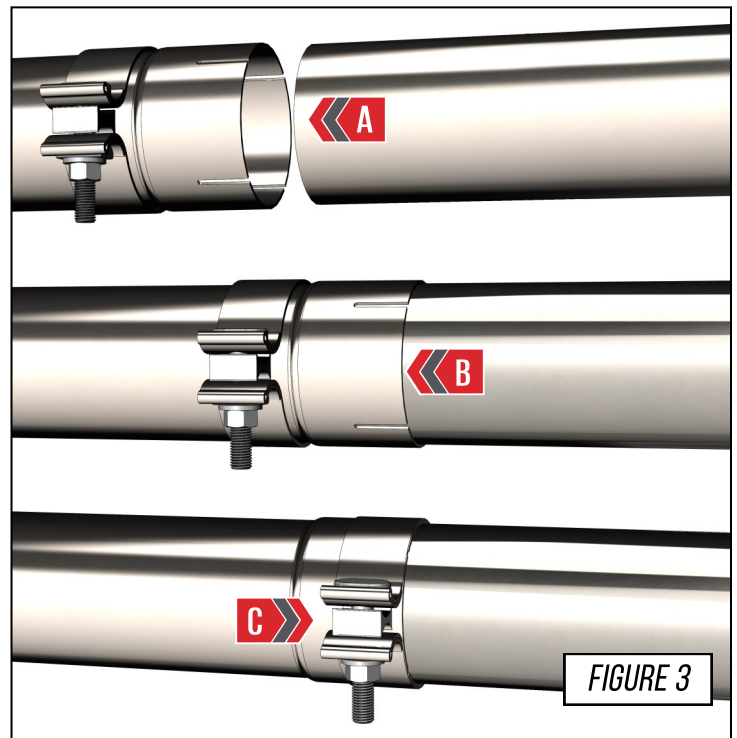

## STEP 4



4 DOOR / JKU - ONLY



If installing the AWE mid pipe onto a 4 door, install the straight tube (D72) onto the AWE front pipe, as shown in **Figure 4**.



2 Door vehicles will NOT use this pipe.

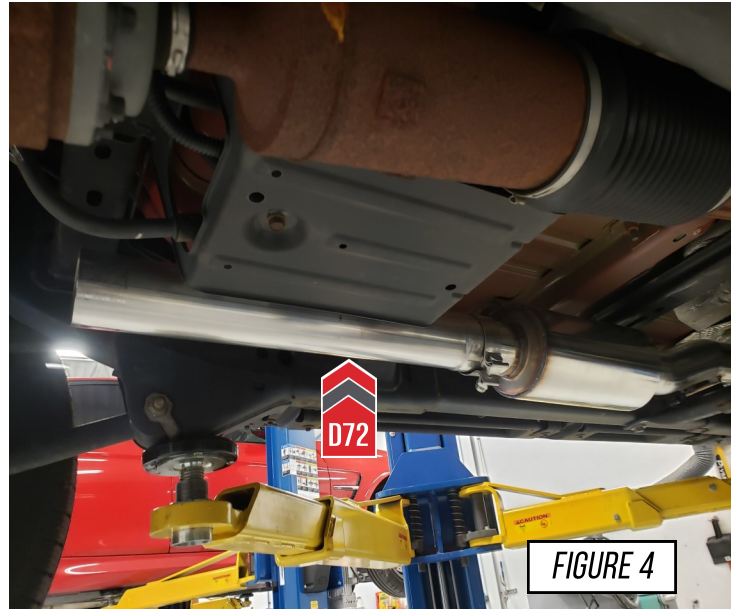

FIGURE 4

## STEP 5

Position the AWE over axle tube (D71) by first inserting the hanger (A), as shown in **Figure 5.1**.

Then slip the AWE tubes together (B), as shown in **Figure 5.2**.



If **ONLY** installing the AWE mid pipe, insert AWE tube into OE axle back and tight all clamps to at least 60 ft-lbs.

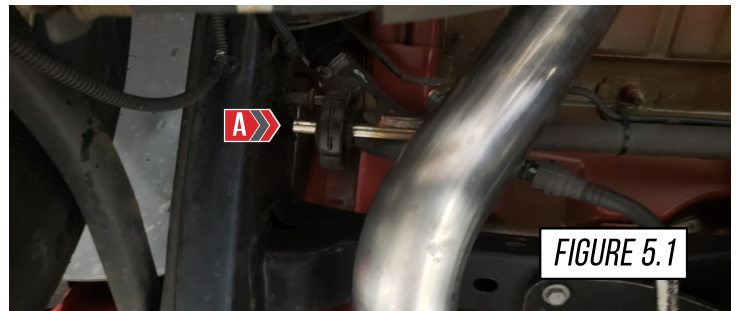

FIGURE 5.1



FIGURE 5.2

ENJOY!



## STEP 6



### AWE Axle back install



With a supplied clamp, insert the AWE axle back inlet onto the mid pipe.

Next insert the hangers as shown in **Figure 6.1**, and **Figure 6.2**

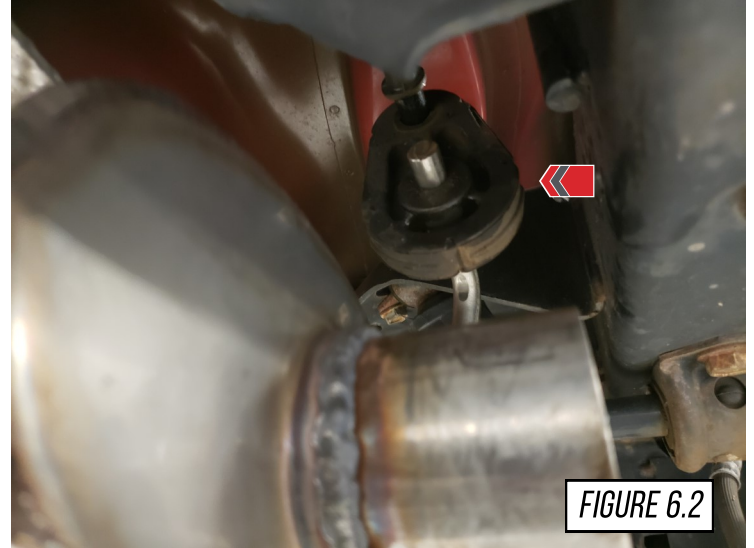
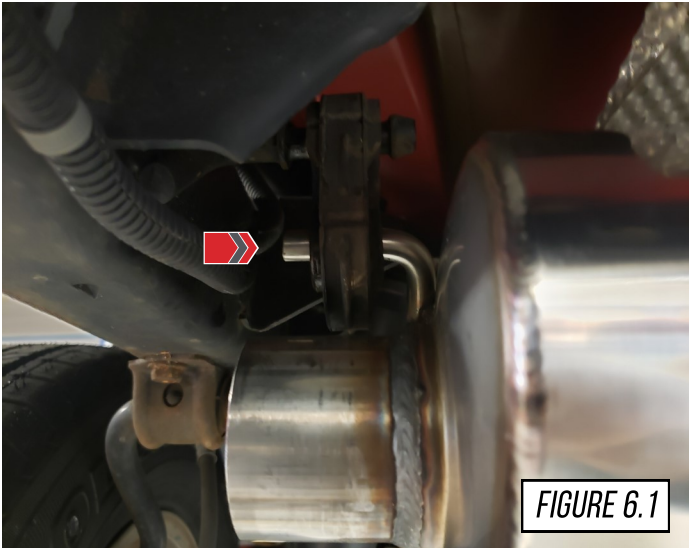

## STEP 7

Snug the clamp enough to keep the pipe from moving while you install, and align the rest of the system, as shown in **Figure 7**.

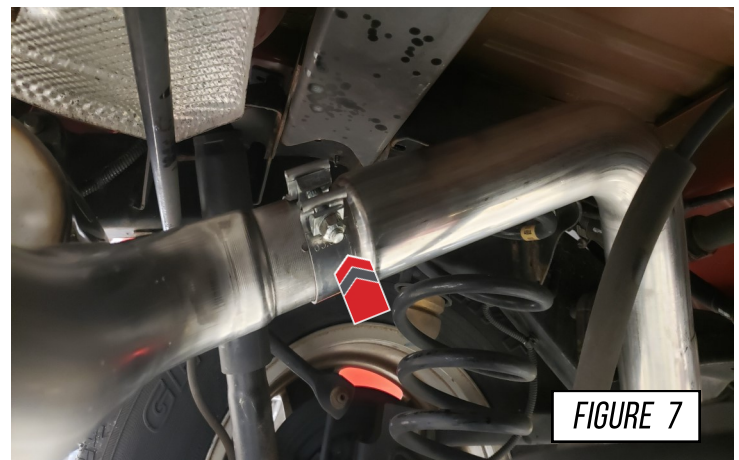

## STEP 8

Install the AWE driver (D75) and passenger (D74) side tubes, with the supplied clamps, as shown in Figure 8-1 and Figure 8-2.

**Note:** Only snug the clamps enough to hold the weight of the tube, while you align the system.



## STEP 9

It is crucial to install each section and exhaust band clamps correctly to prevent loose joints, exhaust leaks and rattles.

**Arrow A** shows the expanded pipe and the preinstalled exhaust clamp being brought up to the corresponding pipe.

**Arrow B** shows the overlapping pipe installed correctly over the corresponding pipe.

**Arrow C** shows the exhaust band clamp being brought to the edge of the expanded pipe.



### NOTES:

- **Do not** fully torque any exhaust clamp until the entire exhaust has been installed and adjusted.
- Torque specification is a **minimum** of 60 ft/lbs

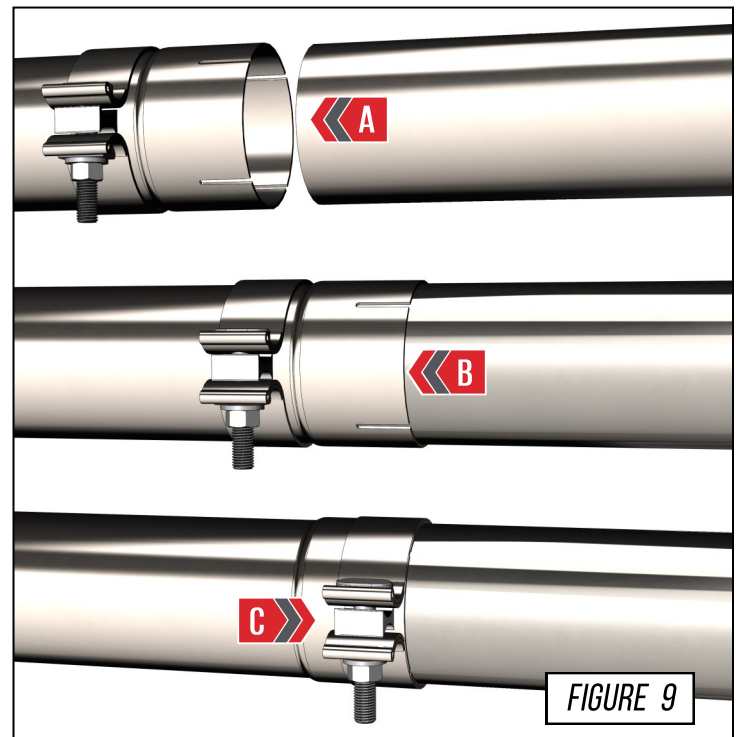

## STEP 10

Install the AWE tips onto the axle back, snug the clamps in place, as shown in **Figure 10-1** and **10-2**.

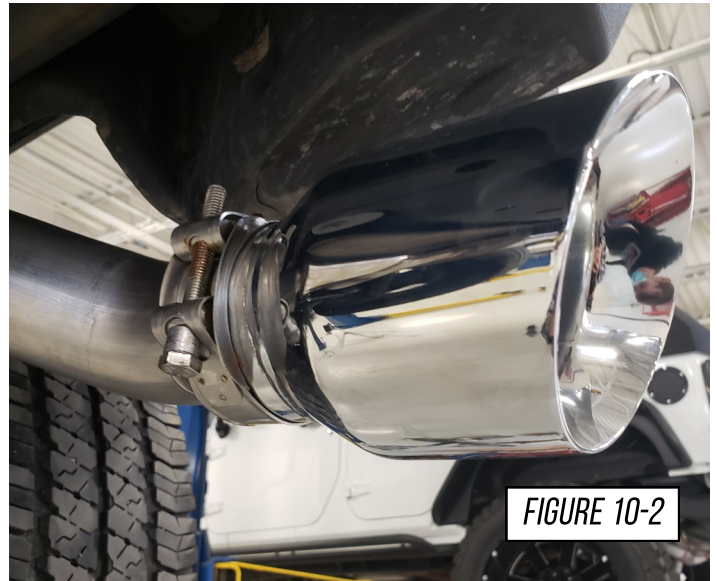

## STEP 11

For the best tip fitment, align the barrel style tip clamp to cover *only* the slot, shown by **Arrow A**

Torque the tip clamp to 18 ft./lbs.



### NOTES:

- It is required to apply anti-seize to the threads to prevent thread binding, shown by **Arrow B**
- It is okay to have the clamp extend beyond the edge of the tip inlet.

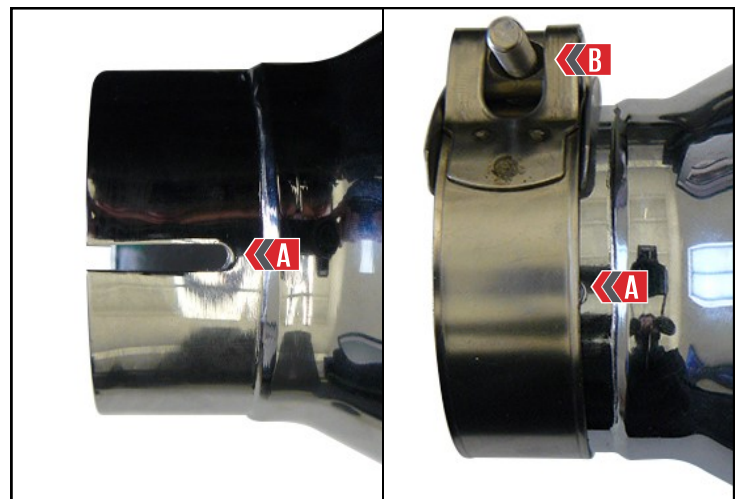

## STEP 12

Check for proper clearance and tighten all clamps in the system to at least 60 ft/lbs, as shown in **Figure 12-1**.

Lastly, reinstall the brace removed in step 1, as shown in **Figure 12-2**

**Note:** It is important to align the HR assembly (**D73**) parallel to the rear cross brace. Shown by arrow **A**

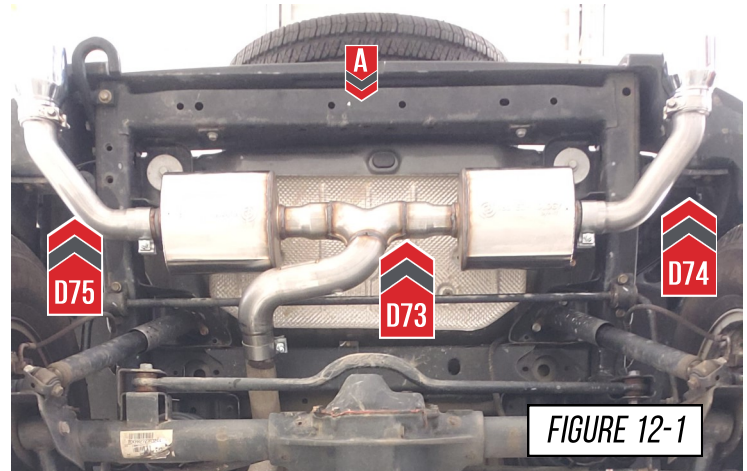

## STEP 13

Lastly, reinstall the brace removed in step 1, as shown in **Figure 13**.

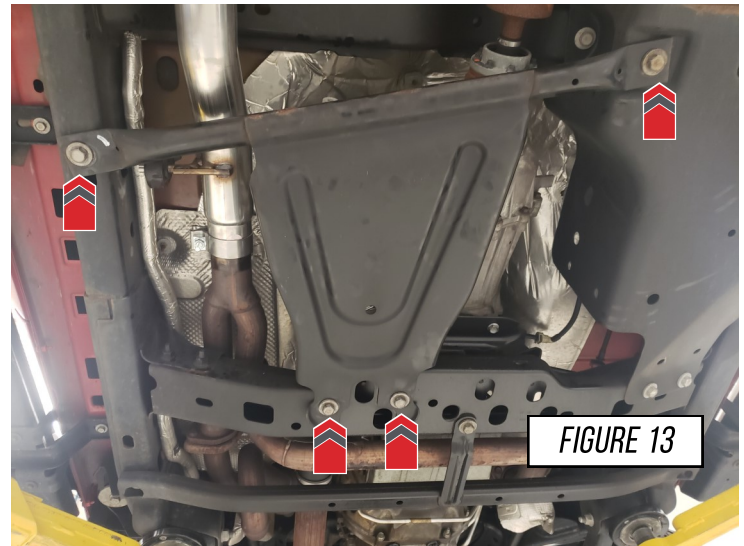

## STEP 14

For the rear sections, hanger bar collar clamps are provided to prevent side to side movement of the exhaust system. After sliding the exhaust hanger bar through the OEM grommet, install the collar clamp on the outside end of the bar as shown in **Figure 14**.

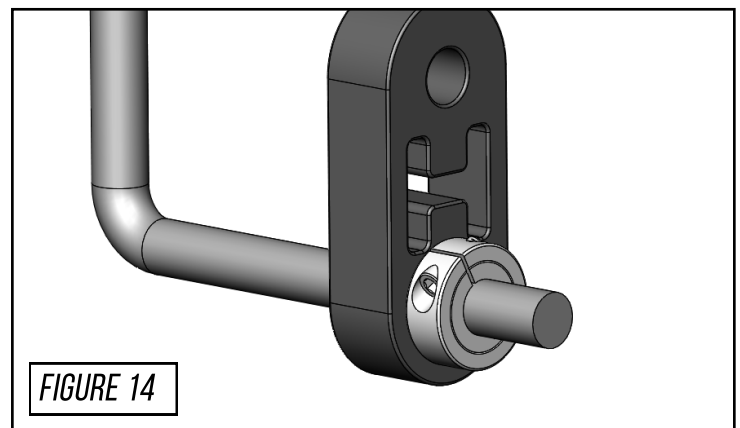

ENJOY!



## STEP 15



AWE Trail Systems ONLY



Install the AWE Trail over axle (**D76**) by installing it from the rear over the axle, as shown in **Figure 15-1**. Then attach the OE rubber hanger (**B**) once attached press the slip fit together, as shown in **Figure 15-2**.

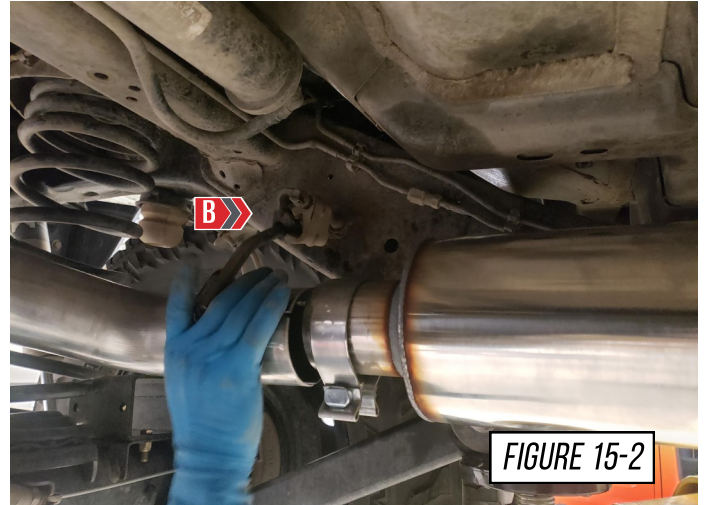
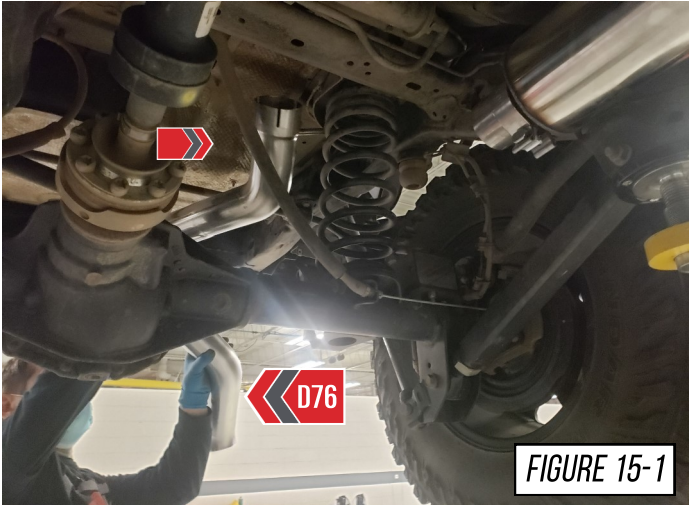

## STEP 16

Make the OE hanger (**A**) and the AWE hanger bar (**B**) as close to parallel as possible, as shown in **Figure 16**. This will help to get correct fitment.

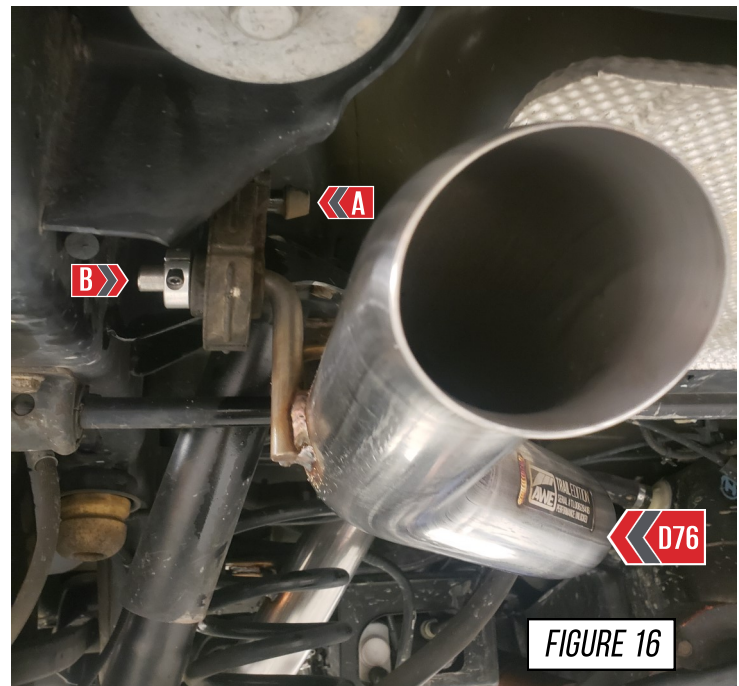

## STEP 17

It is crucial to install each section and exhaust band clamps correctly to prevent loose joints, exhaust leaks and rattles.

**Arrow A** shows the expanded pipe and the preinstalled exhaust clamp being brought up to the corresponding pipe.

**Arrow B** shows the overlapping pipe installed correctly over the corresponding pipe.

**Arrow C** shows the exhaust band clamp being brought to the edge of the expanded pipe.



### NOTES:

- **Do not** fully torque any exhaust clamp until the entire exhaust has been installed and adjusted.
- Torque specification is a **minimum** of 60 ft/lbs

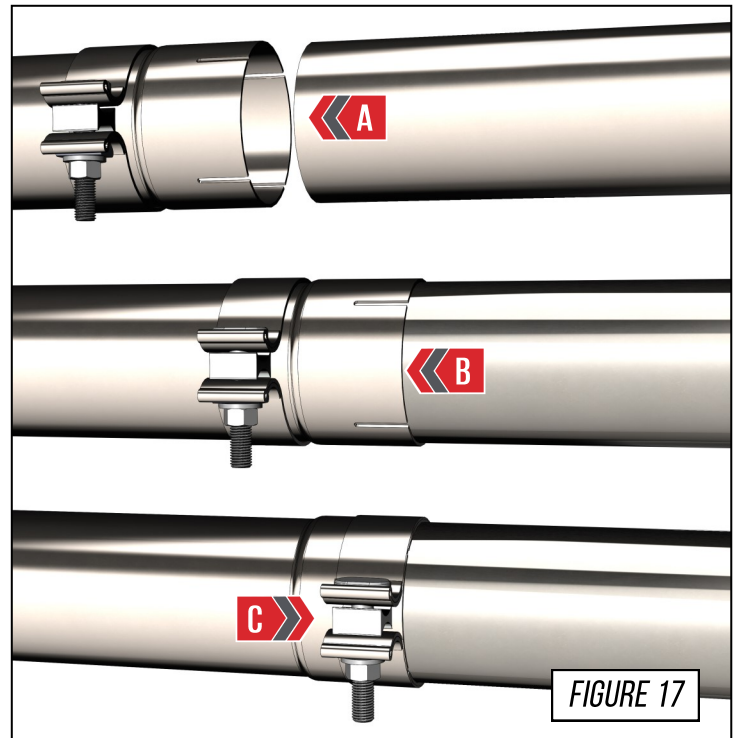

## STEP 18

For the rear sections, hanger bar collar clamps are provided to prevent side to side movement of the exhaust system. After sliding the exhaust hanger bar through the OEM grommet, install the collar clamp on the outside end of the bar as shown in **Figure 18**

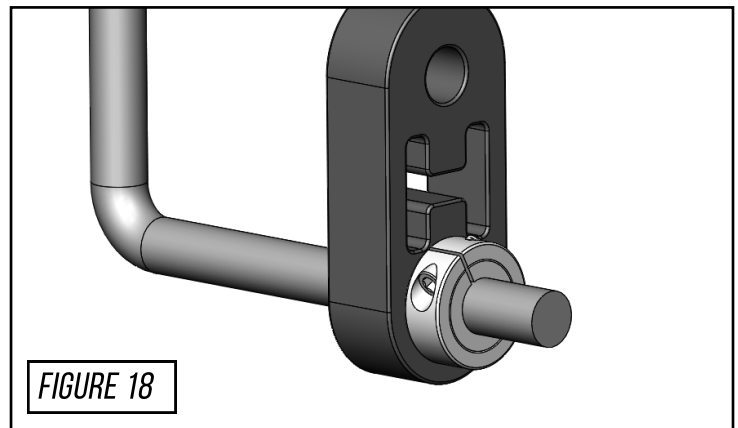

## STEP 19

Reinstall the brace removed in step 1, as shown in **Figure 19**

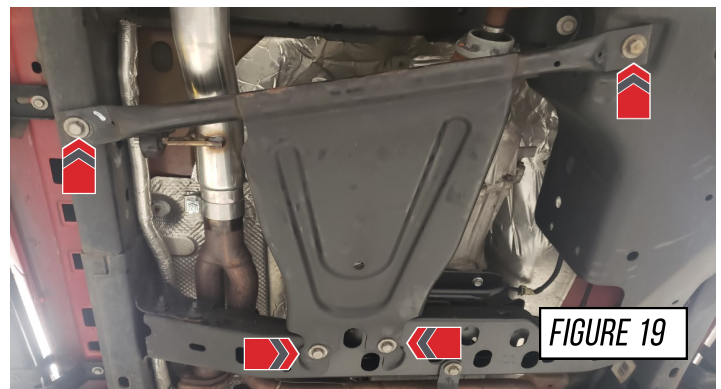

## STEP 20

With the correct fitment, install the supplied hanger clamps onto the 2 locations marked by **(B)**, as shown in **Figure 20**.

Check for proper clearance and tighten all clamps in the system to at least 60 ft/lbs.

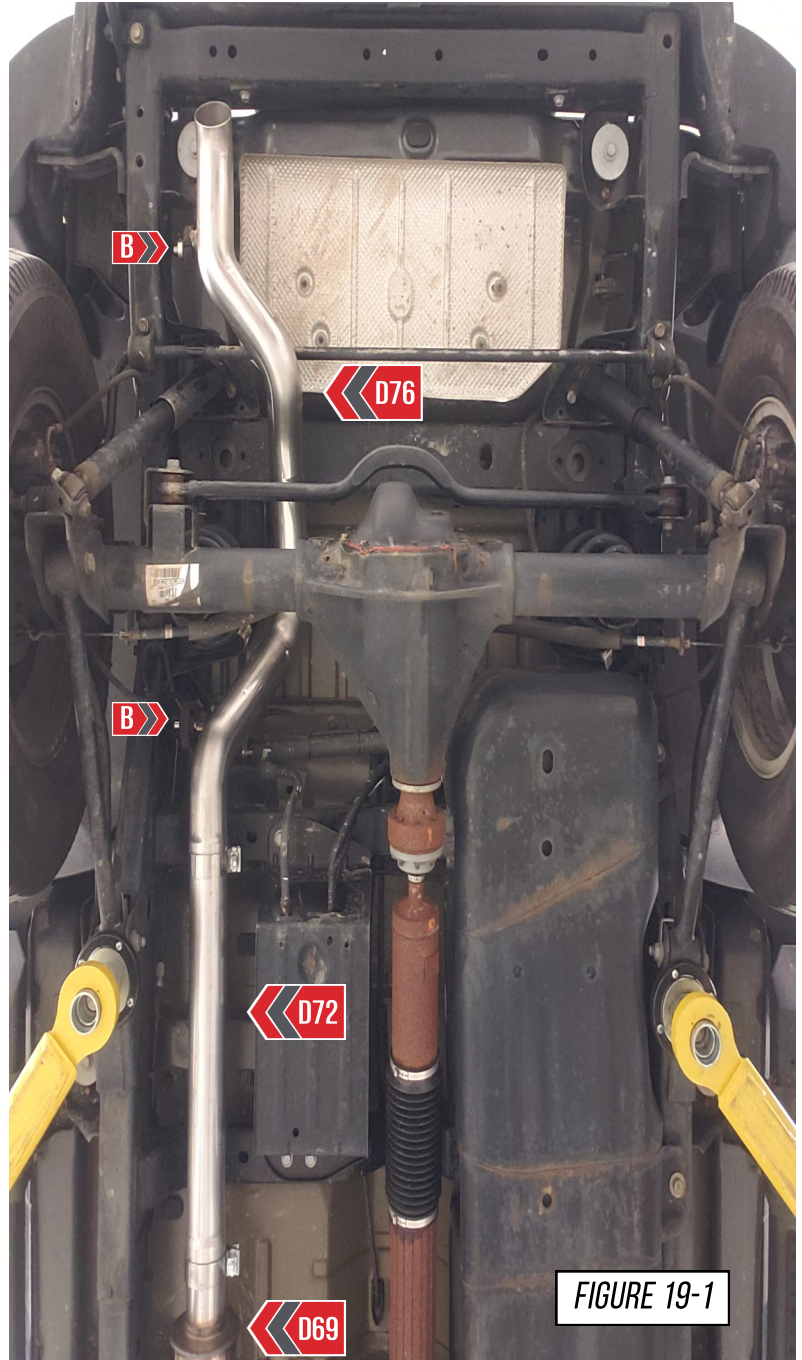

ENJOY!



## TROUBLESHOOTING

Issue	Solution
Exhaust is not fitting correctly	Most fitment issues are due to improperly adjusted exhaust. This includes tip fitments and rattling due to chassis contact. Check out our fitment guide for more installation tips.
Wrong or missing parts	Double check the parts list for your system and compare them with what you received. Fill out our contact form, found below and let us know what parts you need.

## CARE

Once installed properly, your AWE exhaust will provide years of trouble-free performance.

The exhaust volume and sound will settle with usage; 800-1000 miles is required to break-in new exhaust systems.

Also, please note that the rear **180Technology®** resonator has a small drain hole to allow condensation to escape. Water drops from this area are normal.

Periodic cleaning of exhaust tips is necessary to maintain proper finish, especially in areas prone to road salt and caustic deicing solutions. Use a mild soap and water solution or car wax to clean the finish. Avoid using abrasive polishes, as they can scratch the finish.