



INSTALLATION GUIDE: AWE Jeep Gladiator JT Exhaust

For up-to-date information, please visit the products page on AWE-Tuning.com

THIS GUIDE IS INTENDED FOR THE FOLLOWING PART NUMBERS:

- 3015-21001 AWE Trail Edition Catback Exhaust for Jeep JT 3.6L
- 3015-23103 AWE Tread Edition Catback Single-Side Exhaust for Jeep JT 3.6L - Diamond Black Tip
- 3015-33101 AWE Tread Edition Catback Dual Exhaust for Jeep JT 3.6L - Diamond Black Tips

Welcome to the AWE family, and congratulations on your purchase of the AWE Exhaust system for the Jeep Gladiator.

Exquisite build quality and craftsmanship, coupled with industry leading performance, distinguish this exhaust system from all others.

PARTS LIST (AWE TREAD EDITION CATBACK DUAL EXHAUST)



INSPECT ALL PARTS PRIOR TO DISASSEMBLY OF VEHICLE; IF DAMAGED OR MISSING, PLEASE CONTACT THE PLACE OF PURCHASE IMMEDIATELY.

Symbol	Part Number	Description	QTY
	D61	JT Jeep Gladiator 3.6L Flared Inlet 75/76MM with 3X6 Resonator	1
	D62	JT Jeep Gladiator 3.6L Mid Hanger Tube	1
	D63	JT Jeep Gladiator 3.6L HR5 Section	1
	D66	JT Jeep Gladiator 3.6L Dual Outlet (Driver Side)	1
	D67	JT Jeep Gladiator 3.6L Dual Outlet (Passenger Side)	1
A >>	C24	Dual Outlet Universal Hanger DS/PS	1
	610400	Rubber exhaust isolator	1
B >>	3910-11012	Hanger Clamp Kit - 2 Split C-Clamps and 1 Allen Wrench 9/64	1
C >>	TAS300	3.00in Accu-Seal, Stainless Steel Band Clamp	6
D >>	180003BC	5" x 10" Straight cut Tip	2
E >>	110035	Hanger Bracket -Backing 11ga 304SS Machining Included	1
	3910-41022	M8 Bolt and Nut hardware kit	1
	7130K59	7.5 INCH cable ties (Medium)	2

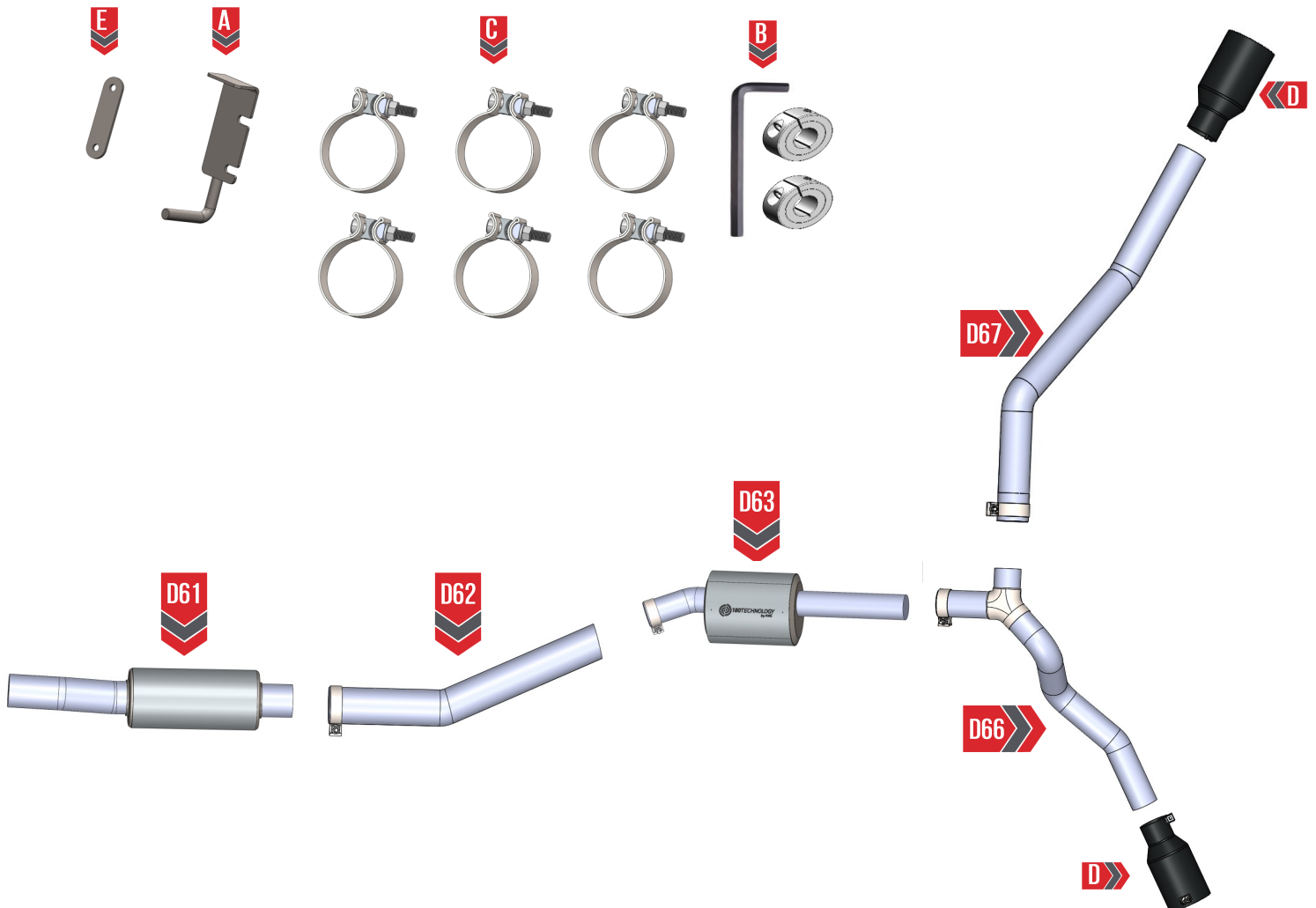

PARTS LIST (AWE TREAD EDITION CATBACK SINGLE-SIDE EXHAUST)



INSPECT ALL PARTS PRIOR TO DISASSEMBLY OF VEHICLE; IF DAMAGED OR MISSING, PLEASE CONTACT THE PLACE OF PURCHASE IMMEDIATELY.

Symbol	Part Number	Description	QTY
	D61	JT Jeep Gladiator 3.6L Flared Inlet 75/76MM with 3X6 Resonator	1
	D62	JT Jeep Gladiator 3.6L Mid Hanger Tube	1
	D63	JT Jeep Gladiator 3.6L HR5 Section	1
	D65	JT Jeep Gladiator 3.6L Single Outlet (Driver Side)	1
A >>	TAS300	3.00in Accu-Seal, Stainless Steel Band Clamp	4
B >>	180003BC	5" x 10" Straight cut Tip	1

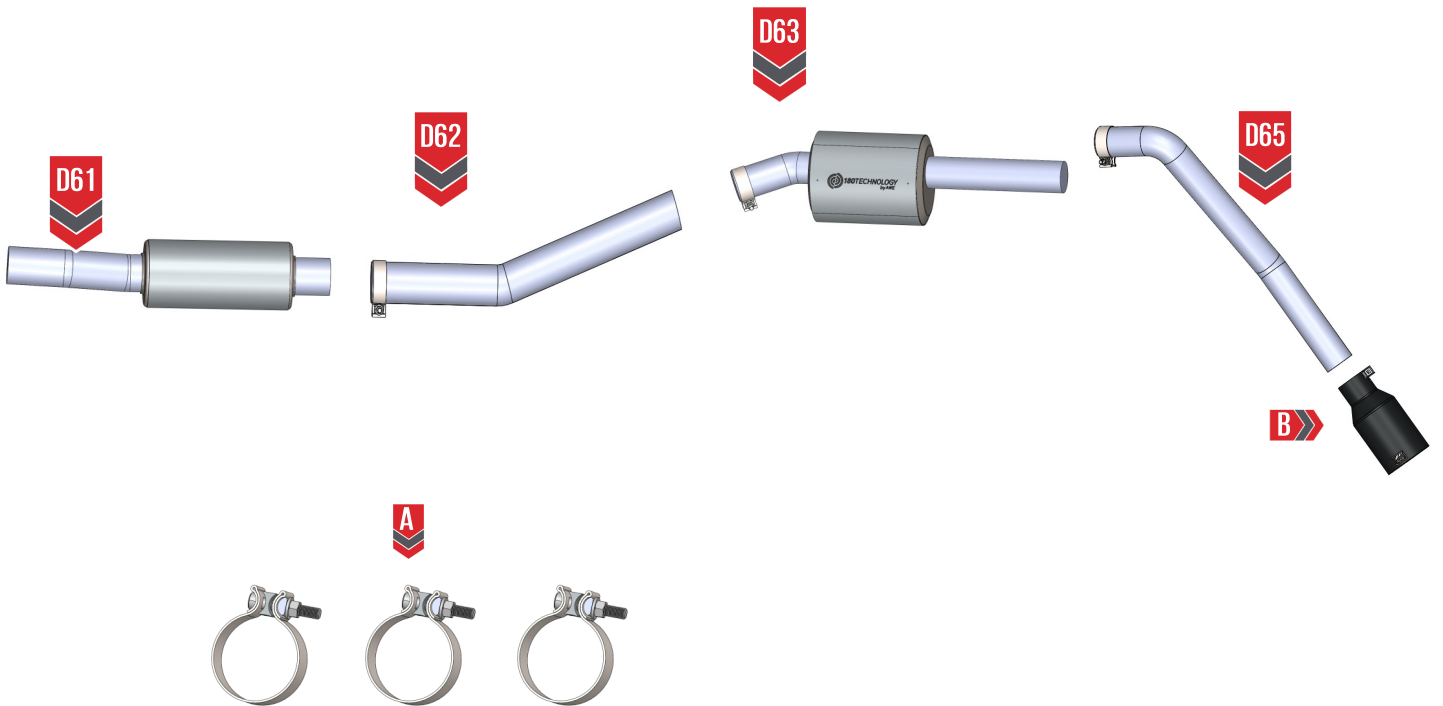

PARTS LIST (AWE TRAIL EDITION CATBACK EXHAUST)



INSPECT ALL PARTS PRIOR TO DISASSEMBLY OF VEHICLE; IF DAMAGED OR MISSING, PLEASE CONTACT THE PLACE OF PURCHASE IMMEDIATELY.

Symbol	Part Number	Description	QTY
	D61	JT Jeep Gladiator 3.6L Flared Inlet 75/76MM with 3X6 Resonator	1
	D62	JT Jeep Gladiator 3.6L Mid Hanger Tube	1
	D63	JT Jeep Gladiator 3.6L HR5 Section	1
	D64	JT Jeep Gladiator 3.6L Crawler Outlet	1
A	TAS300	3.00in Accu-Seal, Stainless Steel Band Clamp	3

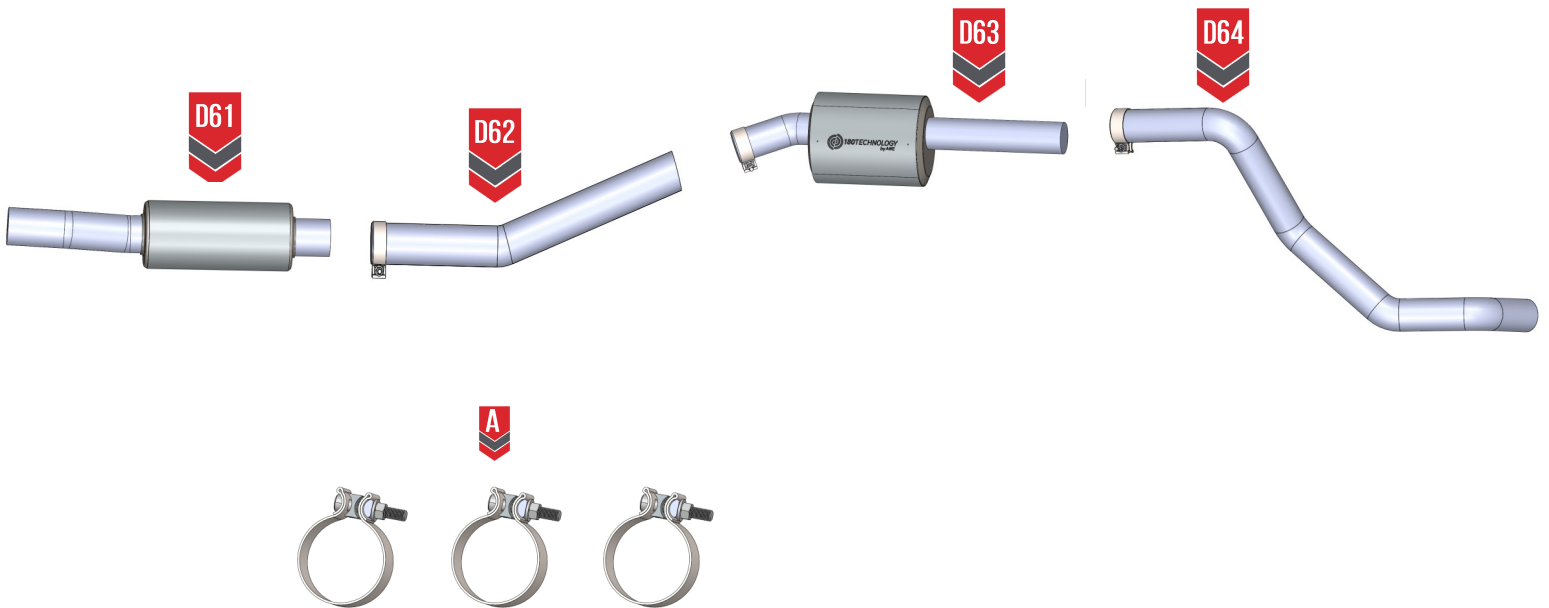



NOTE: Always refer to the manufacturer's service manual for precise torque specifications on all OEM fasteners.



CAUTION: The exhaust may be **VERY HOT** — allow adequate time for the system to cool down before disassembly. Severe burns and injury will occur if skin comes into contact with a hot exhaust system.

Table of Contents

OE Removal (Step 1)



AWE **Mid-Section** Install (Steps 2 - 4)

AWE **Dual** Exhaust Install (Steps 5 - 10)

AWE **Single** Exhaust Install (Steps 11 - 14)

AWE **Trail** Exhaust Install (Steps 15 - 18)

STEP 1

Uninstall OE JT exhaust by following these steps.

1. Remove the spare tire.
2. Remove heat shield around the spare tire.
3. Unbolt 2 bolts from rear hanger, save for later
4. Loosen the bolt on the ball socket. There is a small tab you will need to be bent to allow it to be removed.
5. Remove exhaust out rear/ over the axle.

STEP 2

Install the AWE front pipe with resonator (**D61**), use the OE ball clamp (**A**), at this point just snug the clamp to allow for alignment, as shown in **Figure 2**.



FIGURE 2

STEP 3

Install the AWE mid pipe with hanger (**D62**), using the OE hanger location (**A**) and a supplied clamp (**B**). At this time just snug the clamp, as shown in **Figure 3**.

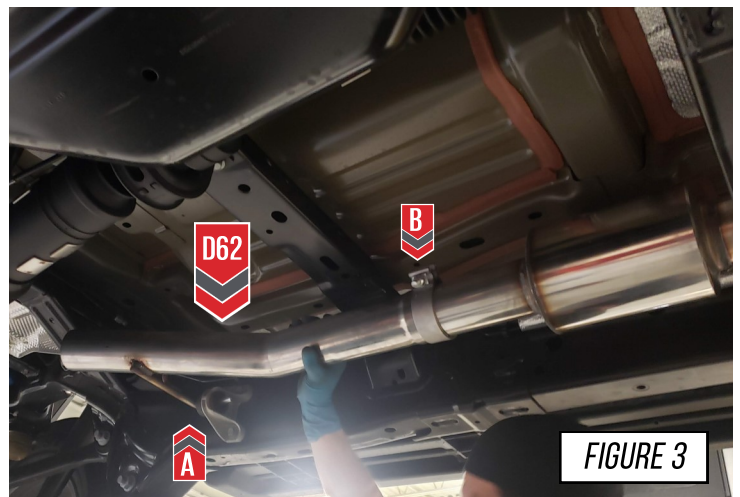

FIGURE 3

STEP 4

Install the AWE HR5 pipe (**D63**), use the OE hanger location (**A**), as shown in **Figure 4-1**. Use a supplied clamp (**B**), as shown in **Figure 4-2**.



FIGURE 4-1

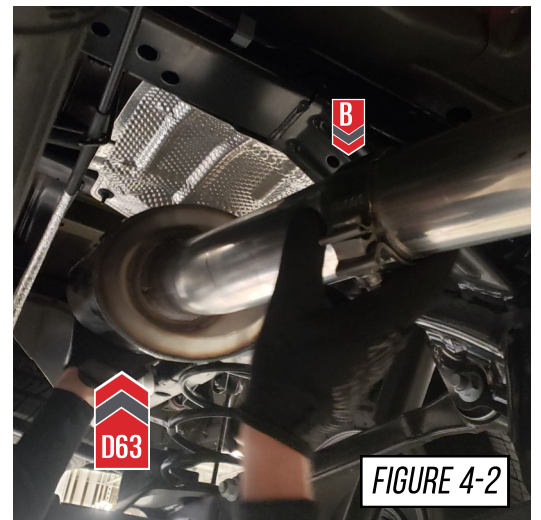

FIGURE 4-2

Table of Contents



AWE **Dual** Exhaust (Steps 5 - 10)

AWE **Single** Exhaust (Steps 11 - 14)

AWE **Trail** Exhaust (Steps 15 - 18)

STEP 5

Install the AWE Dual outlet pipe (**D66**), using the supplied clamp (**A**) and the OE hanger, at this point just snug the clamp, as shown in **Figure 5-1**. Install the OE bolts (**B**) and ensure there is a gap between the frame and hanger (**C**), shown in **Figure 5-2**.

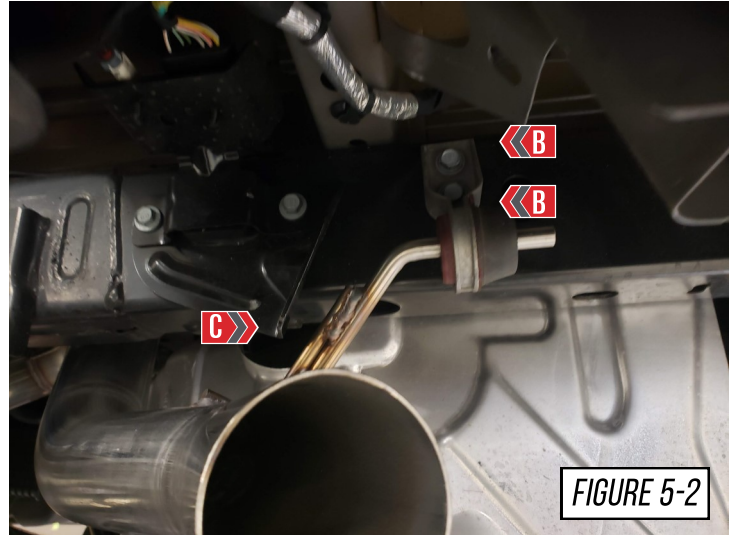
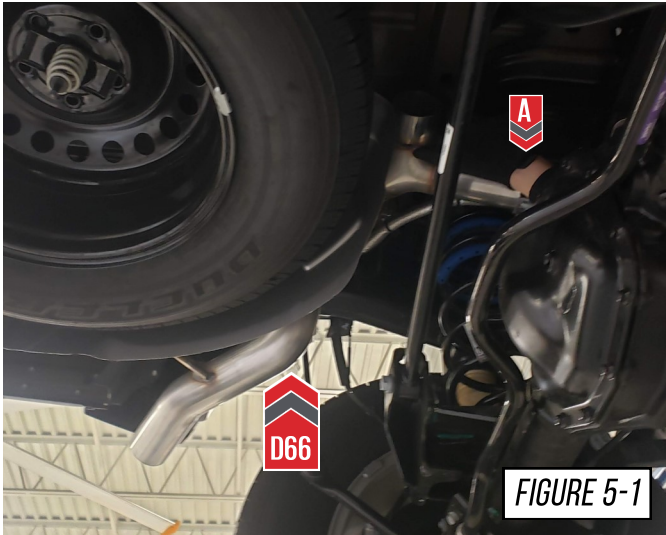

STEP 6

Install the AWE hanger kit on the passenger side of the truck. First insert the 2 bolt plate through the frame hole (**A**), and into place (**B**), as shown in **Figure 6-1**. Next install the hanger (**C**) and use the supplied nut and lock washer and tighten the hanger bolts. Install the supplied rubber hanger (**D**), as shown in **Figure 6-2**.



Keep the hanger bar straight up and down.

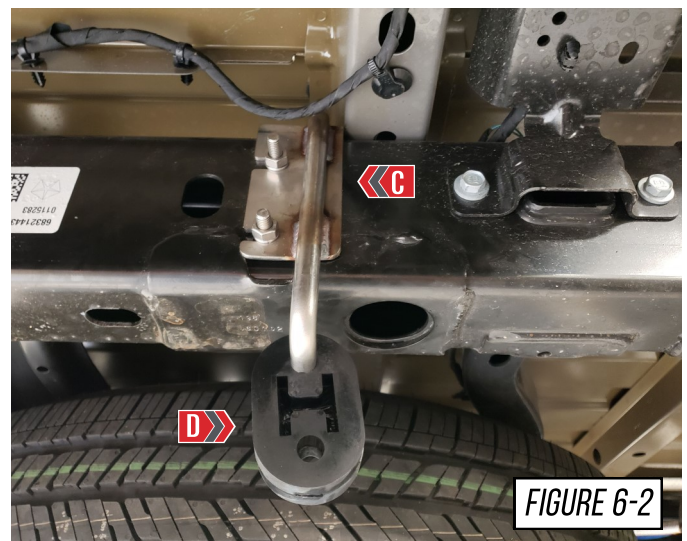
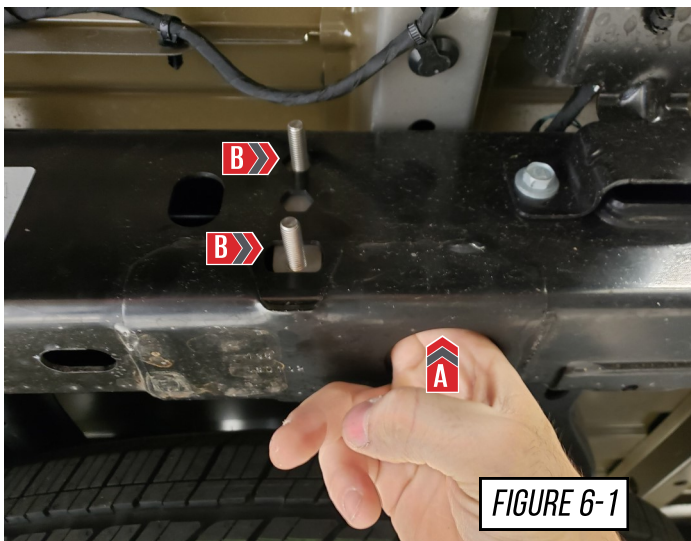

STEP 7

Install the AWE Dual outlet passenger side pipe (**D67**), use the supplied clamp (**A**), at this point just snug the clamp, and attach the hanger (**B**), shown in **Figure 7-1**. To help with tip alignment, make the pipe (**C**) parallel to edge of the shield (**D**), shown in **Figure 7-2**.

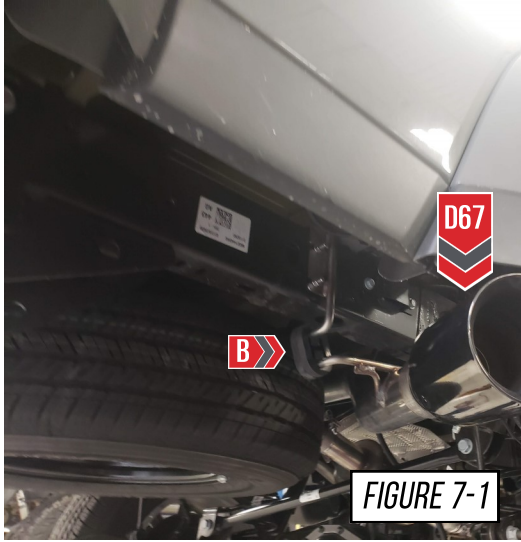

FIGURE 7-1

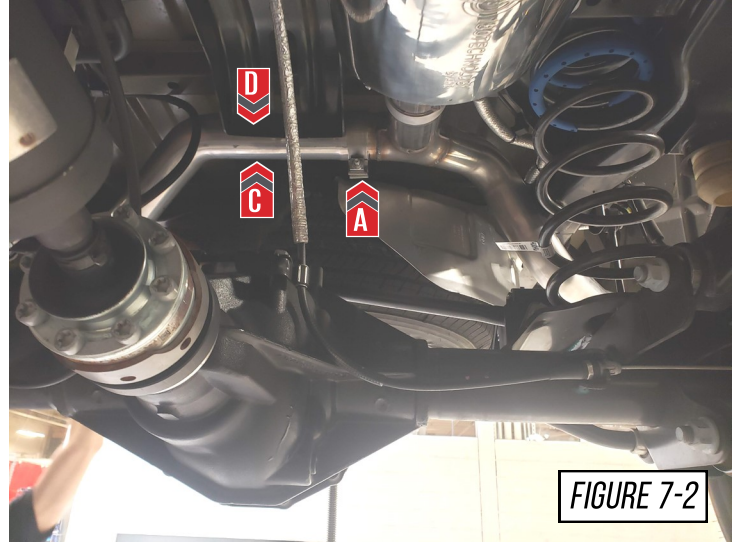

FIGURE 7-2

STEP 8

Install the AWE tips, use the supplied clamps, as shown in **Figure 8-1** and **8-2**.



FIGURE 8-1



FIGURE 8-2

STEP 9

It is crucial to install each section and exhaust band clamps correctly to prevent loose joints, exhaust leaks and rattles.

Arrow A shows the expanded pipe and the preinstalled exhaust clamp being brought up to the corresponding pipe.

Arrow B shows the overlapping pipe installed correctly over the corresponding pipe.

Arrow C shows the exhaust band clamp being brought to the edge of the expanded pipe.



NOTES:

- **Do not** fully torque any exhaust clamp until the entire exhaust has been installed and adjusted.
- Torque specification is a **minimum** of 60 ft/lbs

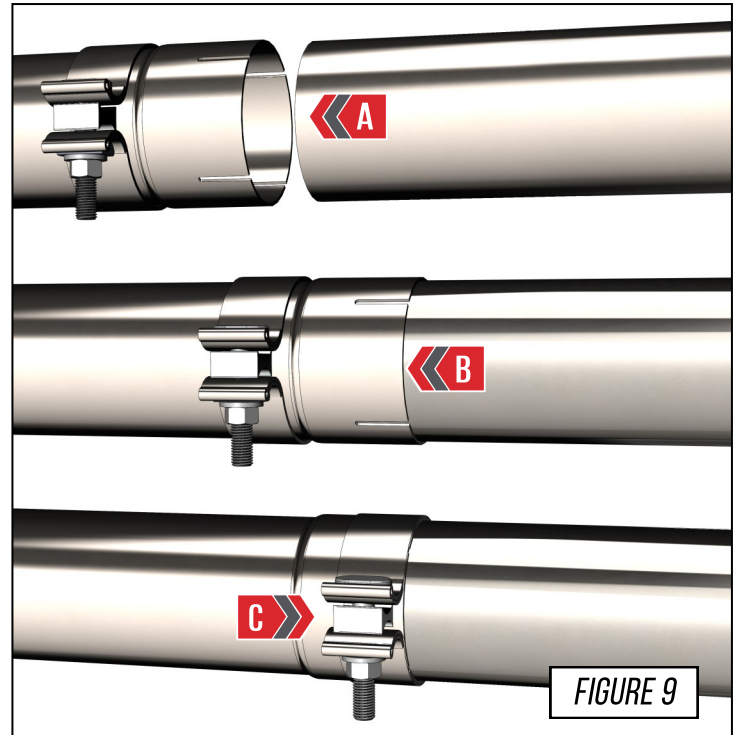

FIGURE 9

STEP 10

Create an even spacing around each tip, adjust the slip fits and rotate the ball socket (**A / B**), keeping the 2 pipe straight in line with each other, as shown in **Figure 10-1**. Reinstall the spare tire and heat shield (**C**), as shown in **Figure 10-2**.



As you achieve the desired fitment tighten the clamps to at least 60 ft/lbs.

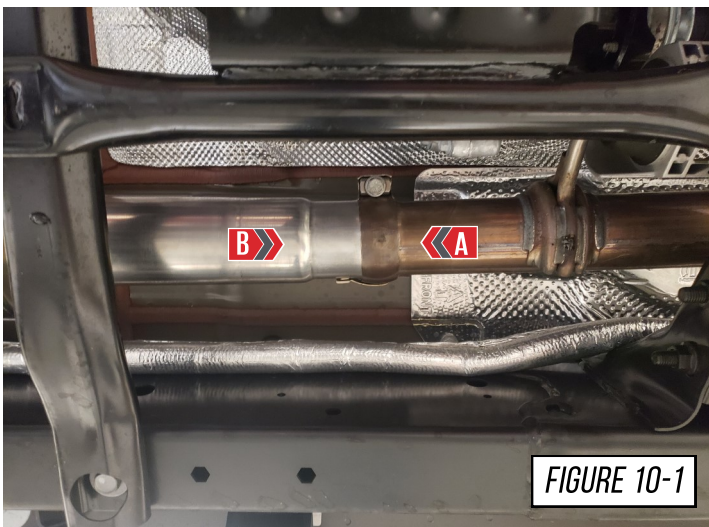

FIGURE 10-1



FIGURE 10-2

ENJOY!



Table of Contents



AWE **Dual** Exhaust (Steps 5 - 10)

AWE **Single** Exhaust (Steps 11 - 14)

AWE **Trail** Exhaust (Steps 15 - 18)

STEP 11

Install the AWE Single outlet pipe (**D65**), using the supplied clamp (**A**), as shown in **Figure 11**.

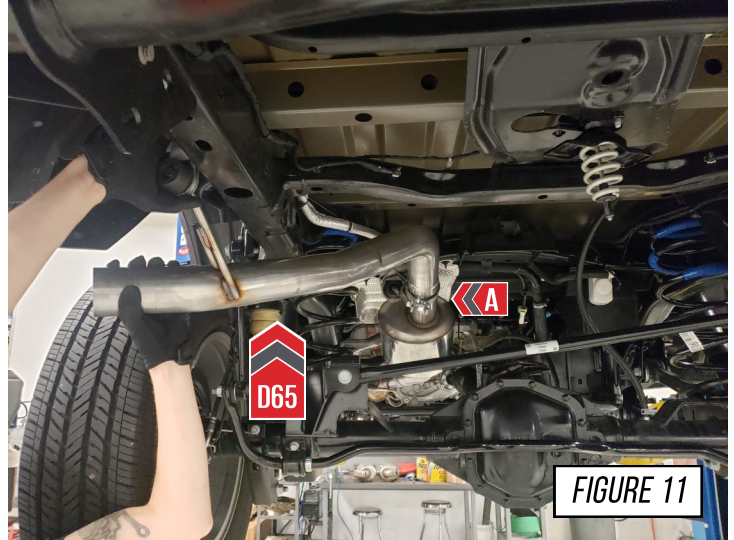

STEP 12

It is crucial to install each section and exhaust band clamps correctly to prevent loose joints, exhaust leaks and rattles.

Arrow A shows the expanded pipe and the preinstalled exhaust clamp being brought up to the corresponding pipe.

Arrow B shows the overlapping pipe installed correctly over the corresponding pipe.

Arrow C shows the exhaust band clamp being brought to the edge of the expanded pipe.



NOTES:

- **Do not** fully torque any exhaust clamp until the entire exhaust has been installed and adjusted.
- Torque specification is a **minimum** of 60 ft/lbs

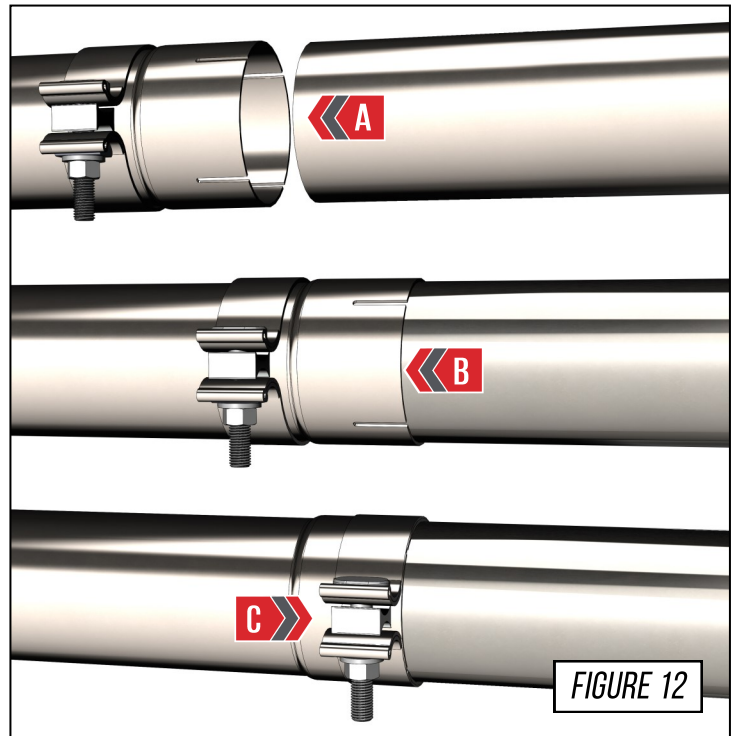

STEP 13

Reinstall the OE hanger using the OE hardware (A). Ensure there is a gap between the frame and the hanger (B), archive this by adjusting the slip fits, shown in **Figure 13**.

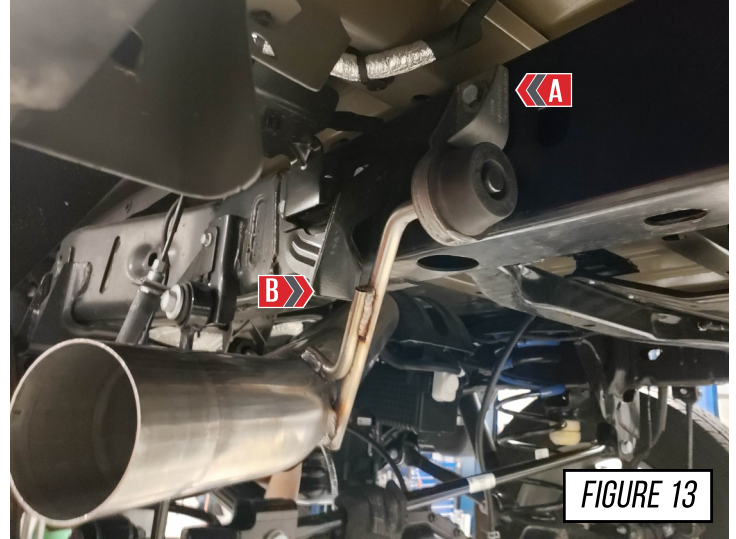

STEP 14

Install the AWE tips, use the supplied clamp. Check for proper clearance and tighten all clamps in the system to at least 60 ft/lbs. Reinstall the spare tire and heat shield, as shown in **Figure 14**.

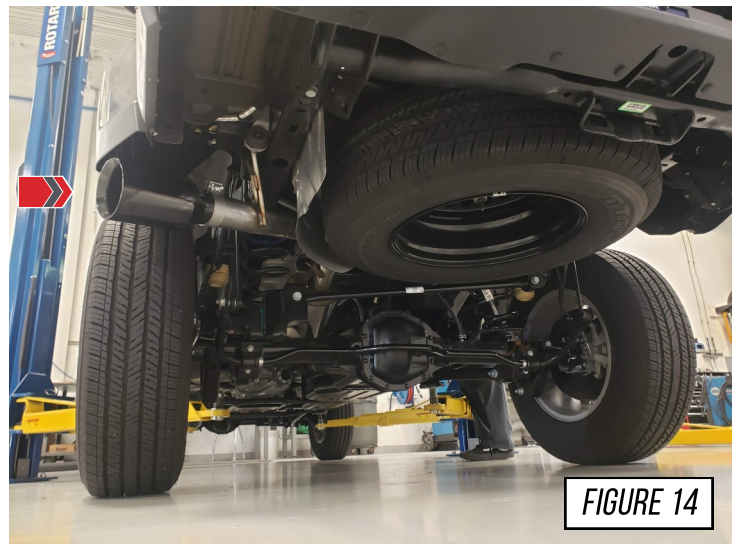

ENJOY!



Table of Contents



AWE **Dual** Exhaust (Steps 5 - 10)

AWE **Single** Exhaust (Steps 11 - 14)

AWE **Trail** Exhaust (Steps 15 - 18)

STEP 15

Install the AWE Trail outlet pipe (**D64**), using the supplied clamp (**A**), shown in **Figure 15-1** and **Figure 15-2**.



STEP 16

It is crucial to install each section and exhaust band clamps correctly to prevent loose joints, exhaust leaks and rattles.

Arrow A shows the expanded pipe and the preinstalled exhaust clamp being brought up to the corresponding pipe.

Arrow B shows the overlapping pipe installed correctly over the corresponding pipe.

Arrow C shows the exhaust band clamp being brought to the edge of the expanded pipe.



NOTES:

- **Do not** fully torque any exhaust clamp until the entire exhaust has been installed and adjusted.
- Torque specification is a **minimum** of 60 ft/lbs

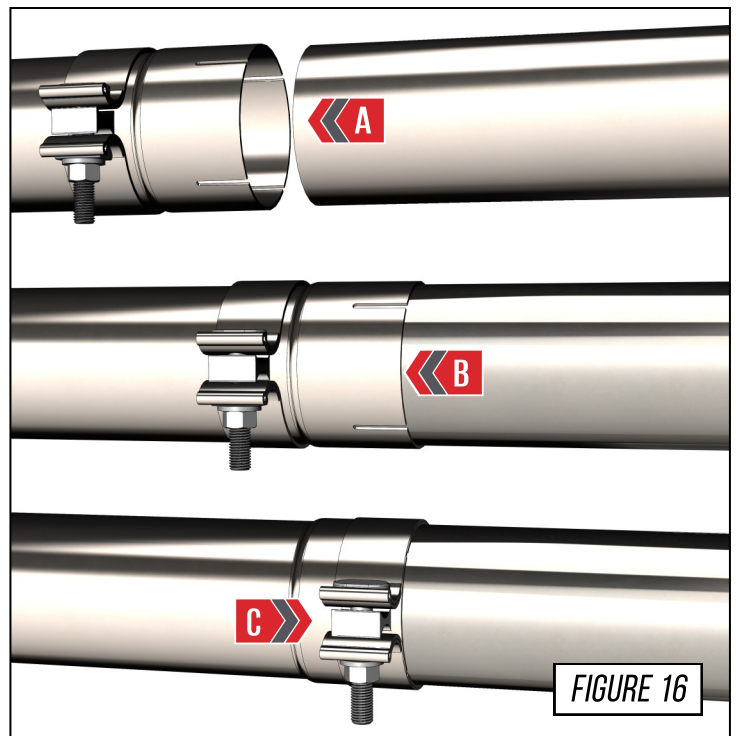

STEP 17

Reinstall the OE hanger using the OE hardware (**A**). Ensure there is a gap between the frame and the hanger (**B**), archive this by adjusting the slip fits, shown in **Figure 17**.

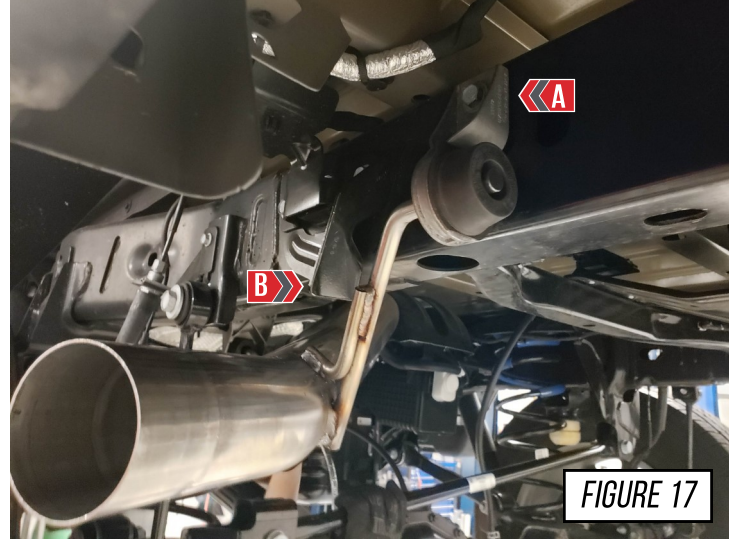

STEP 18

Check for proper clearance and tighten all clamps in the system to at least 60 ft/lbs. Reinstall the spare tire and heat shield, as shown in **Figure 18**.

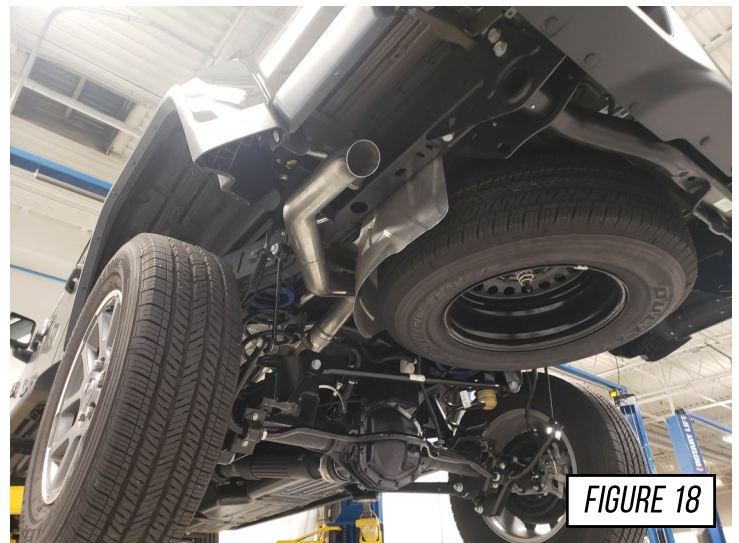

ENJOY!



TROUBLESHOOTING

Issue	Solution
Exhaust is not fitting correctly	Most fitment issues are due to improperly adjusted exhaust. This includes tip fitments and rattling due to chassis contact. Check out our fitment guide for more installation tips.
Wrong or missing parts	Double check the parts list for your system and compare them with what you received. Fill out our contact form, found below and let us know what parts you need.

CARE

Once installed properly, your AWE exhaust will provide years of trouble-free performance.

The exhaust volume and sound will settle with usage; 800-1000 miles is required to break-in new exhaust systems.

Also, please note that the rear **180Technology®** resonator has a small drain hole to allow condensation to escape. Water drops from this area are normal.

Periodic cleaning of exhaust tips is necessary to maintain proper finish, especially in areas prone to road salt and caustic deicing solutions. Use a mild soap and water solution or car wax to clean the finish. Avoid using abrasive polishes, as they can scratch the finish.