

**HEAVY DUTY REAR BUMPER  
2010-18 RAM 25-3500**

**PARTS LIST:**

1	Heavy Duty Rear Bumper Assembly	10	12mm Nylon Lock Nuts
1	Universal License Plate Light	4	8mm x 40mm Hex Bolts
4	15.5mm x 25mm x 2mm Foam Sensor Seals	4	8mm x 28mm x 3mm Flat Washers
4	Sensor Retaining Clips	4	8mm Lock Washers
4	Sensor Hole Plugs	10	4mm x 10mm Button Head Screws
1	Sensor Covers Kit	4	4mm x 12mm x 1mm Flat Washers
2	Wire Harnesses	2	4mm Lock Washers
2	License Plate Plugs	2	4mm Hex Nuts
10	12-1.75mm x 50mm Hex Bolts	1	Allen Wrench
20	12mm x 37mm x 3mm Flat Washers		

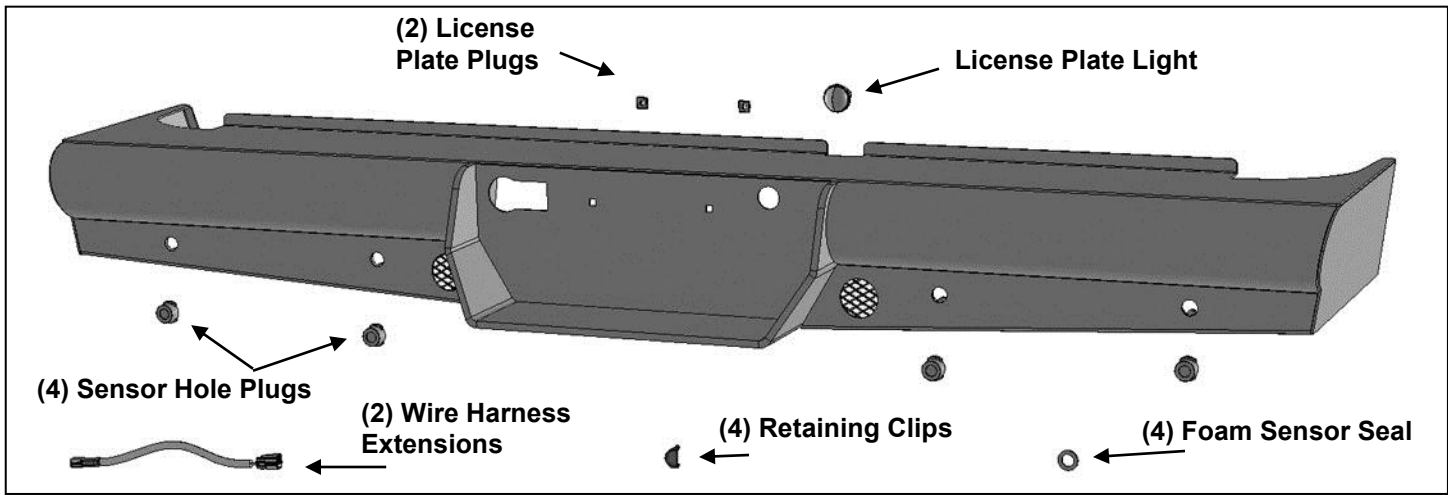

**PROCEDURE:**

**REMOVE CONTENTS FROM BOX. VERIFY ALL PARTS ARE PRESENT. READ INSTRUCTIONS CAREFULLY BEFORE STARTING INSTALLATION. BUMPER IS HEAVY, ASSISTANCE IS HIGHLY RECOMMENDED TO AVOID POSSIBLE INJURY OR DAMAGE TO THE VEHICLE.**

1. Remove the license plate. Unplug all wiring harnesses leading to the rear bumper and move harnesses away from frame and bumper, **(Figure 1)**.
2. Place blocks or jack stands under the bumper to support it during bumper bolt removal. Once the bumper has been safely supported, with assistance, remove the factory bumper bolts and slide the rear bumper off of the end of the frame, **(Figures 2—4)**. **WARNING!** Assistance is required to hold the bumper in place during hardware removal to prevent the bumper from falling.
3. Unplug the factory license plate lights and remove the wiring harness from the bumper. Next, remove the trailer plug from the bumper if equipped, **(Figure 1)**.
4. Determine if vehicle is equipped with parking and/or tire pressure monitoring sensors. **NOTE:** It may be easier to attach sensors to Bumper before installing Bumper Assembly.

**Models without bumper sensors:**

- a. Select the included (4) Rubber Plugs.
- b. From behind bumper, push plugs into sensor mounting holes, **(Figure 5)**.

**Models with bumper mounted parking sensors:**

- a. Remove sensors from factory bumper, **(Figure 6)**. Remove the plastic sleeves from the sensors, **(Figure 7)**.
- b. Remove factory front seal from sensor. Attach larger Foam Seal onto the front of the sensor, **(Figure 8)**.
- c. Push the sensor in from the back of the Bumper until it is flush with the sensor mounting sleeve. Push (1) Retaining Clip into sensor sleeve to secure the sensor in place, **(Figure 8)**.
- d. Repeat the previous steps for the remaining parking sensors.
- e. Starting on the driver side, run the OE sensor wire harness through the bumper cutouts. Connect the first two driver side sensors to the OE sensor wire harness.

**HEAVY DUTY REAR BUMPER  
2010-18 RAM 25-3500**

- f. Use the provided wire harness extensions to connect the remaining two passenger side sensors to the OE sensor wire harness.
- g. Plug harness into parking sensors.

**Models with TPMS (tire pressure monitoring system).**

- a. Remove the sensor from the back of the bumper, **(Figure 9)**. **NOTE:** It may be necessary to partially disassemble the plastic bumper panel to remove the sensor.
  - b. Attach the sensor to tabs on back of bumper with included (2) 4mm Button Head Screws, (4) 4mm Flat Washers, (2) 4mm Lock Washers and (2) 4mm Hex Nuts, **(Figures 10 & 11)**. Do Not Overtighten 4mm hardware or damage to sensor could result.
  - c. Once installed, plug wiring harness into TPMS sensor.
5. Locate the mounting slots behind the Bumper for accessory light installation if desired, **(Figure 8)**.  
**NOTE:** Lights not included.
6. With assistance, position the HD Bumper Assembly up and over the bumper brackets on the ends of the frame and factory tow hitch, **(Figure 12)**. Temporarily support the Bumper Assembly. **WARNING:** To avoid possible injury or damage to the vehicle, do not proceed until the Bumper is fully and safely supported.
7. Line up the (2) outer holes in the passenger side frame mounting bracket with the (2) holes in the mounting plate on the back of the Bumper. Attach the Bumper to the frame bracket with (2) 12mm Hex Bolts, (4) 12mm Flat Washers and (2) 12mm Nylon Lock Nuts, **(Figure 12)**. Leave hardware loose at this time. Repeat this Step to attach the driver/left side of the Bumper to the bracket.
8. Next, line up the (2) inner holes on the frame bracket with the mounting plate on Bumper. Select the correct installation. **NOTE:** On some models/years, the frame bracket may only be equipped with outer mounting holes. Adjust installation accordingly, **(Figures 2 & 12)**.

**Models with 8mm hex nuts welded onto the back of the frame bracket:**

- a. Use the included (2) 8mm Hex Bolts, (2) 8mm Lock Washers and (2) 8mm Flat Washers to attach the passenger/right side of the Bumper to the frame bracket, **(Figures 2 & 12)**. Repeat this Step to attach the driver/left side of the bumper to the frame bracket. Leave hardware loose.

**Models with open mounting holes in frame bracket:**

- a. Use (2) 12mm Hex Bolts, (4) 12mm Flat Washers and (2) 12mm Nylon Lock Nuts to attach the passenger side of the HD Bumper to the frame bracket, **(Figure 12)**. Repeat this Step to attach the driver side of the HD Bumper to the frame bracket. Leave hardware loose at this time.
9. Line up the (2) holes in the center mounting plate on the back of the Bumper with the (2) holes in the top of the tow hitch. Attach the Bumper to the tow hitch with (2) 12mm Hex Bolts, (4) 12mm Flat Washers and (2) 12mm Nylon Lock Nuts, **(Figure 13)**. Leave hardware loose at this time.
10. Level and adjust the Bumper and fully tighten all hardware.
11. Snap the plug for the trailer harness into the opening in the Bumper. Plug the wiring harness into the back of the plug.
12. Select the included License Plate Light. Insert the Light into the mounting hole in the bumper, **(Figure 14)**. Connect the wire harness to the License Plate Light. Tie down all wiring harnesses and seal off any open wiring connection.
13. Insert Plastic Plugs into square mounting holes for license plate, **(Figure 14)**.
14. Do periodic inspections to the installation to make sure that all hardware is secure and tight.

**To protect your investment**, do not use any type of polish or wax that may contain abrasives that could damage the finish. Mild soap may be used to clean the Heavy Duty Bumper assembly.

Passenger/right side installation pictured

**WARNING!** Do not remove bumper bolts unless the bumper is properly supported on blocks or stands or the bumper may fall.

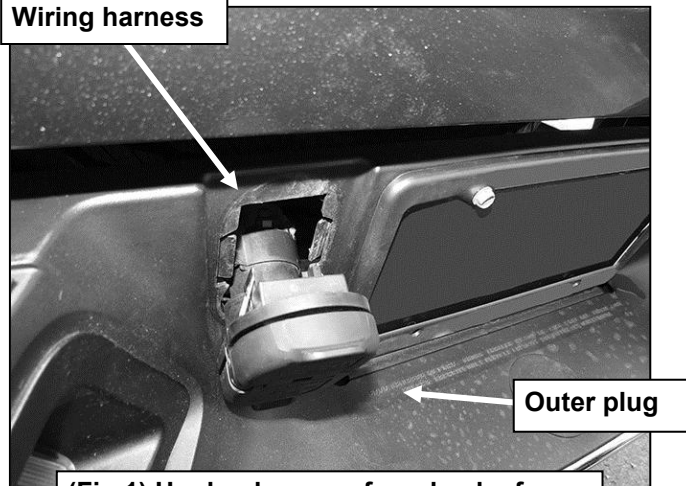

(Fig 1) Unplug harness from back of trailer connector then remove outer plug

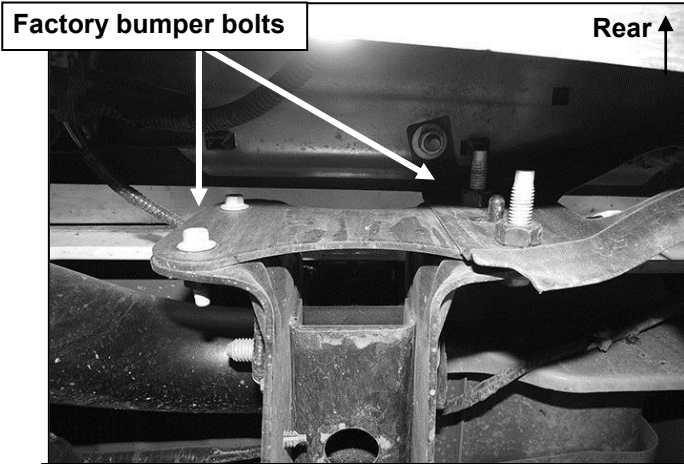

(Fig 2) Example of factory bumper bracket with 8mm hex nuts (left) welded onto back of bracket

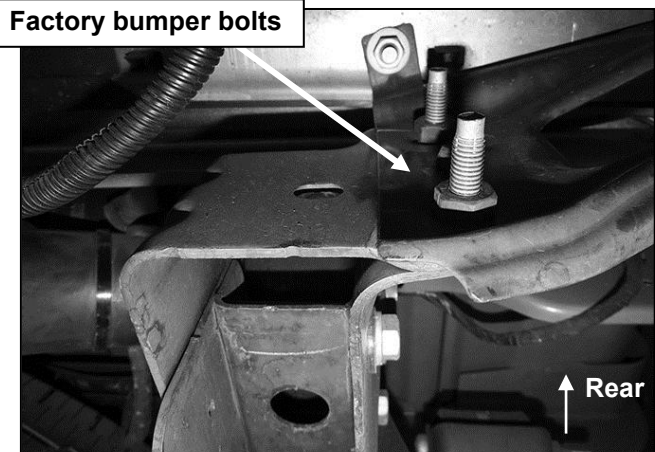

(Fig 3) Example of factory bumper bracket with (2) hex bolts only (right) pictured from below bumper

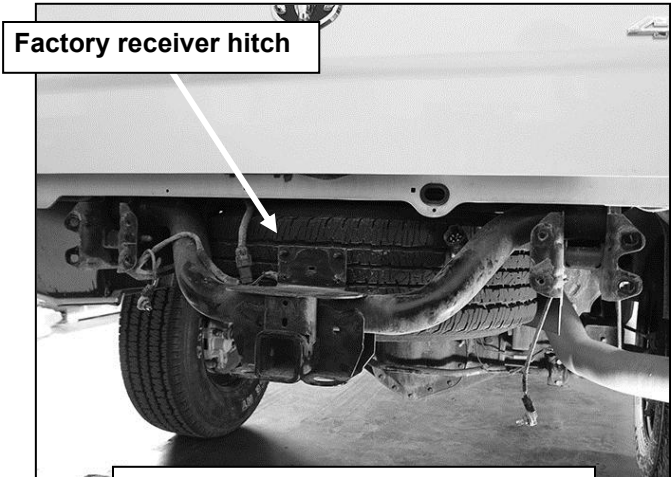

(Fig 4) Bumper completely removed

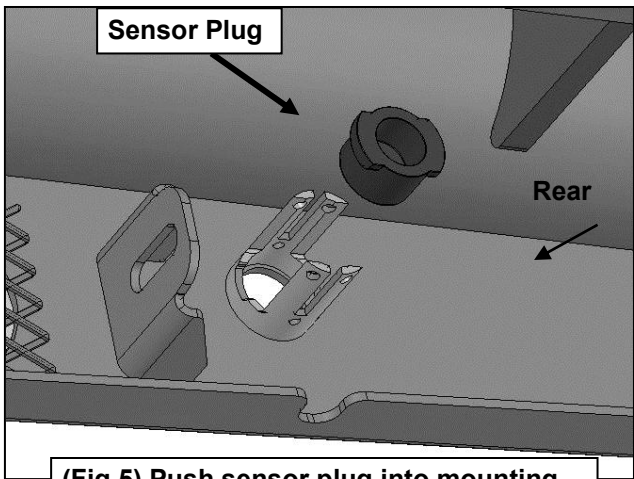

(Fig 5) Push sensor plug into mounting sleeve. Use of 4mm Screws is optional

Passenger/right side installation pictured

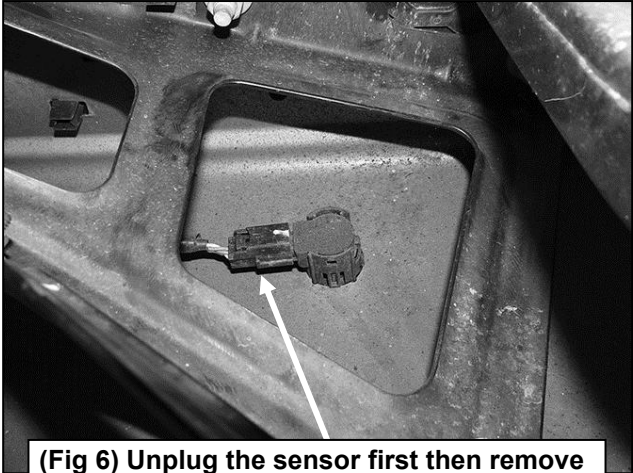

(Fig 6) Unplug the sensor first then remove the sensor from the mounting sleeve



(Fig 7) Remove the mounting sleeve (right) from each sensor

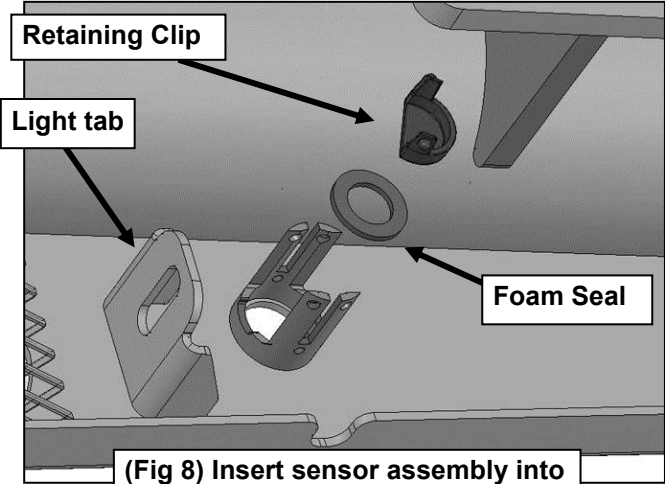

(Fig 8) Insert sensor assembly into sensor sleeve on back of bumper

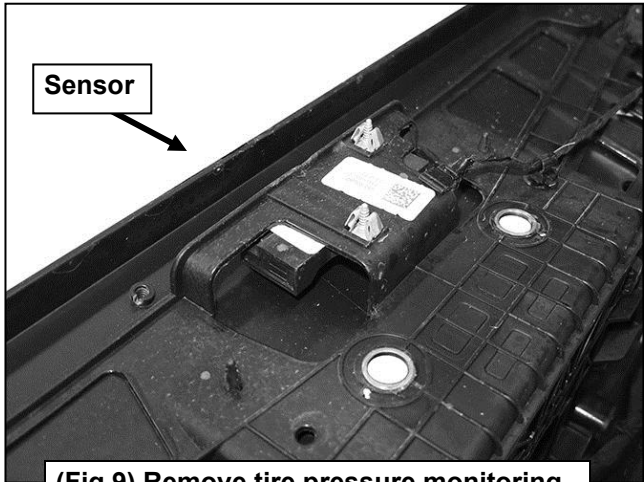

(Fig 9) Remove tire pressure monitoring sensor from back of bumper, if equipped



(Fig 10) Tire pressure monitoring sensor (TPMS)

**WARNING!** Do not crawl under bumper unless the bumper is properly supported on blocks or stands or the bumper may fall.

**HEAVY DUTY REAR BUMPER  
2010-18 RAM 25-3500**

**Passenger/right side installation pictured**

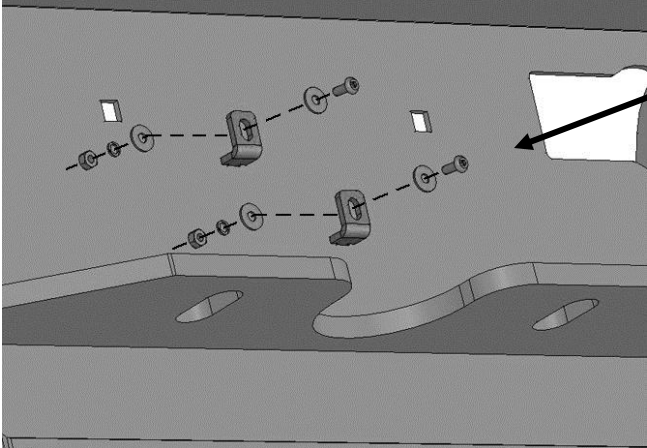

- (2) 4mm Screws
- (4) 4mm Flat Washers
- (2) 4mm Lock Washers
- (2) 4mm Hex Nuts

- On inner side of bracket, use:
- (2) 12mm Hex Bolts
  - (4) 12mm Flat Washers
  - (2) 12mm Nylon Lock Nuts
- or
- (2) 8mm Hex Bolts
  - (2) 8mm Lock Washers
  - (2) 8mm Flat Washers

- (2) 12mm Hex Bolts
- (4) 12mm Flat Washers
- (2) 12mm Nylon Lock Nuts

**(Fig 11) Attach TPMS sensor to back of HD Bumper**

- (2) 12mm Hex Bolts
- (4) 12mm Flat Washers
- (2) 12mm Nylon Lock Nuts

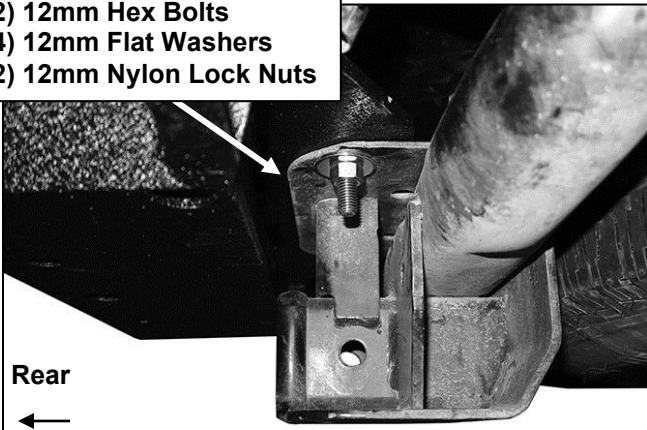

Rear  
←

**(Fig 13) Attach center plate on Bumper to top of factory hitch (pictured from below)**



Rear  
↑

**(Fig 12) Passenger side pictured from below**

**WARNING!** Do not crawl under bumper unless the bumper is properly supported on blocks or stands or the bumper may fall.



**Complete Installation**

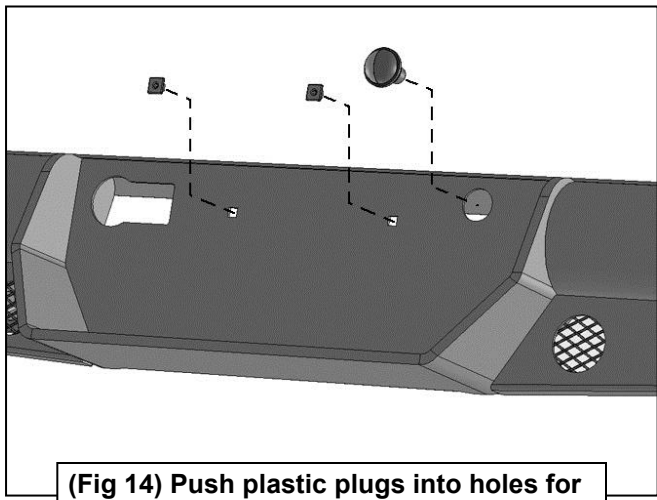

**(Fig 14) Push plastic plugs into holes for license plate. Insert License Plate Light**