

INSTALLATION INSTRUCTIONS

CUSTOMER SERVICE

Phone: 818-365-9000 • MON - FRI 8:30 am - 6:00 pm EST

Email: SUPPORT@BAKINDUSTRIES.COM

Any damaged or missing parts?

Parts will be shipped to you directly.

Call 818-365-9000 Mon-Fri 8:30am-7pm EST

or email support@bakindustries.com



IMPORTANT: READ FIRST

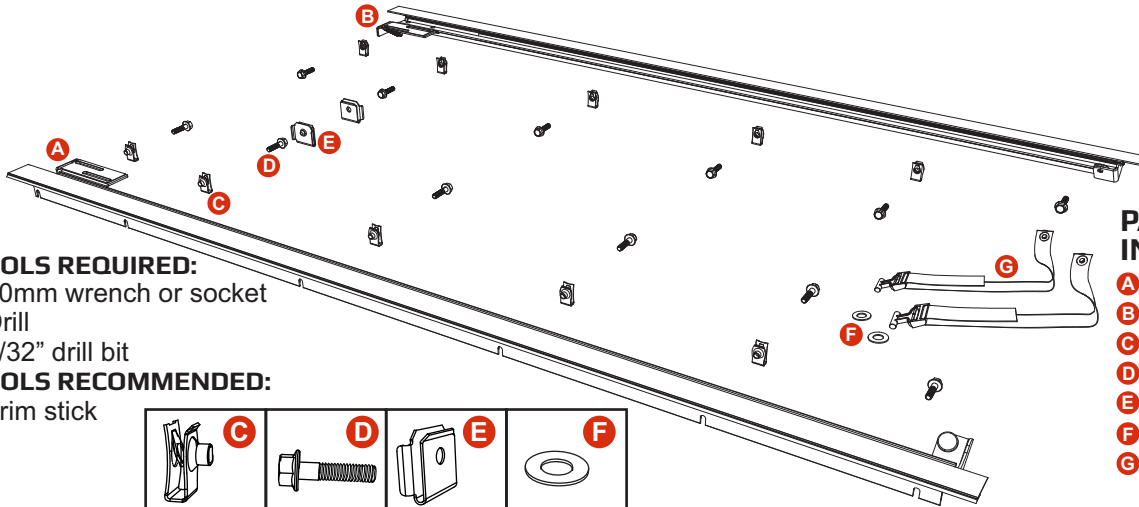

TOOLS REQUIRED:

- 10mm wrench or socket
- Drill
- 9/32" drill bit

TOOLS RECOMMENDED:

- Trim stick

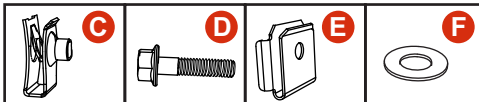

PARTS INCLUDED IN YOUR KIT

- A** 1 Driver side cover rail
- B** 1 Passenger side cover rail
- C** 10 Unuts
- D** 12 M6 Bolts
- E** 2 Hole guides
- F** 2 Washers
- G** 2 Straps

1 U-nut installation

Insert the U-nuts (C) by prying the plastic truck bed cap away from the truck bed. The U-nuts fit underneath the plastic truck bed cap and onto the carbon side (fig. 1). Make sure that the U-nut is aligned with the bed rail hole as shown in fig. 2. Repeat for the passenger side.

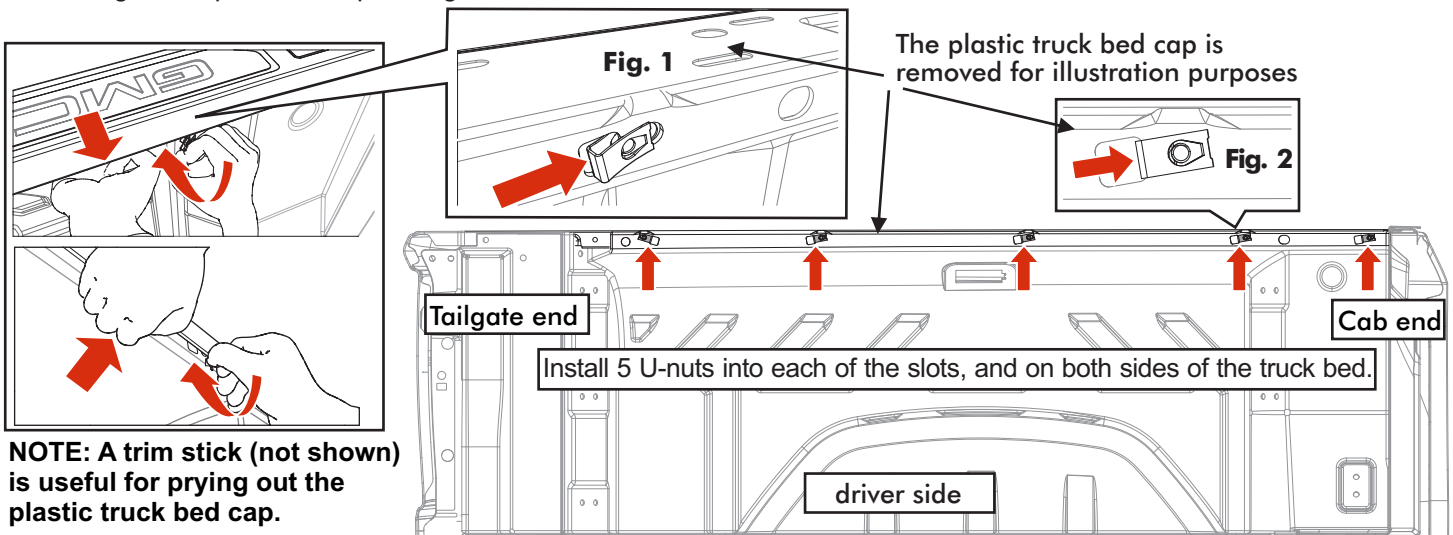

NOTE: A trim stick (not shown) is useful for prying out the plastic truck bed cap.

2 Drill mounting holes

Slide the bed cap hole guide (E) onto the edge of the plastic truck bed cap and in between the cap and the bed (fig. 3). Align the guide so that its back fits into the hole of the U-nut (fig. 4). Drill a 7mm, (9/32") hole through the plastic truck bed cap using the bed cap hole guide (fig. 5). The back of the guide will prevent the drill from hitting the truck bed. Repeat this for every U-nut location on both sides of the truck bed.

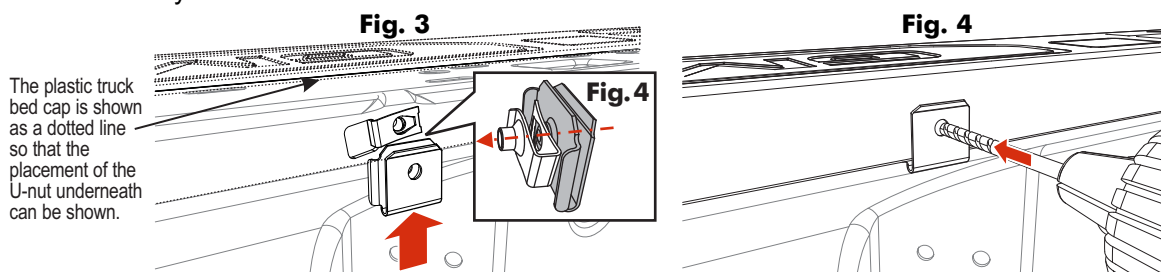

3 Drill mounting holes, continued

The truck bed cap sheet metal already has a threaded hole included (fig. 5). A hole must be drilled through the truck's plastic bed cap to access the threaded hole for mounting. Slide the hole drill guide (F) onto the edge of the truck's plastic bed cap and in between the cap and the bed. Align the hole drill guide so that the back of the hole guide aligns with the threaded hole. Drill a 7mm, (9/32") hole through the truck plastic bed cap using the hole drill guide. Repeat this on both sides of the truck bed.

The plastic truck bed cap is shown as a dotted line so that the placement of the threaded hole underneath can be shown.

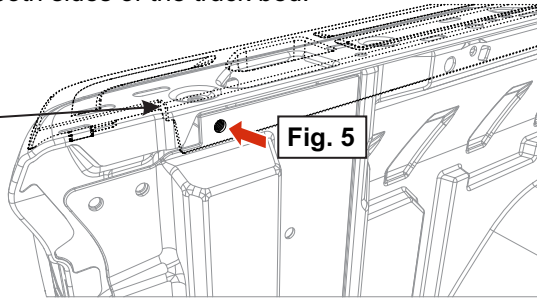

Tail end, driver side

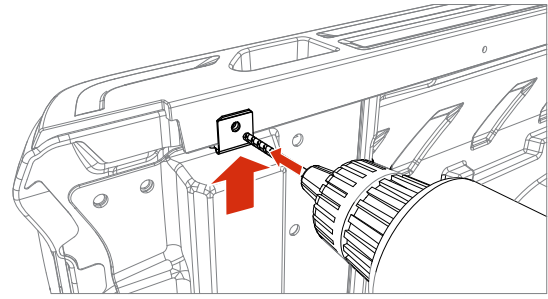

Tail end, driver side

4 Install the bolts and straps

Thread the M6 bolts (D) through the drilled holes and into the threaded hole (1), and the U-nuts (2,3,4,6) until they are spaced approximately 3.18mm (1/8") from the bed cap (fig. 6). The threaded hole and U-nut (5) will have the strap and washer installed with the bolt. Thread the M6 bolt through the washer, through the strap and into hole number 5 (fig. 7). Note that there needs to be the same spacing 3.18mm (1/8") between the strap and the bed cap (fig. 8)

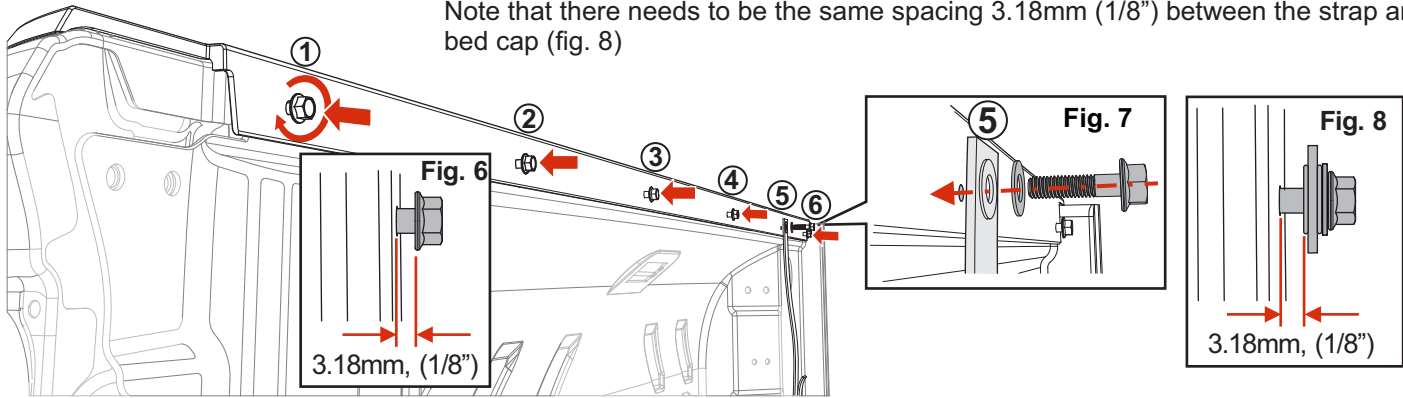

5 Place the cover rail

Place the driver side cover rail (A) by aligning the slots onto each of the bolts (fig. 9). Note that the cover rail is positioned between the truck bed cap and the strap (fig. 10). Push the cover rail down where it sits tightly on top of the truck bed cap. Push down on the cover rail and tighten the bolts with the 10mm open end wrench. Repeat the steps for the passenger side cover rail (B).

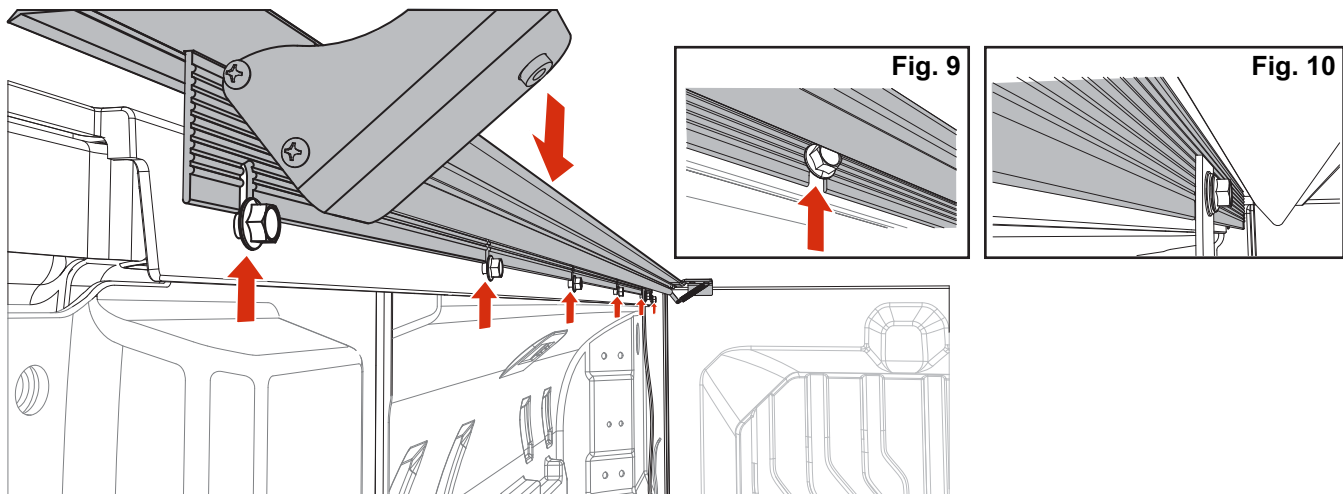

Return to the standard install instructions at step 6.

INSTALLATION INSTRUCTIONS

CUSTOMER SERVICE

Phone: 818-365-9000 • MON - FRI 8:30 am - 6:00 pm EST

Email: SUPPORT@BAKINDUSTRIES.COM

REVOLVERX2

HARD ROLLING COVER

REVOLVERX4s

PREMIUM MATTE HARD ROLLING COVER

INSTALLATION SHEET

Any damaged or missing parts?

Parts will be shipped to you directly.

Call 818-365-9000 Mon - Fri 8:30 am - 7 pm EST
or email support@bakindustries.com

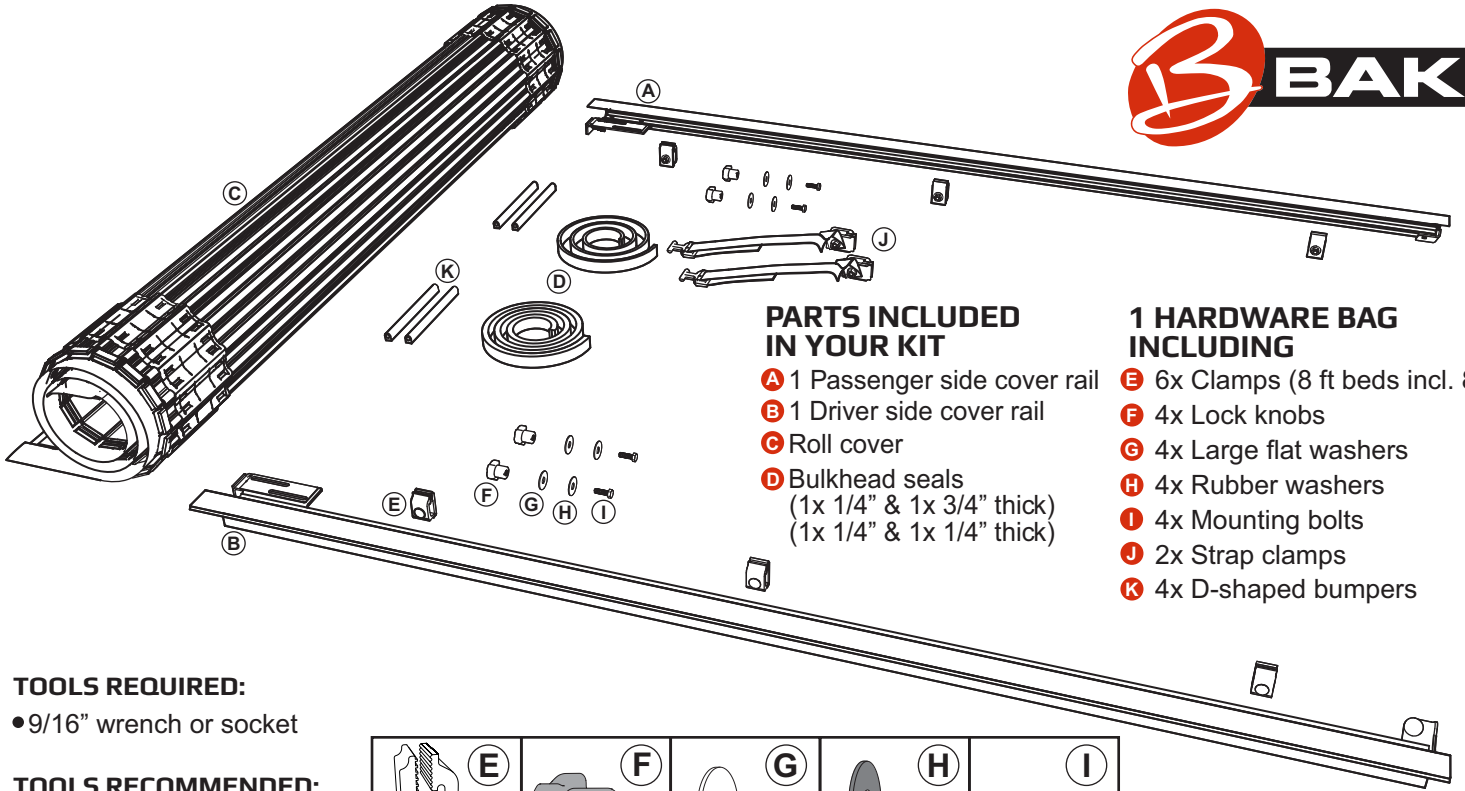

PARTS INCLUDED IN YOUR KIT

- A** 1 Passenger side cover rail
- B** 1 Driver side cover rail
- C** Roll cover
- D** Bulkhead seals (1x 1/4" & 1x 3/4" thick) (1x 1/4" & 1x 1/4" thick)

1 HARDWARE BAG INCLUDING

- E** 6x Clamps (8 ft beds incl. 8)
- F** 4x Lock knobs
- G** 4x Large flat washers
- H** 4x Rubber washers
- I** 4x Mounting bolts
- J** 2x Strap clamps
- K** 4x D-shaped bumpers

TOOLS REQUIRED:

- 9/16" wrench or socket

TOOLS RECOMMENDED:

- Torque wrench
- Blow dryer or heat gun

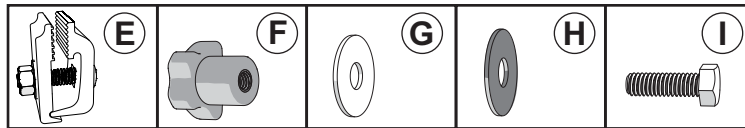

1 Clean the top of the bulkhead to install the bulkhead seal (D). Peel the backing and adhere the seal at the edge of the bed opening. If the truck **does NOT** have a drop-in bedliner, use the 3/4" seal. If the truck **does** have a drop-in bedliner, use the 1/4" seal.

2 Position the passenger side cover rail (A) on the truck rail with the slotted bracket pushed all the way toward the front/cab and the bulkhead. If the truck is equipped with a drop-in bedliner, remove the foam pads located at the front of the slotted brackets.

NOTE: Some drop-in bedliners may require trimming in the corners to fit the rail into the opening.

3 Position the first clamp (E) as close to the front end of the cover rail as possible, 12" or less from the end. Make sure the cover rail is clamped square and level. Hand tighten to 10 ft/lbs of torque with a 9/16" wrench or socket. Apply downward pressure to the cover rail when tightening the clamps to ensure that the rail sits flush and the seals are set.

NOTE: When installing each clamp, make sure that the clamps are inserted as far up onto the rail as possible and that the clamp teeth fit squarely and fully engage the ribs of the cover rail.

CAUTION: over tightening the clamps could cause warping of the bed cap.

4

Place the second clamp (E) near the center of the cover rail.
For 8' beds two clamps will be evenly spaced in the center section of the cover rail.
Hand tighten to 10 ft/lbs of torque with a 9/16" wrench or socket.

Always apply downward pressure to the cover rail when tightening the clamps to ensure that the rail sits flush and the seals are set.

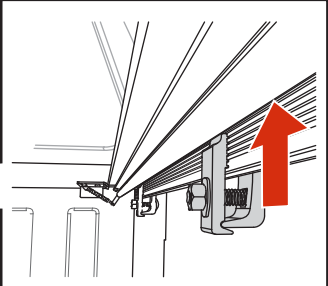
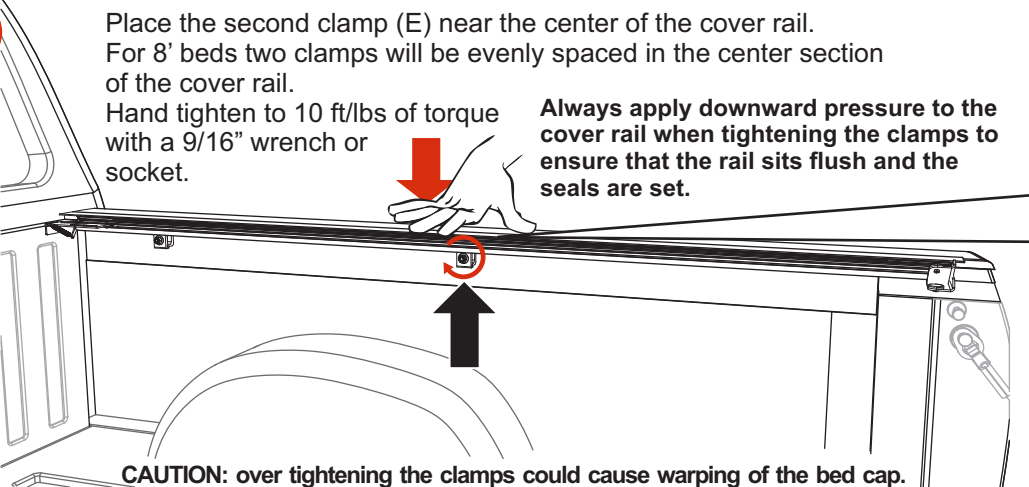

Always make sure that the clamps are inserted as far up onto the cover rail as possible and that the clamp teeth fit squarely and fully engage the ribs of the cover rail.

CAUTION: over tightening the clamps could cause warping of the bed cap.

5

Place the rear clamp (E) as close to the tailgate as possible, it should be less than 12" from the tailgate. Check that all of the clamps are square and hand tighten to 10 ft/lbs of torque with a 9/16" wrench or socket.

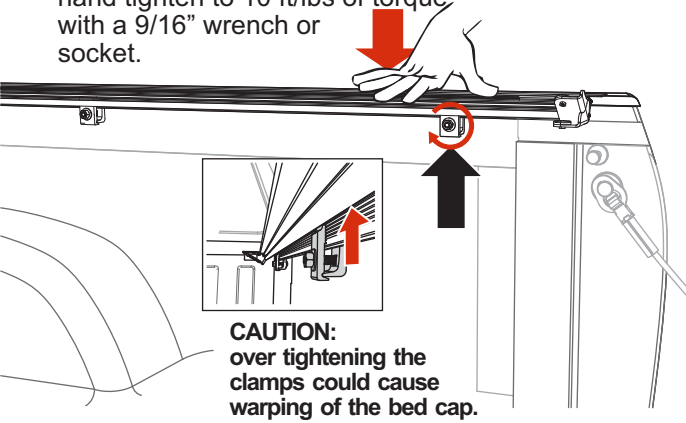

CAUTION: over tightening the clamps could cause warping of the bed cap.

Repeat steps 2 through 5 for the driver side rail.

6

With both rails clamped in place, rest the rolled cover (C) onto the rails at the tailgate, roll the cover toward the cab, remove and discard all packaging materials.

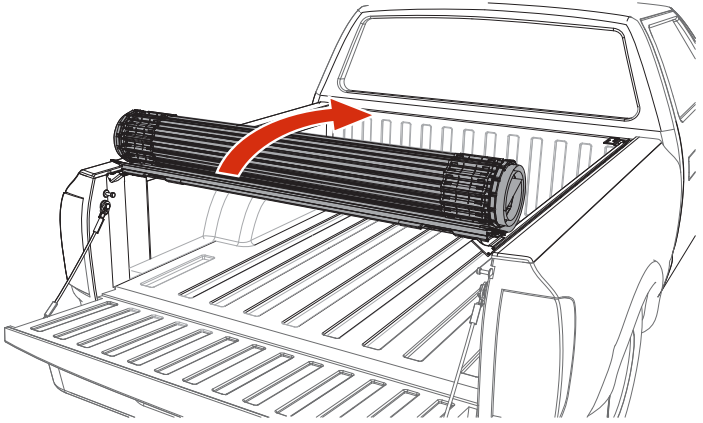

7

Roll the cover forward toward the cab, fold the front panel back and insert the two mounting bolts (I) into the slotted bracket, do this for both sides. The bolts will align with the slotted bracket of the cover rail. Fold the panel back down.

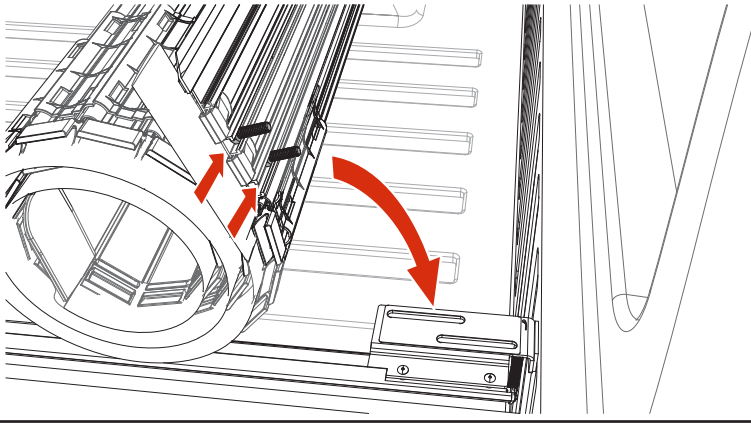

8

Install the mounting hardware loosely underneath the slotted bracket on the passenger cover rail. Start with the rubber washer (H), then the large flat washer (G), then hand tighten the knobs (F). Repeat on the driver side. Leave the knobs loose for now.

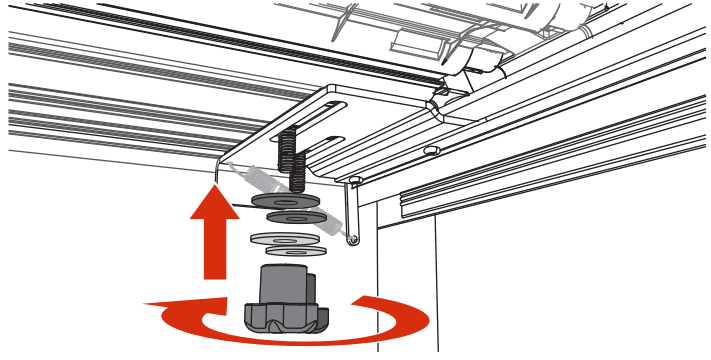

9 Open and close the cover several times to verify that it rolls freely. The cover should be square with the cover rails and roll freely between the rails.

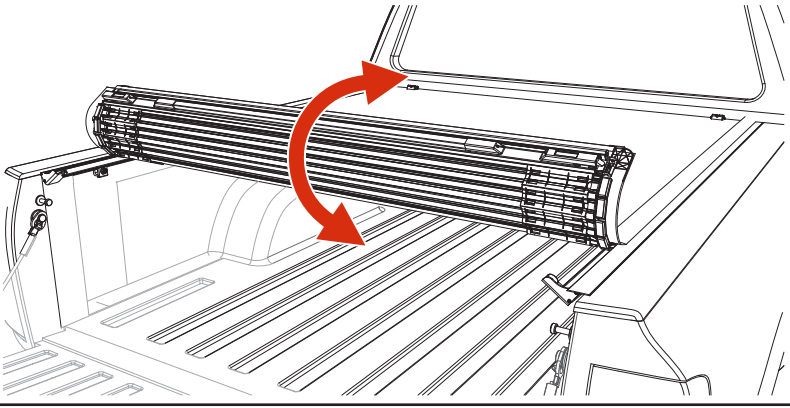

10 Align the front vinyl edge of the cover with the front edge of the cover rails (not the rubber seal).

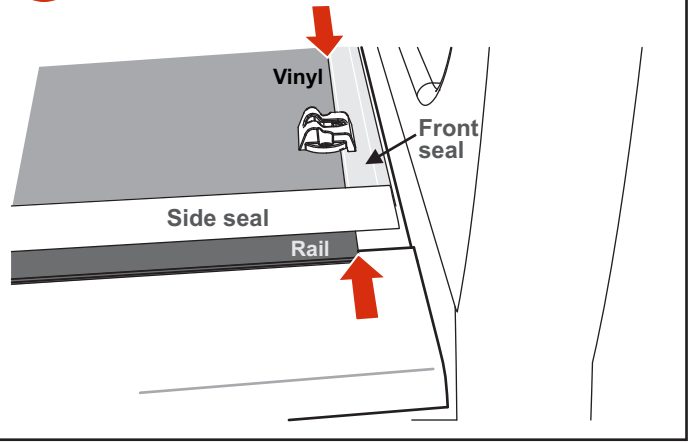

11 Verify that a gap of approximately 1/8" (3.2mm) remains on both sides of the cover between the edge of the cover rail and the rolling cover. This spacing is necessary to ensure that the locking rail secures to cover. Align the cover side to side at the front and/or the back if the side gaps are not even. Firmly hand tighten the knobs (F) after the cover has been aligned.

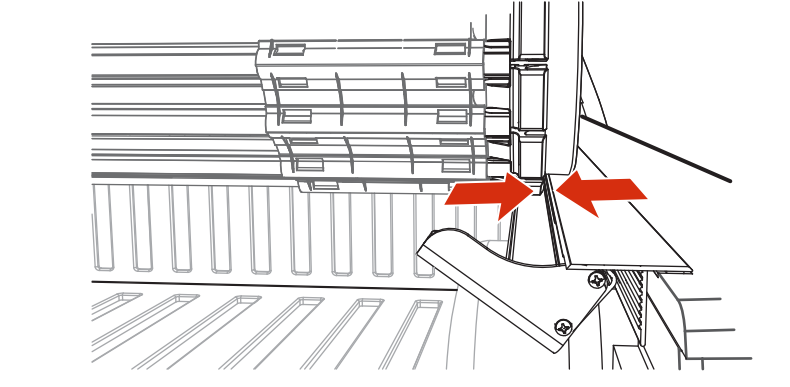

NOTE: On some applications shims may come pre-applied on the cover rails. If the cover has more than a 1/8" (3.2mm) gap as noted in step 11, you may require additional shims. Contact Customer Service at 818-365-9000.

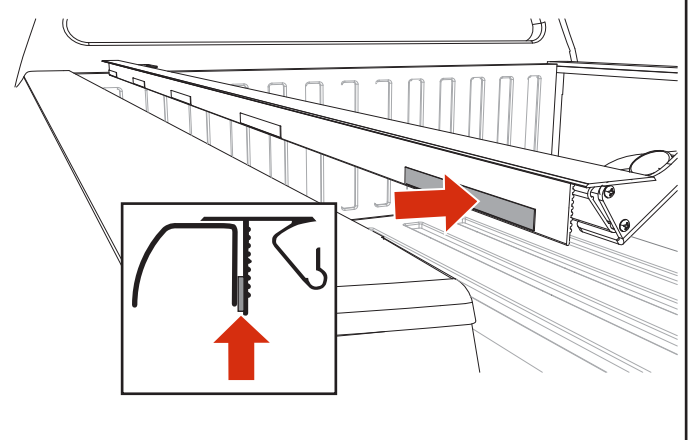

IMPORTANT: In order for the cover to operate properly the cover rails **MUST** be square (90° angle) to the truck bed rails. This allows the rear latch to engage accurately. Please find your truck style to the left to see how shims are pre-applied to achieve a level bed rail on different trucks.

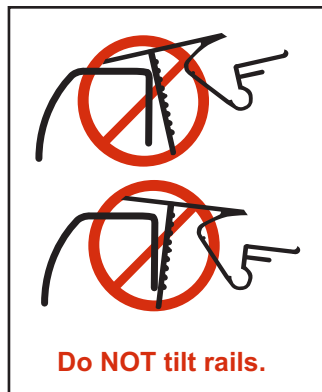
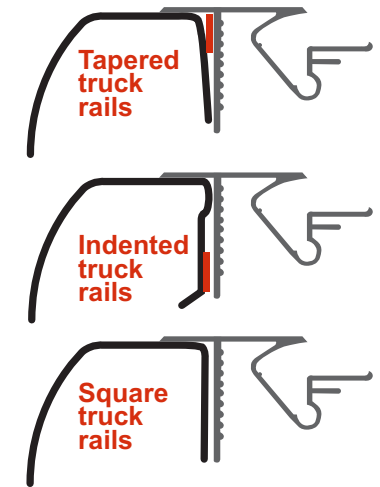

12 When correctly installed, the vinyl edges of the cover will align squarely with the cover rails in all four corners. The latch assembly will align with the rail locking levers at the tailgate on both sides.

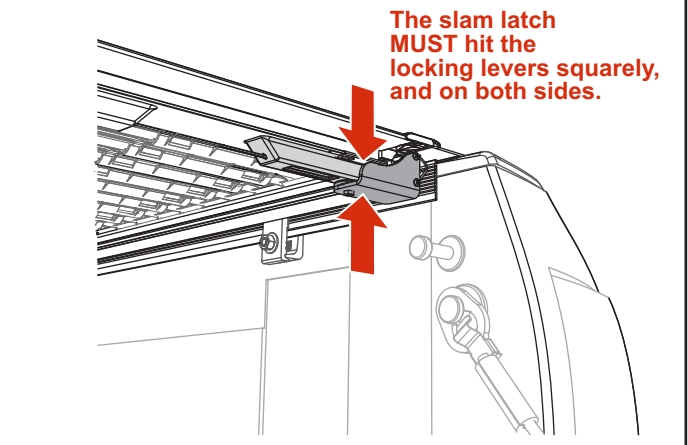

- 13** Check to see that the latches on both sides at the tailgate fully engage the cover rails. Loosening the knobs and making the side to side adjustment as in step 11 could help with the latch striker engagement. Shims as noted on the previous page may also help with rail alignment and latch engagement.

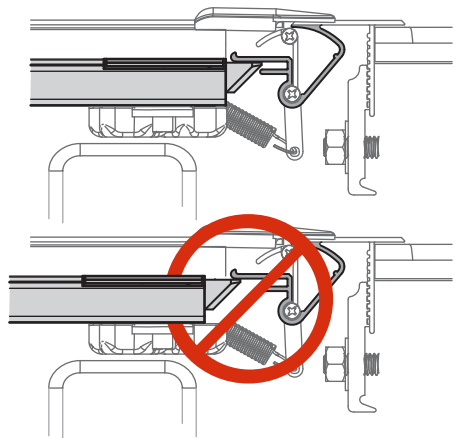

- 14** When the cover is properly aligned, roll the cover open, ensuring not to misalign while opening, tighten the knobs on both sides to secure the cover. **DO NOT** overtighten. Hand tighten only. Recheck that the cover operates correctly. Close the cover and check that the locking levers are engaged and prevent the cover from being lifted on both sides.

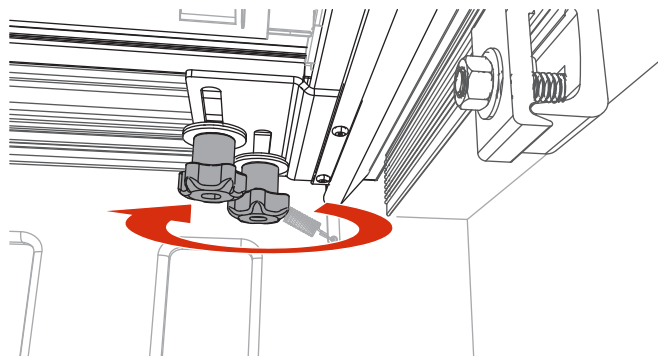

- 15** Mount the strap clamps (J) as far forward as possible on both the passenger and driver sides. Hand tighten to 10 ft/lbs of torque with a 9/16" wrench or socket.

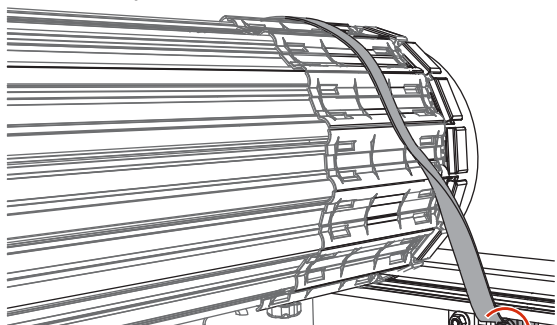

Always make sure that the clamps are inserted as far up onto the cover rail as possible and that the clamp teeth fit squarely and fully engage the ribs of the cover rail.

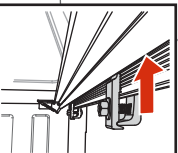

CAUTION: over tightening the clamps could cause warping of the bed cap.

- 16** The other end of the strap inserts into the cover clasp and turns to lock.

Pull up on the strap end to tighten

Always hook the straps on both sides.

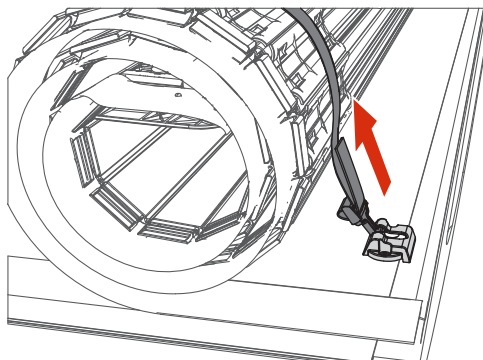
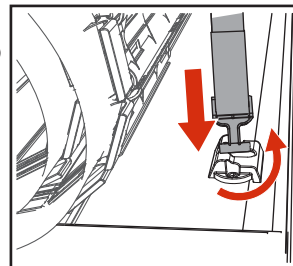

- 17** With the cover rolled open, remove the paper backing from the four D-shaped bumpers (K), clean the surfaces and adhere the bumpers to the cover slats. Position the bumpers so that they prevent the cover from contacting the cab. The straps will secure the cover away from the cab and glass.

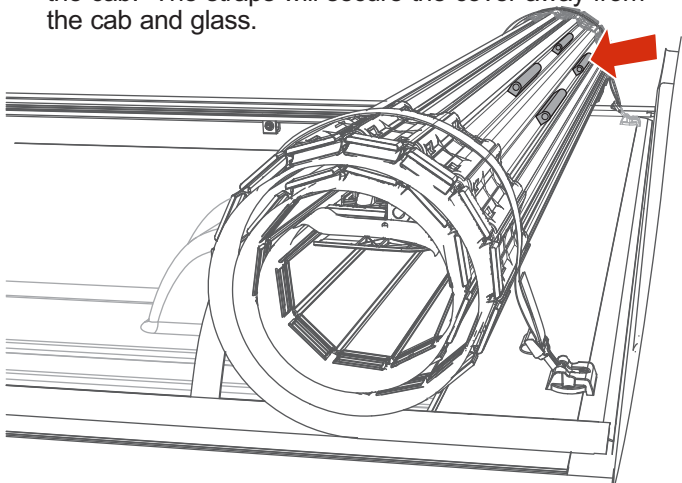

- 18** If the side seals of the cover appear wrinkled, exposure to the sun will assist the seals to lay flat. Applying heat with a hair dryer or carefully with a heat gun will also smooth the seals.

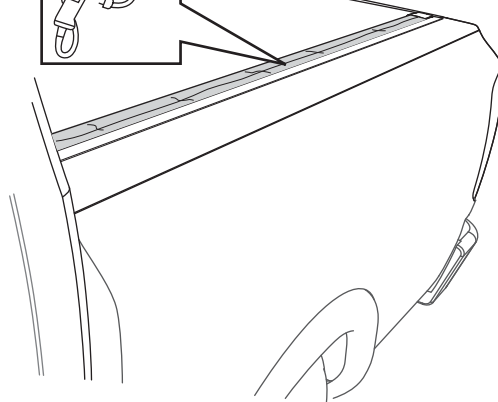
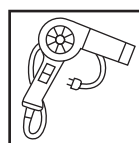

IMPORTANT Safe operation and use

IMPORTANT NOTICE

While driving, cover must be completely flat and secure with BOTH rear latches engaged and in the closed position OR completely rolled up and secured at the cab with the provided straps. **DO NOT DRIVE** with cover partially opened.

Truck Bed Cover Positions While Operating Vehicle

Prior to vehicle operation, the truck bed cover MUST be properly secured.

CLOSED POSITION (FIG 1)

Cover must be closed and **FULLY LATCHED ON BOTH SIDES** of the cover side rails.

OPEN POSITION (FIG 2)

To drive with the cover in the open position, use the strap clamps. Roll the cover forward, twist and insert the clips into the cover clasps. Ensure that **BOTH** strap clamps are fully inserted into the clasps, pull on the end of the strap to tighten.

Cover Operation

TO CLOSE THE COVER (FIG 3)

Roll the top toward the tailgate and rotate the tail rail downwards towards the rotating locking levers.

WARNING – When closing the cover ensure rear latches on **BOTH** sides are fully engaged underneath the cover rails before operating the vehicle.

TO OPEN THE COVER (FIG 4)

Pull down on the latch release cable located on either side of the cover and rotate the tail rail forward and into a rolling motion. When driving with the cover open, the cover must be rolled toward the cab and secured with both strap clamps.

DO NOT ATTEMPT TO DRIVE WITH THE COVER IN THE PARTIALLY OPEN POSITION!

ADDITIONAL IMPORTANT OPERATING TIPS

- Truck bed cover **MUST** be free of foreign material including snow and ice before opening rail top.
- Do **NOT** tow your vehicle from the rear with the tonneau on your truck.
- Do **NOT** operate vehicle with objects on top of cover.

FAILURE TO FOLLOW THESE CAUTIONS MAY RESULT IN SEVERE DAMAGE AND WILL VOID YOUR WARRANTY!

Fig. 1
Closed position

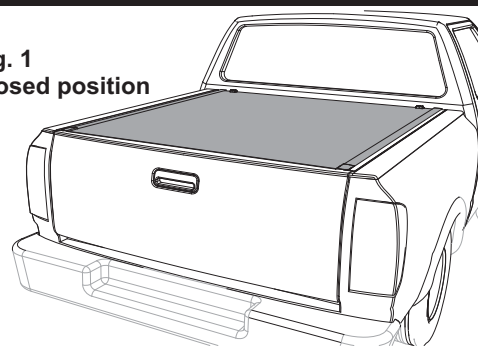

Fig. 2
Open position

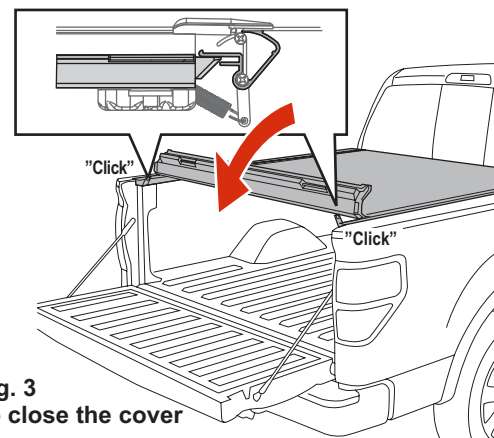
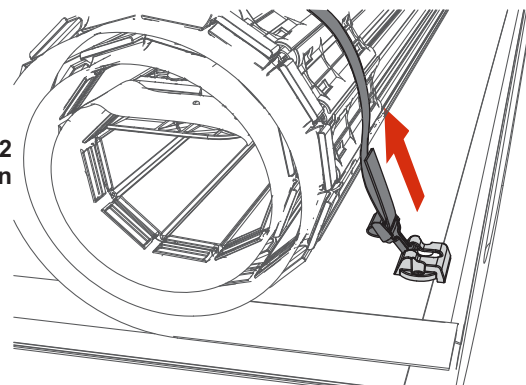
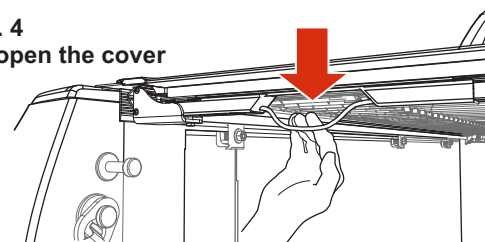

Fig. 3
To close the cover

Fig. 4
To open the cover



Remove all foreign matter before rolling the cover.



Do **NOT** tow your vehicle from the rear with this cover on your truck.

Warranty

BAK® Industries (“BAK”) warrants your Revolver Hard Rolling Cover to be structurally free from defects in material and workmanship for the period as outlined in the table below from the retail date of purchase. Warranty registration must be on file and/or proof of original purchase (detailed and dated receipt) required for warranty service. Warranty is non-transferable and applies to the original purchaser of the BAK product only.

PRODUCT	WARRANTY PERIOD	REGISTER YOUR WARRANTY NOW AT BAKINDUSTRIES.COM	
Revolver X2	3 Year Limited Warranty		
Revolver X4s	5 Year Limited Warranty		

BAK reserves the right to determine whether a product needs to be repaired or replaced. No labor or service allowance is given or implied. The warranty will be void if the product has been damaged by accident, unreasonable use, neglect, improper service/installation/removal, modifications, acts of God or normal wear and tear or other causes not arising out of defective materials or workmanship. BAK assumes no liability for injury, loss, incidental or consequential damages. BAK reserves the right to substitute an entire replacement system or provide other remedies than those listed in this warranty for discontinued products or other reasons. Shipping charges will apply for any repair or replacement.

Improper cleaning may also void your warranty. It is recommended to use the approved BAK treatment of the vinyl as outlined below or clean with soap and water only. Do not use vinyl conditioners (i.e. Armor All®) because they will shrink the vinyl.

BAK is committed to providing you with our best service at all times. Please feel free to contact us should you require any assistance with your BAK product.

CARE AND MAINTENANCE

The bed covers are made from durable materials and require simple care to ensure a long life of performing well and looking great.

Cleaning the Top (Washing)

These stylish covers incorporate OE marine grade vinyl laminated on the top surfaces. Standard automotive soap and water used with a soft sponge or cloth is recommended for cleaning. Shammy dry to prevent water spots and ensure a rich dark finish.

Treating the Vinyl Top

303® Aerospace Protectant may be used to keep the vinyl surface clean and protected from the elements and will also remove any water spots that may have developed. 303 Aerospace not only protects against fading, discoloration and cracking from harmful UV rays, but repels dust and stains. Simply spray on and wipe dry for a beautiful, matte finish that protects your cover from road grime and dust. Do not use vinyl conditioners (i.e. Armor All®) because they will shrink the vinyl.

Maintenance

It is recommended that you periodically check that the cover is securely attached to your truck bed. Inspect the clamps and front mounting bolts to ensure they were properly installed and have not come loose or knocked out of adjustment during operation. Covers that are used with high frequency or that are subject to the vibrations and impact from rough roadways can cause the cover to require adjustment.

Lubricating the Latches

It is recommended that you periodically inspect and service the latches on the end of the roll top. Clean away any excess dirt or grime and use a spray lubricant. Ensure the latches move freely in and out to properly engage the side rail and provide proper performance with optimum security. Be careful not to overspray the cover. Wipe away any excess around the latch location.