

with Installation Instructions
Owner's Manual

Module Mounting Bracket Kit

**For Derringer & 4ch Analog, 4ch Thermocouple,
and 5ch Analog with Frequency Modules.**

THIS MANUAL IS FOR USE WITH THE FOLLOWING PART NUMBERS:
66423 - MOUNTING BRACKET KIT FOR BANKS MODULES

banks

General Installation Practices

Dear Customer,

If you have any questions concerning the installation of your module mounting bracket kit, please call our Technical Service Hotline. Watching our how-to video (link on the cover) may alleviate any further questions. If you have any questions relating to shipping or billing, please contact our Customer Service Department.

Thank you.

1. Before starting work, familiarize yourself with the installation procedure by reading all of the instructions.
2. The exploded view (**Figure 1**) provides only general guidance. Refer to each step and section diagram in this manual for proper instruction.
3. Throughout this manual, the left side of the vehicle refers to the driver's side, and the right side to the passenger's side.
4. Disconnect the negative (ground) cable from the battery (or batteries, if there are two) before beginning work.
5. Route and tie wires and hoses a minimum of 6" away from exhaust heat, moving parts and sharp edges. Clearance of 8" or more is recommended where possible.
6. When raising the vehicle, support it on properly weight-rated safety stands, ramps or a commercial hoist. Follow the manufacturer's safety

precautions. Take care to balance the vehicle to prevent it from slipping or falling. When using ramps, be sure the front wheels are centered squarely on the topsides; put the transmission in park; set the hand brake; and place blocks behind the rear wheels.

CAUTION! Do not use floor jacks to support the vehicle while working under it. Do not raise the vehicle onto concrete blocks, masonry or any other item not intended specifically for this use.

7. During installation, keep the work area clean. Do not allow anything to be dropped into intake, exhaust, or lubrication system components while performing the installation, as foreign objects will cause immediate engine damage upon start-up.

Tools Required:

- Hand drill or powerdrill
- #21 or 9/64" drill bit
- Marker

Section 1: Included Parts

Figure 1 Banks Module Mounting Bracket Kit

| Item # | Description | Part # | QTY |
|--------|---|----------|-----|
| 1 | Mounting Bracket, BB-III Module | 61300-05 | 1 |
| 2 | Screw, Sheet Metal - #10 x 1/2", Phillips | 91872 | 2 |

Figure 1

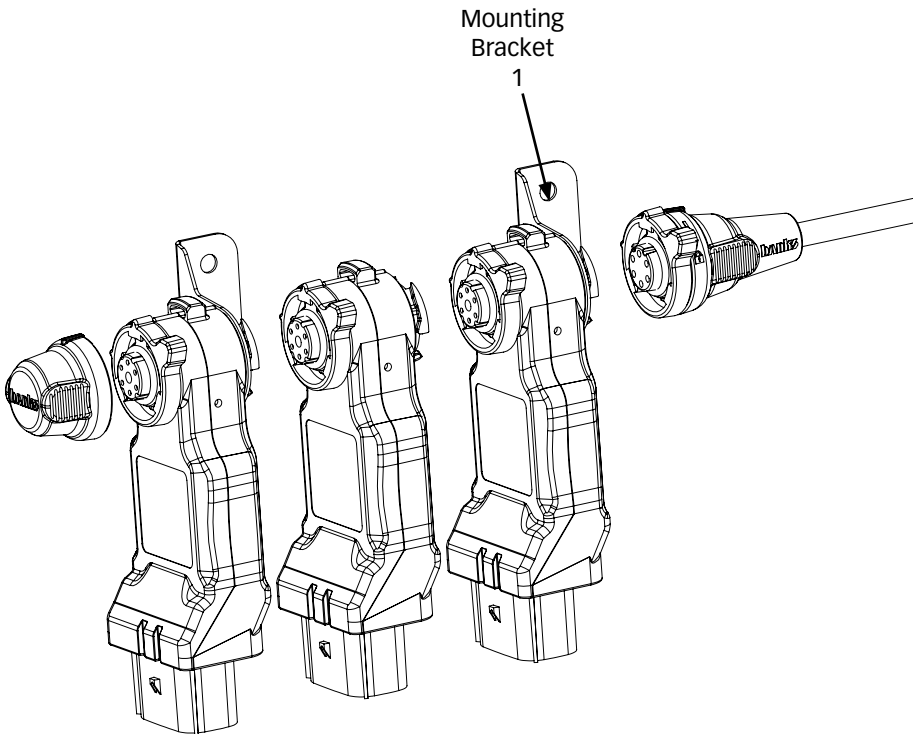

Installation

1. See Figure 2.

Figure 2

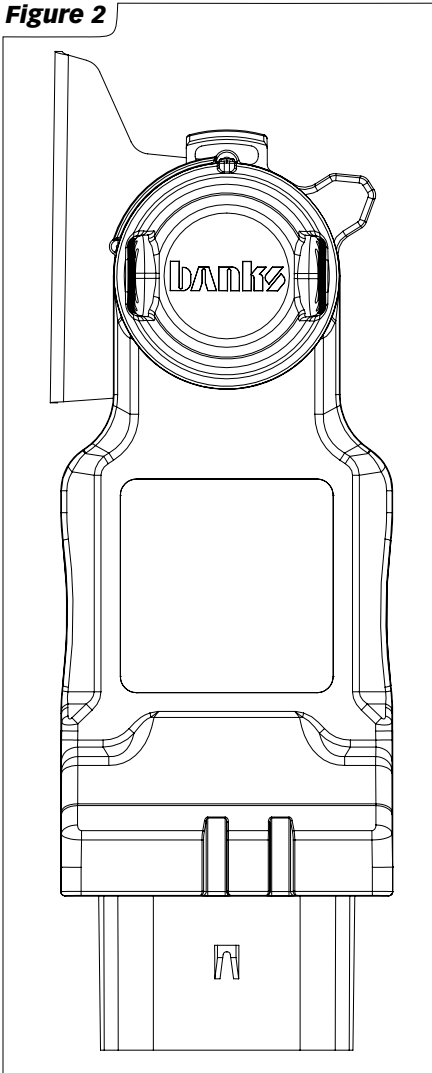

2. Recommended number of brackets:

- 1-2 modules: 1 bracket
- 3-4 modules: 2 brackets
- 5-6 modules: 3 brackets
- 7+ modules: 4 brackets

3. If using Gen-1 Derringer Module, be sure to place it closest to the cable coming from the firewall, or first amongst all the modules to be mounted. As shown in **Figure 3**.

Figure 3

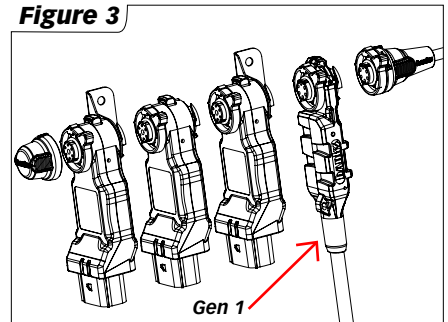

4. To unlock the module(s), rotate the knob into the 3 o'clock position with the alignment marks aligned in the 12 o'clock position, as shown in **Figure 4**. To lock modules once installed onto brackets, rotate the knob clockwise. The knob will slightly "click" once near the locked position, with a final audible "click" once fully locked. The alignment marks will once again be fully aligned in the 12 o'clock position, as show in **Figure 4**.

Figure 4

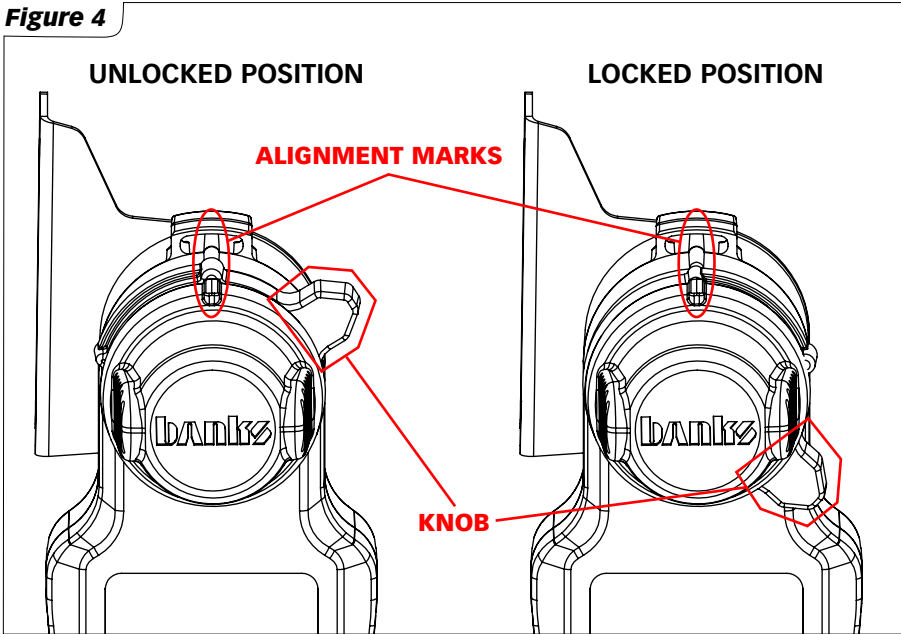

Templates

Cut off and use these templates to mark correct drill hole spacing prior to drilling holes for the #10 screws.

Please note: Use template 2 if you are using a Gen 1 Derringer (See **Figure 3)*

