

banks

with Installation Instructions
Owner's Manual

Banks Monster[®]
Exhaust System

07-11 Jeep 3.8L Wrangler

THIS MANUAL IS FOR USE WITH MONSTER EXHAUST SYSTEMS 51321, 51322

BANKS

General Installation Practices

1. Before starting work, familiarize yourself with the installation procedure by reading all of the instructions.

2. The exploded view (**Figure 1**) provides only general guidance. Refer to each step and section diagram in this manual for proper instruction.

3. Throughout this manual, the left side of the vehicle refers to the driver's side, and the right side to the passenger's side.

4. Disconnect the negative (ground) cable from the battery (or batteries, if there are two) before beginning work.

5. Route and tie wires and hoses a minimum of 6" away from exhaust heat, moving parts and sharp edges. Clearance of 8" or more is recommended where possible.

6. When raising the vehicle, support it on properly weight-rated safety stands, ramps or a commercial hoist. Follow the manufacturer's safety precautions. Take care to balance the vehicle to prevent it from slipping or falling.

When using ramps, be sure the front wheels are centered squarely on the topsides. When raising the front of the vehicle, put the transmission in park, set the parking brake, and block the rear wheels. When raising the back of the vehicle, be sure the vehicle is on level ground and the front wheels are blocked securely. **Caution! Do not use floor jacks to support the vehicle while working under it. Do not raise the vehicle onto concrete blocks, masonry or any other item not intended specifically for this use.**

7. During installation, keep the work area clean. Do not allow anything to be dropped into intake, exhaust, or lubrication system components while performing the installation, as foreign objects will cause immediate engine damage upon start-up.

Tools Required:

- 1/2" and 3/8" drive ratchets with standard and metric sockets and 1/2" and 3/8" drive extension
- Standard and metric combination or open-end wrenches
- Standard screwdriver
- Clean shop towels or rags
- Pry-bar

Highly recommended tools and supplies:

- Foot-pound torque wrench
- Penetrating oil or light lubricant spray

Also Available from Banks Power



Banks Ram-Air Intake System (P/N 41832)

- Increases your airflow over stock.
- Adds power, improves fuel economy, lowers EGTs and reduces smoke.

General Assembly

Figure 1

Item #	Description	P/N	QTY
1a	2-door Intermediate Pipe (95" WB)	52644	1
1b	4-door Extension Pipe (116" WB)	52645	1
2	Front Tailpipe	52646	1
3	Monster Muffler	52639	1
4	Rear Tailpipe	52647	1
5	Tailpipe Tip, Chrome/Black	52700/52701	1
6	Saddle Clamp, 2.5"	52461	*
7	Band Clamp, 2.5"	52462	1
8	Banks Decal	96009	2

*System 51321 contains 4 Item # 6 & system 51322 contains 5 Item #6

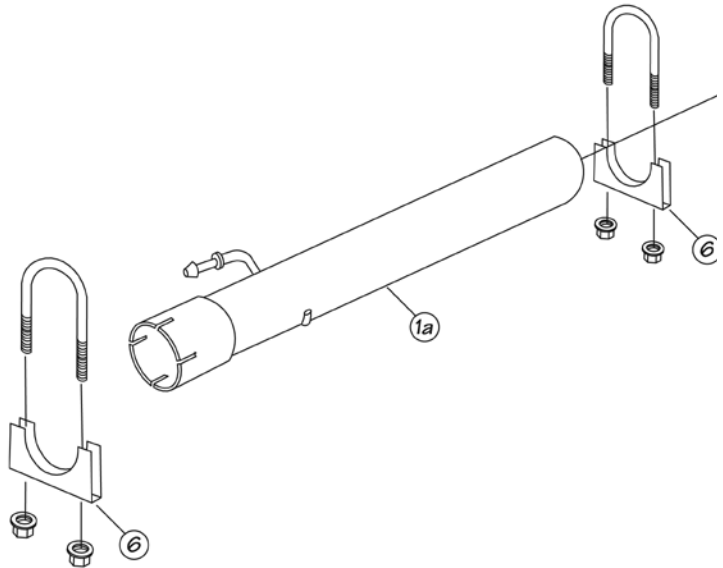

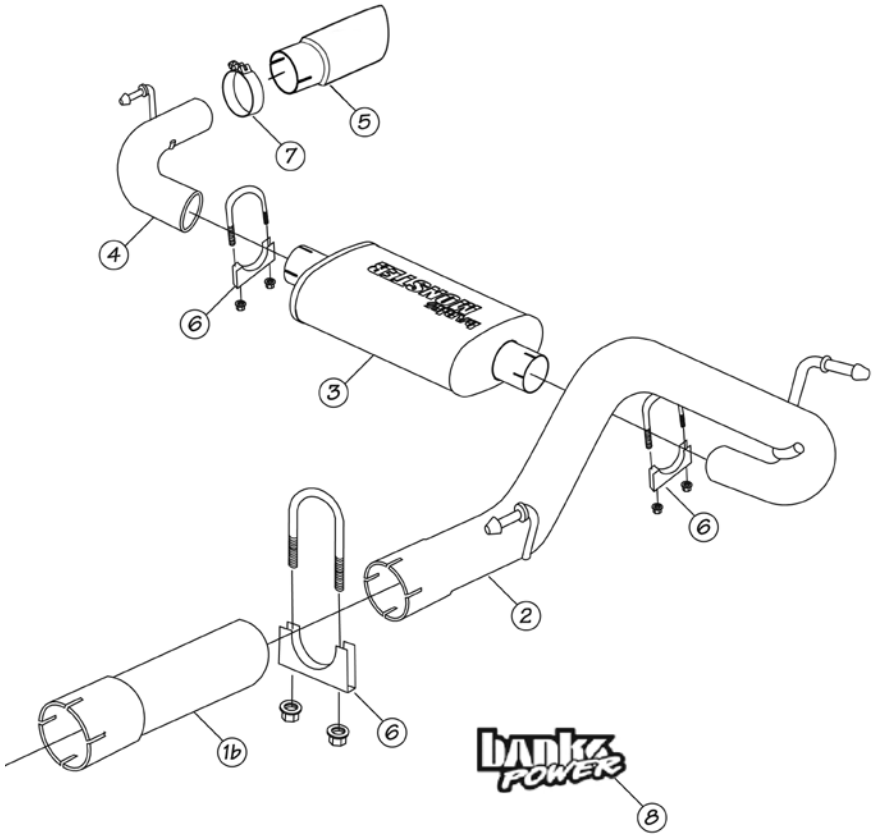

Monster Exhaust System Installation

1. Disconnect the negative (ground) cable from the battery (if there is more than one battery, disconnect both negative cables). Secure the cable so it cannot accidentally come in contact with the post.

2. Raise the vehicle and support it securely with properly weight-rated safety stands, ramps or a commercial hoist. Take care to balance the vehicle to prevent it from slipping or falling. When using ramps, be sure the wheels are centered squarely on the topsides. Place the transmission in park (automatic), set the parking brake and securely block the wheels that are on the ground. **CAUTION: DO NOT WORK UNDER ANY VEHICLE SUPPORTED ONLY BY A JACK. SEVERE INJURY MAY RESULT.**

3. Loosen and remove the 2.5" factory clamp after the y-pipe. Remove the rear muffler hanger pin from the rubber hanger. Remove the front muffler hanger pin from the rubber hanger (See **Figure 2**).

NOTE: Spray lubricant may assist in hanger pin removal. Rubber hangers can also be removed from the vehicle to assist in tailpipe / muffler removal.

4. Remove the tailpipe and intermediate pipe hanger pins from the rubber hangers. Remove the tailpipe, muffler and intermediate pipe assembly from the vehicle

5. Place a 2.5" saddle clamp on the inlet of the Banks intermediate pipe. Install the intermediate pipe onto the factory y-pipe outlet. Insert the Banks

Figure 2

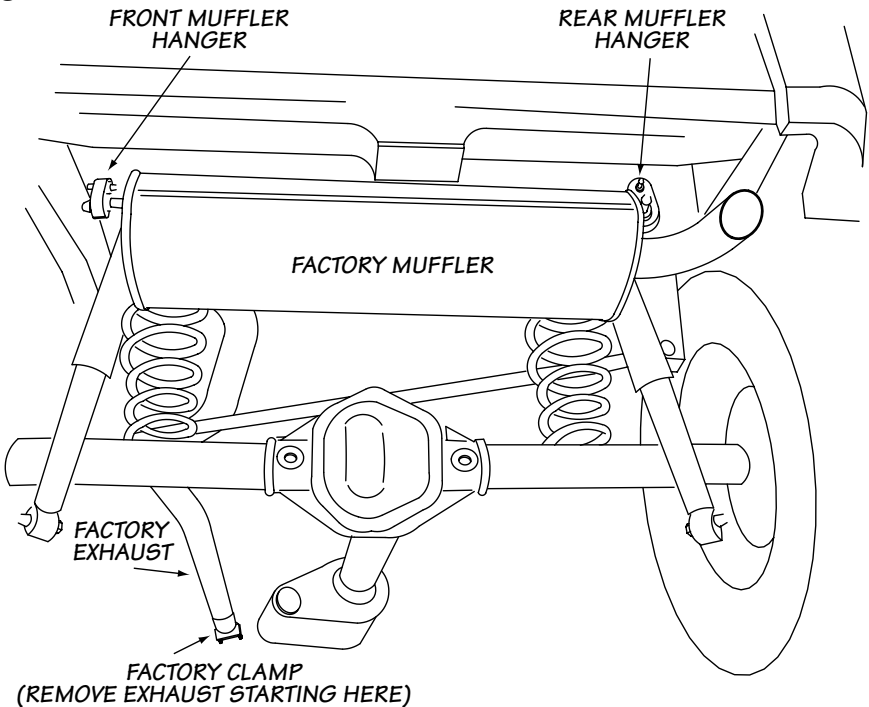

hanger pin into the vehicle's rubber hanger. Loosely tighten the 2.5" clamp.

NOTE: All clamps should be positioned at the beginning of the slots (on the 1/2 circle punch).

NOTE: Once the pipe / muffler has been completely engaged in the slip joint, mark the pipe with a scribe or tape for reference when tightening the clamps later in the installation. Mark each slip joint in this fashion.

6. If you have a 4-door wrangler, place a 2.5" saddle clamp on inlet of the extension pipe. install the extension pipe onto the intermediate pipe outlet. Loosely tighten the 2.5" clamp

7. Place a 2.5" saddle clamp on the inlet of the Banks front tailpipe. From the vehicle rear, route the tailpipe over

the rear end. Install the tailpipe onto the intermediate pipe outlet. Insert the Banks two (2) hanger pins into the vehicle's rubber hangers. Loosely tighten the 2.5" clamp.

8. Place a 2.5" saddle clamp on the inlet of the Monster Muffler. (Note the inlet labeling of the muffler) Install the Monster Muffler onto the front tailpipe. Orient the Monster Muffler such that is parallel with the cab and the Monster logo is visible once the exhaust is installed. Loosely tighten the 2.5" clamp (See **Figure 3**)

9. Place a 2.5" saddle clamp on the outlet of the Monster Muffler. Install the rear tailpipe into the Monster muffler. Insert the Banks hanger pin into the vehicle's rubber hanger. Adjust the tailpipe so that is straight

Figure 3

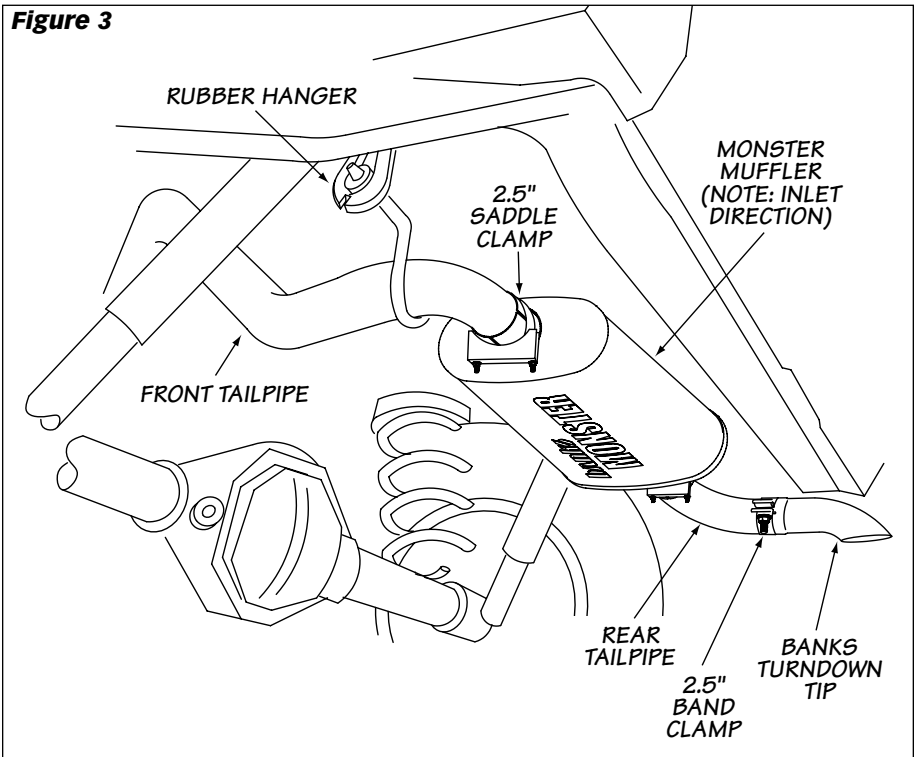

and flat under rear bumper. Loosely tighten the 2.5" clamp.

10. Install the 2.5" band clamp onto the tailpipe tip inlet. Install the tip and clamp assembly onto the tailpipe outlet. Adjust the tip to be flat under the body panel, such that the tip position is aesthetically pleasing (See **Figure 3**).

11. Adjust each of the pipes to ensure that all of the hanger pins are parallel with the frame mounted pins and that the rubber hangers are all positioned slightly forward (See **Figure 4**). This allows the hangers to be properly positioned once the exhaust reaches operating temperature.

12. With the exhaust positioned properly, begin to evenly tighten the clamps starting with the ones closest to the front of the vehicle and working your way back. Torque the exhaust clamps evenly to 35 ft-lbs. Make sure that each slip is fully inserted (+/-1/4").

13. Remove the protective covering from the tailpipe tip.

Caution: the protective covering may ignite and burn if not removed prior to running the engine.

14. Your system includes two (2) Banks Power logos designed to complement the vehicle's front fenders. See **Figure 5** for recommended logo placement.

15. Re-connect the negative battery cable. Start the engine and listen for exhaust leaks. Tighten the exhaust clamps as necessary. Whenever possible, tack weld slip connections to prevent disengagement is recommended.

16. The Banks Monster Exhaust installation is now complete.

Figure 4

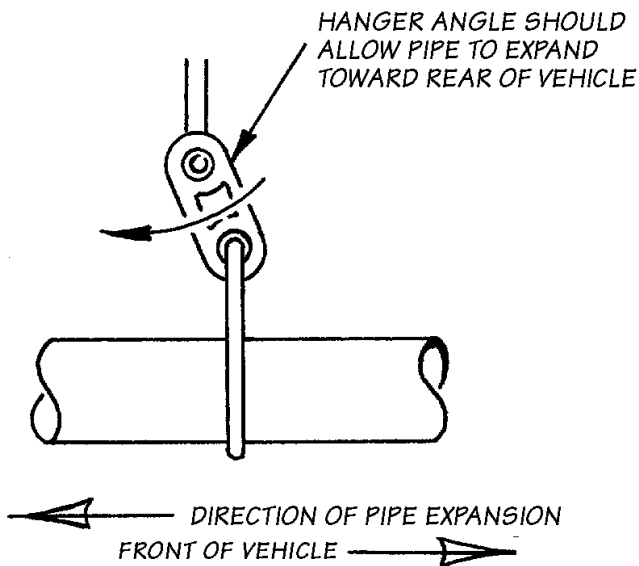

Figure 5

