



68RFE Thermostat Bypass

Transmission Cooler Line Thermostatic Valve Bypass Kit



1061528

2013-2018 RAM Truck with 68RFE

1061527

2019+ RAM Truck with 68RFE

Kit Contents

1061528 kit content		
1300580	1300579	1453153
		
Bypass Block Qty: 1	Quick Connect Fitting Qty: 2	O-ring Qty: 2

1061527 kit content		
1300581	1500402-SS	1453153
		
Bypass Block Qty: 1	Qty: 2	O-ring Qty: 2

Introduction

The stock cooler bypass valve allows transmission fluid to bypass the cooler and directly return to the transmission to quickly warm up the fluid. The problem is that debris from the transmission can jam the internal valve keeping the valve in the recirculation mode. When this happens the transmission temperature will rise and can lead to overheating and premature transmission failure.

Tools Required for Installation

- 1" open Wrench
- 15/16 or 24mm open wrench
- 20 mm open wrench
- Small flat screw driver or pick tool
- 10 mm open/close wrench

Installation 2013-2018

Raise and support the vehicle on a hoist or using jack stands.
Place a drain pan below the work area to catch any fluid spilled.

Undo both transmission cooler line nuts using 20mm and 24mm(15/16) open wrench and slide them back on the cooler line.

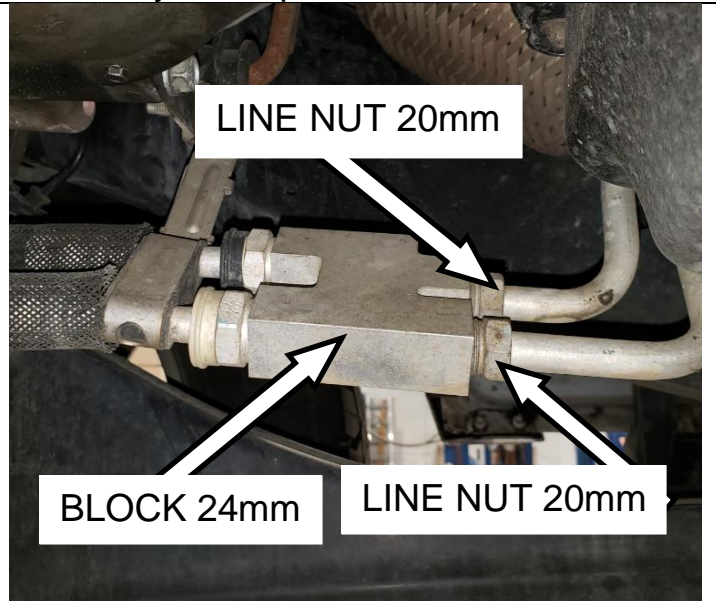

Remove both quick connect joint clips using pick tool

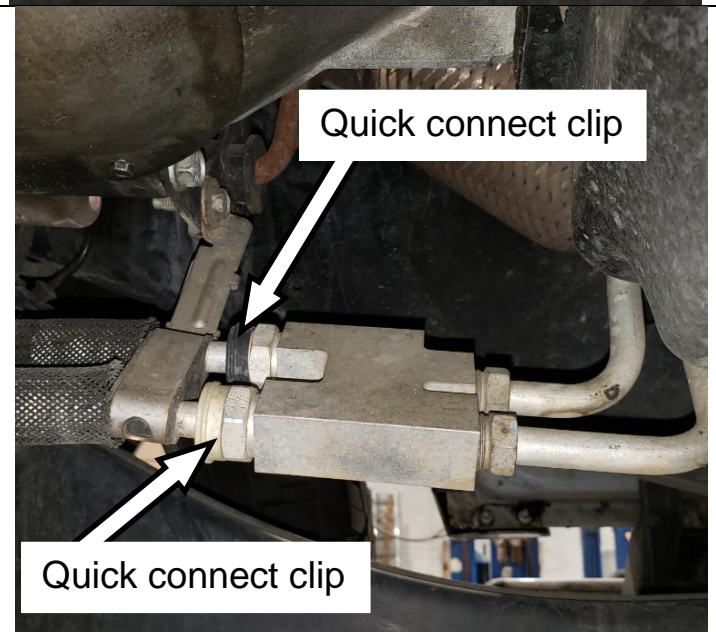

Pull out the cooler lines from cooler bypass block and collect drain trans oil

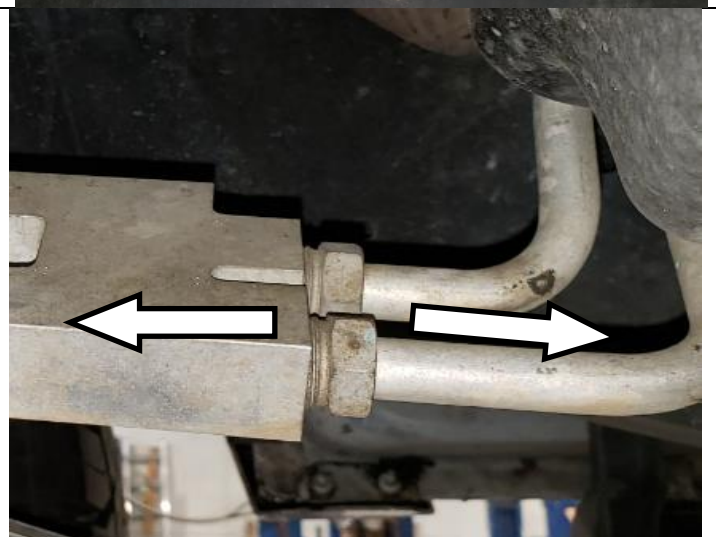

Pull cooler bypass block off of the quick connect lines

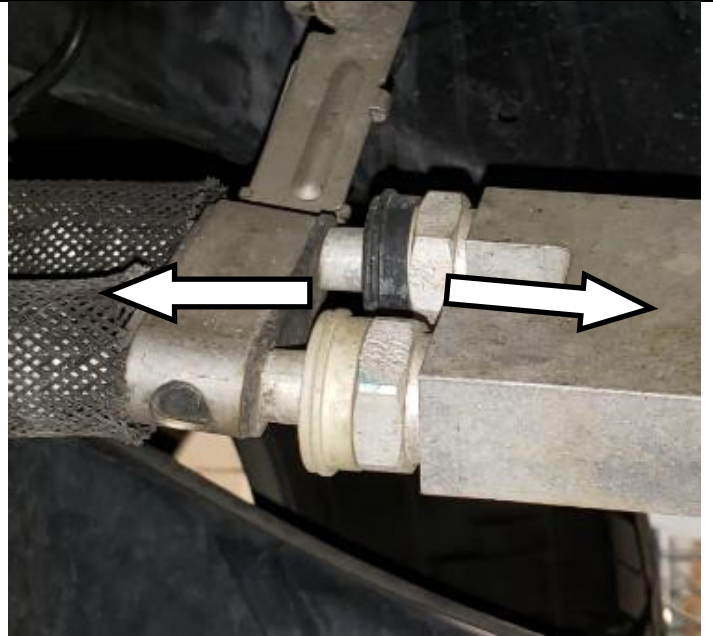

The original thermostat housing should now be removed. Clean the ends of the lines if needed to prevent debris contamination upon reassembly.



Put quick connect fitting (1300579) on thermal by pass block (1300580) using 1" and 24mm open wrench.

Torque Spec: 23-29 ft-lb

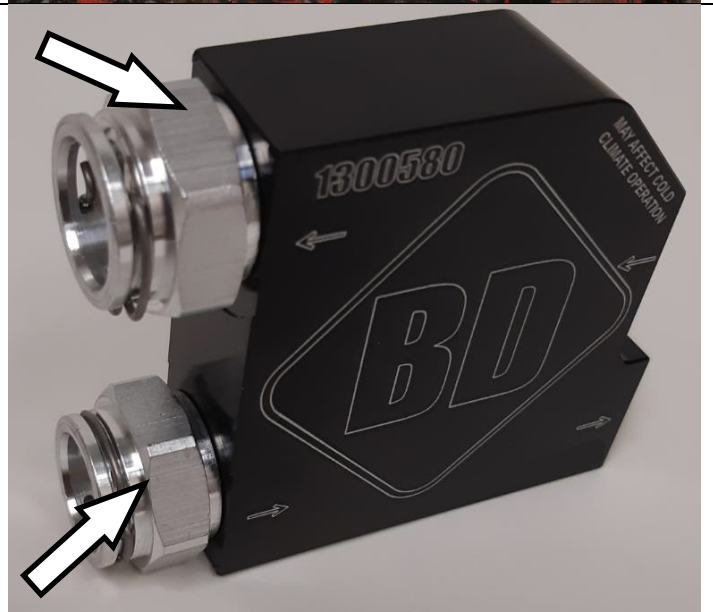

Lubricate the o-ring and clip using transmission lubricant



Align both quick connect ports with the transmission lines and push until the clip clicks in behind the flange on the quick connect fittings



Inspect original O-ring on the tube, replace with supplied viton O-ring (1453153) if it is damaged.

Reinstall both transmission cooler lines in to threaded end of the block, wiggle the lines and nut to start the threads. Tighten nuts 24 lb-ft.

Correct transmission fluid level and check for possible leakage.



Installation 2019+

For 2019+ Vehicles Only:

Undo both transmission cooler line nuts using 20mm and 24mm(15/16) open wrenches and slide them back on the cooler line.

Undo M8 bolt using 10mm wrench

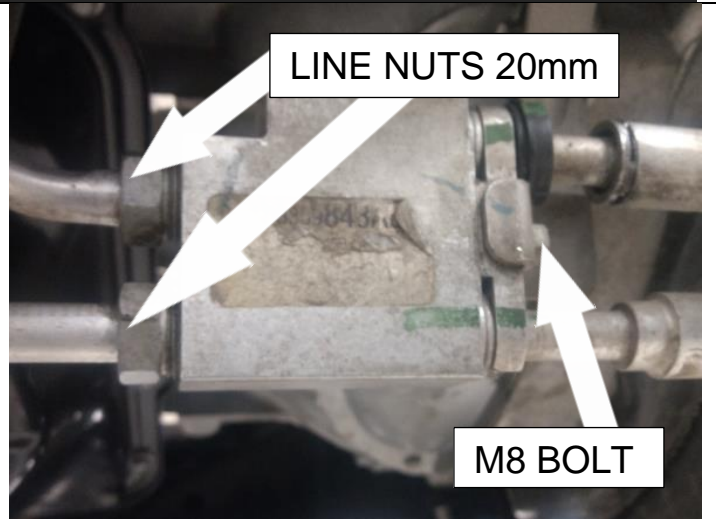

Pull out the cooler lines from cooler bypass block and collect the leaking oil with a drain pan

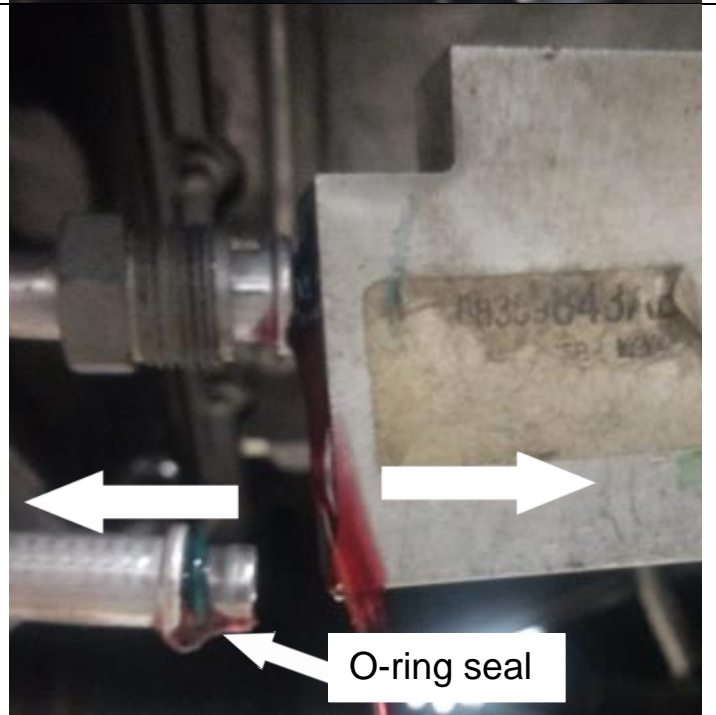

Pull the cooler bypass block off of the bracket to disconnect the lines

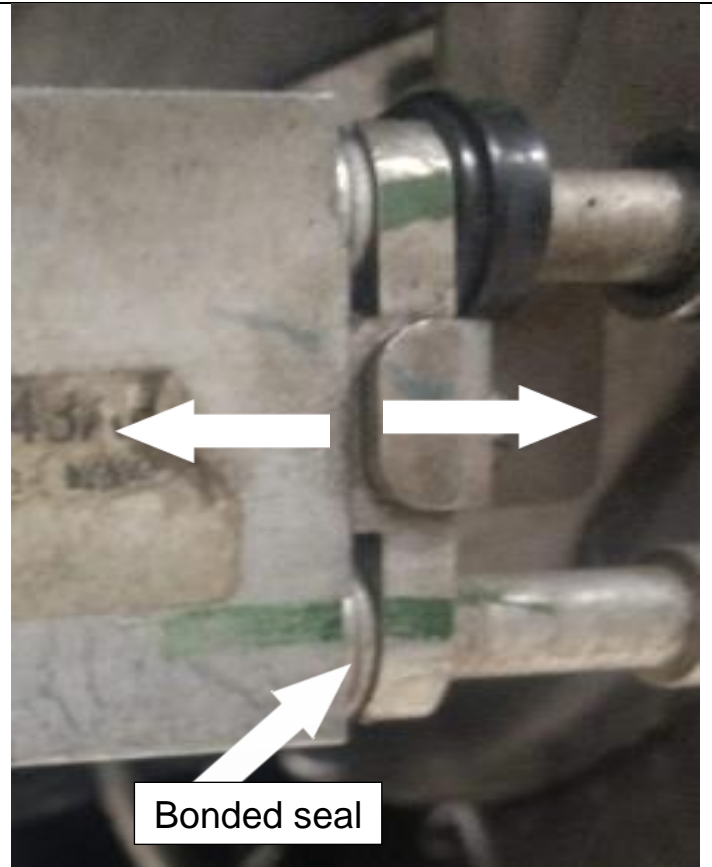

Inspect original O-ring on the tube, replace with supplied viton O-ring (1453153) if it is damaged.

Inspect bonded seal, replace with supplied bonded seal (1500402-SS) if it is damaged.

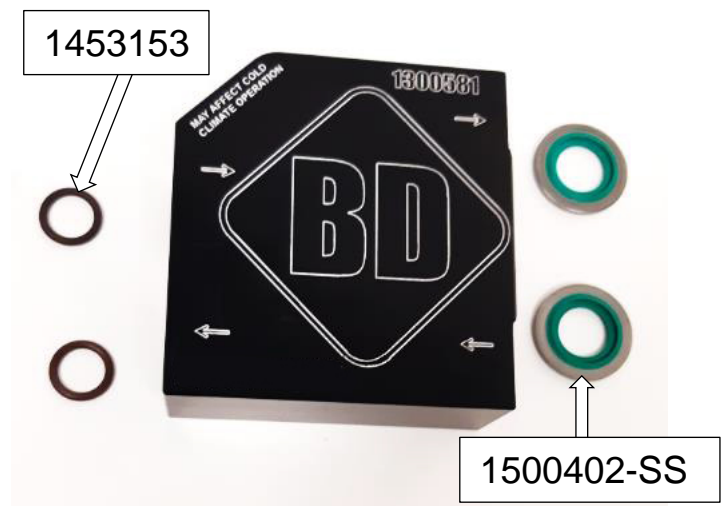

Align both tubes with bracket and the holes on the block and hand tight the M8 bolt.
And tighten the M8 bolt using 10mm wrench torque 13 lb-ft

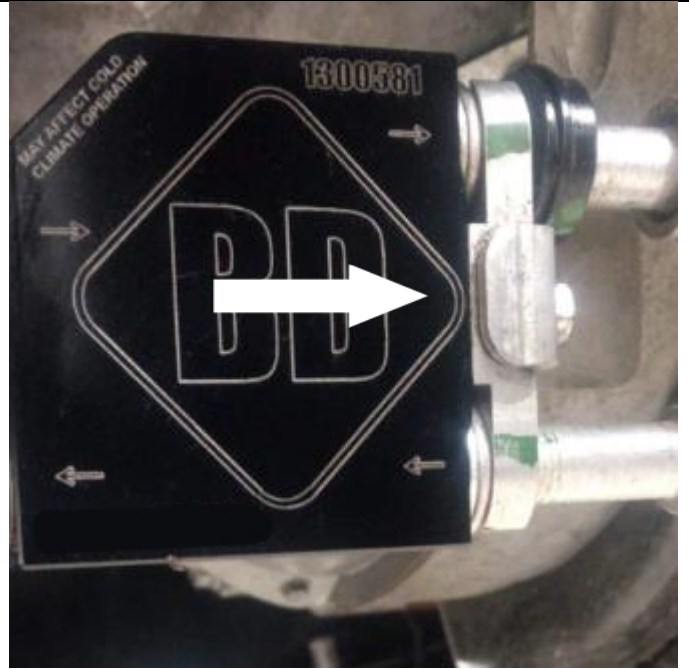

Reinstall both transmission cooler lines in to threaded end of the block, wiggle the lines and nut to start the threads.
Tighten nuts 24 lb-ft.

Correct transmission fluid level and check for possible leakage.

