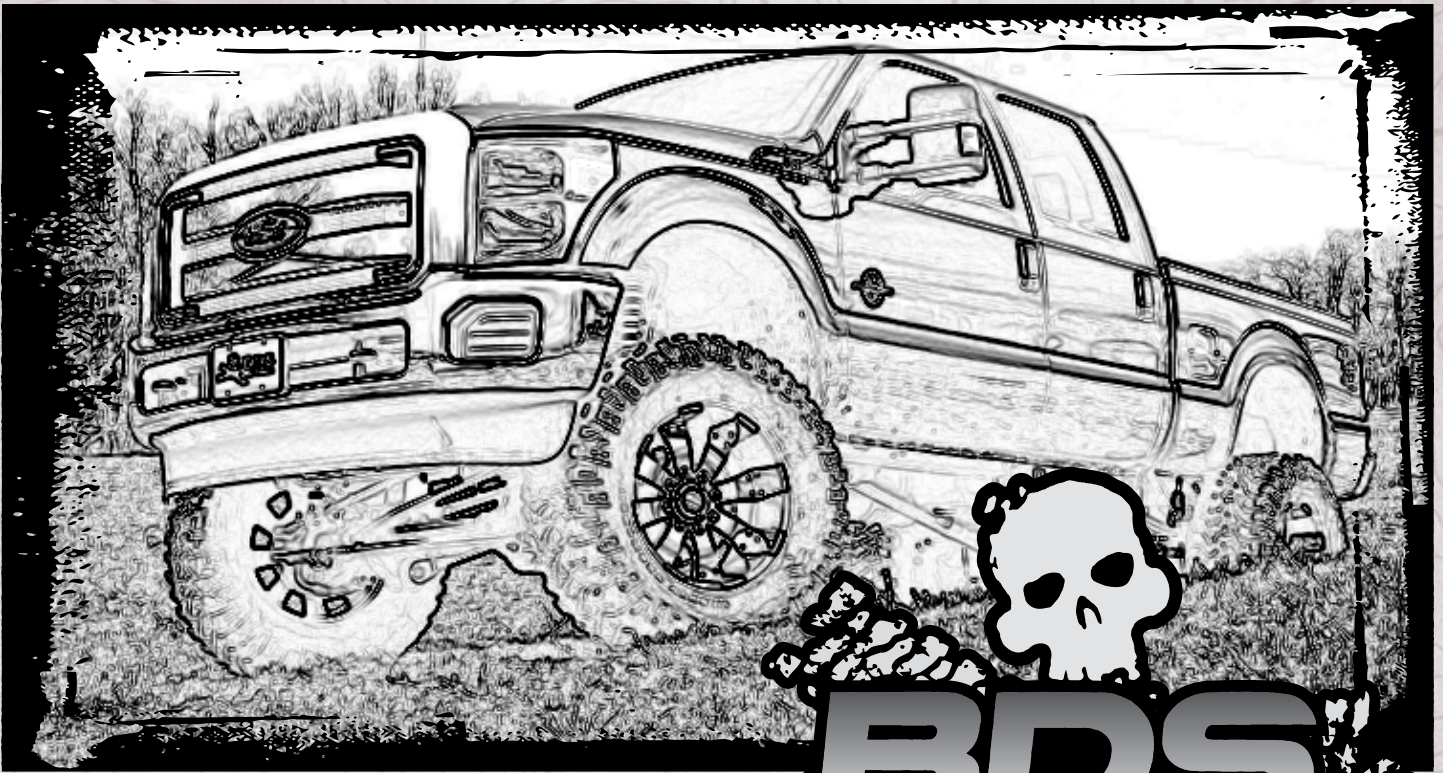


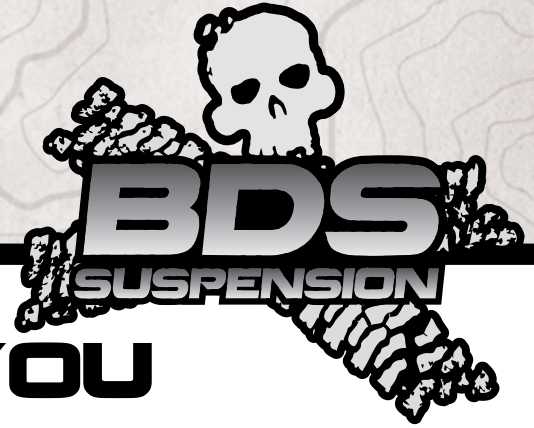
Installation instructions



Part#: 123408, 123409

**Ford Super Duty Recoil
Traction Bar System**

Read And Understand All Instructions And Warnings Prior To Installation Of System And Operation Of Vehicle.



THANK YOU

Your truck is about to be fitted with the best suspension system on the market today. That means you will be driving the baddest looking truck in the neighborhood, and you'll have the warranty to ensure that it stays that way for years to come. Thank you for choosing BDS Suspension!

BEFORE YOU START

BDS Suspension Co. recommends this system be installed by a professional technician. In addition to these instructions, professional knowledge of disassembly/ reassembly procedures and post installation checks must be known.

FOR YOUR SAFETY

Certain BDS Suspension products are intended to improve off-road performance. Modifying your vehicle for off-road use may result in the vehicle handling differently than a factory equipped vehicle. Extreme care must be used to prevent loss of control or vehicle rollover. Failure to drive your modified vehicle safely may result in serious injury or death. BDS Suspension Co. does not recommend the combined use of suspension lifts, body lifts, or other lifting devices. You should never operate your modified vehicle under the influence of alcohol or drugs. Always drive your modified vehicle at reduced speeds to ensure your ability to control your vehicle under all driving conditions. Always wear your seat belt.

BEFORE INSTALLATION

Special literature required: OE Service Manual for model/year of vehicle. Refer to manual for proper disassembly/reassembly procedures of OE and related components.

Adhere to recommendations when replacement fasteners, retainers and keepers are called out in the OE manual.

Larger rim and tire combinations may increase leverage on suspension, steering, and related components. When selecting combinations larger than OE, consider the additional stress you could be inducing on the OE and related components.

Post suspension system vehicles may experience drive line vibrations. Angles may require tuning, slider on shaft may require replacement, shafts may need to be lengthened or trued, and U-joints may need to be replaced.

Secure and properly block vehicle prior to installation of BDS Suspension components. Always wear safety glasses when using power tools.

If installation is to be performed without a hoist, BDS Suspension Co. recommends rear alterations first.

Due to payload options and initial ride height variances, the amount of lift is a base figure. Final ride height dimensions may vary in accordance to original vehicle attitude. Always measure the attitude prior to beginning installation.

BEFORE YOU DRIVE

Check all fasteners for proper torque. Check to ensure for adequate clearance between all rotating, mobile, fixed, and heated members. Verify clearance between exhaust and brake lines, fuel lines, fuel tank, floor boards and wiring harness. Check steering gear for clearance. Test and inspect brake system.

Perform steering sweep to ensure front brake hoses have adequate slack and do not contact any rotating, mobile or heated members. Inspect rear brake hoses at full extension for adequate slack. Failure to perform hose check/ replacement may result in component failure. Longer replacement hoses, if needed can be purchased from a local parts supplier.

Perform head light check and adjustment.

Re-torque all fasteners after 500 miles. Always inspect fasteners and components during routine servicing.

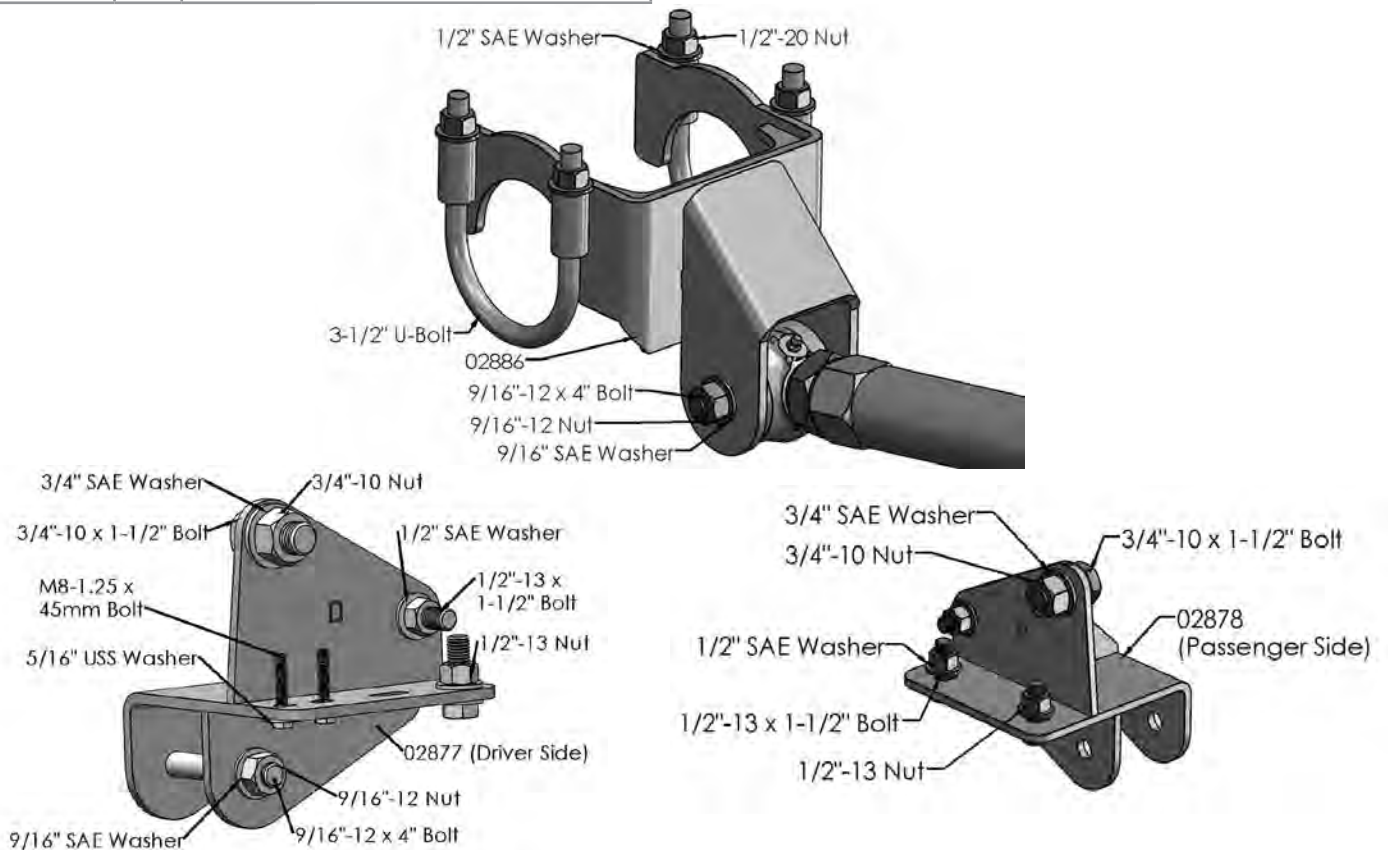
CONTENTS OF YOUR KIT

Box Kit 123408

Part #	Qty	Description
02877	1	Frame Bracket - DRV
02878	1	Frame Bracket - PASS
02886	2	Axle Bracket
123120512RB	4	1/2" x 3-1/2" x 5-1/4" Round U-bolt
02910	2	Jam Nut Wrench
B1153	1	Bag Kit
099002	2	Mountable Zip Tie
961	1	Bolt Pack (Frame Mounts)
	2	3/4"-10 X 1-1/2" Bolt - Grade 8
	4	3/4" SAE Washer
	2	3/4"-10 Prevailing Torque Nut
	5	1/2"-13 x 1-1/2" Bolt - Grade 8
	10	1/2" SAE Washer
	5	1/2"-13 Prevailing Torque Nut
	2	8mm-1.25 X 45mm Bolt - Class 10.9
	2	5/16" USS Washer
964	1	Bolt Pack (Traction Bar Hardware)
	4	9/16"-12 x 4" Bolt - Grade 8
	4	9/16"-12 Prevailing Torque Nut
	8	9/16" SAE Washer
962	1	Bolt Pack (Axle Mount)
	8	1/2"-20 Prevailing Torque Nut
	8	1/2" SAE Washer

Box Kit 123409

Part #	Qty	Description
A255	2	Traction Bar Assembly
02865	1	Traction Bar
02866	1	Spacer Washer
02867	1	Bushing
02868	1	Guide Bolt
02869	1	Traction Bar Slider End
033001	1	Heavy Rate Spring
033002	1	Lite Rate Spring
9452K63	2	O-Ring
91985A231	1	Internal Retaining Ring
3537BK	2	Bushings
61	1	Sleeve
516	2	Grease Fitting
A171	1	Forged Flex Joint End





INSTALLATION INSTRUCTIONS

AXLE BRACKET INSTALLATION

1. Park the vehicle on a clean, flat surface and block the rear wheels for safety.

! Caution *This installation should be done with the weight of the vehicle on the rear axle.*

2. Starting on the driver side of the vehicle, locate the axle mount bracket (02886). The axle mount will be mounted in front of the leaf spring perch, with the mount facing towards the front of the vehicle. *Note: The brackets are designed to work with the factory style square U-bolts running from the top down and round U-bolts running from the bottom up.*
3. Depending upon which lift block is installed in the rear, the U-bolts and lift block may need to be temporarily removed to install the axle bracket due to clearance to the bump stop wing during installation. The factory 2" rear block will require the lift block to be removed for axle mount bracket installation. See steps 4-9 for lift block removal and installation.
4. To remove the lift block, raise the rear of the vehicle and support with jack stands under the frame rails just ahead of the spring hangers.
5. Support the axle with a hydraulic jack.
6. Remove the 4 nuts from the U-bolts and lower the axle.
7. Remove the lift block and install the axle mount bracket in front of the leaf spring mount on the axle.
8. After the axle mount bracket is installed, reinstall the lift block with the bump stop wing positioned inboard and ensuring the alignment pins in the block, leaf spring, and axle all line up. Loosely tighten the U-bolts and lower the vehicle to the ground.
9. With the weight of the vehicle on the axle, torque the U-bolts to 75 ft-lbs.

FIGURE 1

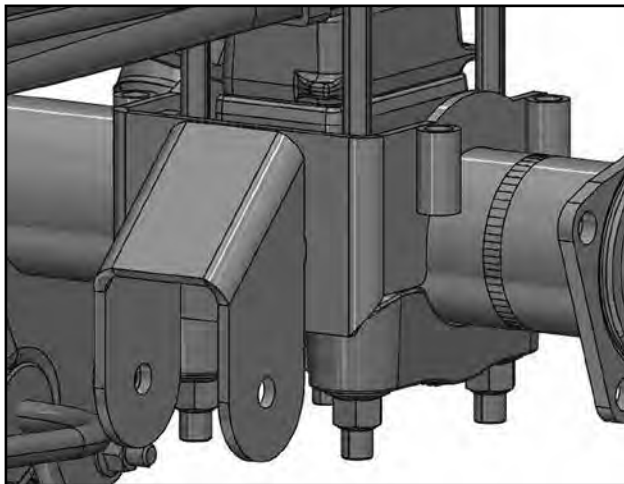
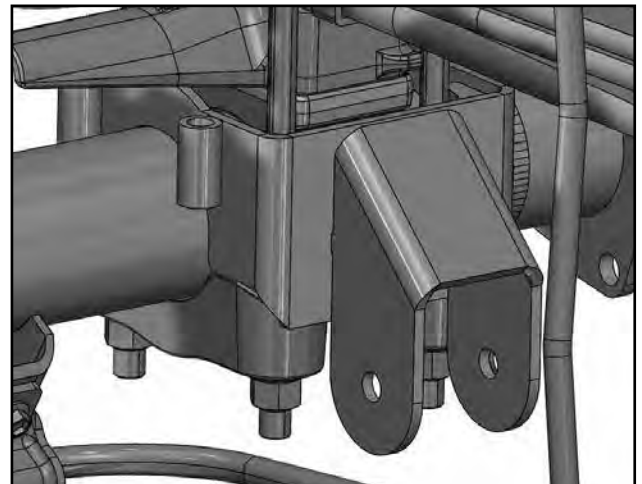
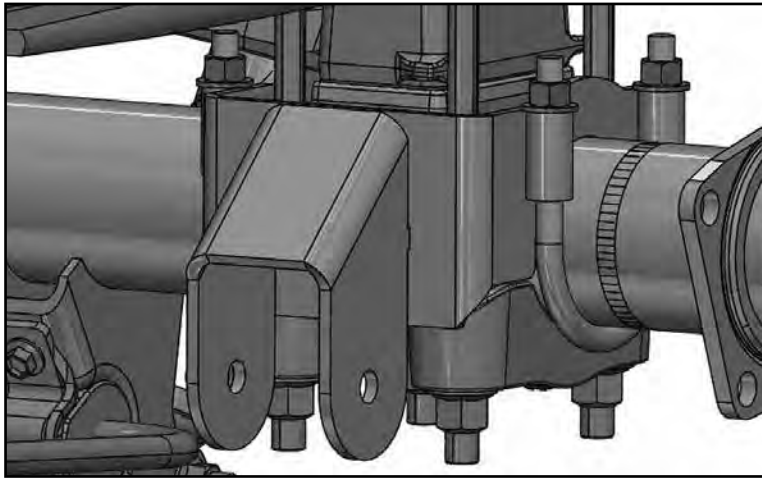


FIGURE 2



10. Locate two of the 1/2" U-bolt and install around the axle and up through the sleeves in the axle mount bracket (02886). Using the 1/2" fine thread nut and 1/2" SAE washer from Bolt Pack 962, tighten the U-bolts so that the axle mount clamps around the axle. The axle mount bracket should be parallel with the leaf spring perch. Tighten the 1/2" fine thread hardware to 45 ft-lbs.

FIGURE 3



11. Repeat axle bracket installation on the passenger's side of the vehicle.

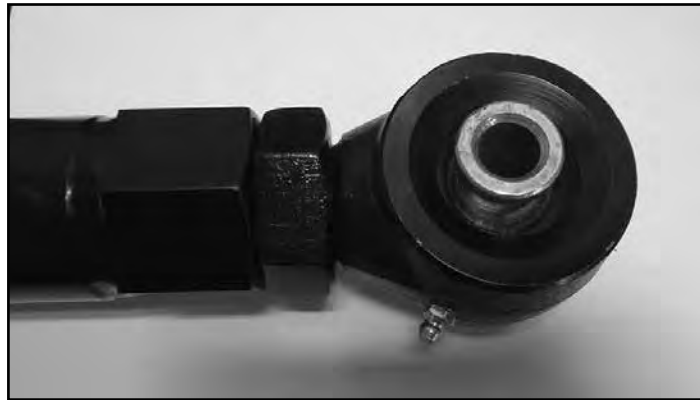


Tip *While this system was designed and tested as a "bolt-on" kit, the axle and frame bracket can also be tack welded to the vehicle. This would only be necessary if increased torque/leverage was consistently applied over the normal loads.*

TRACTION BAR INSTALLATION

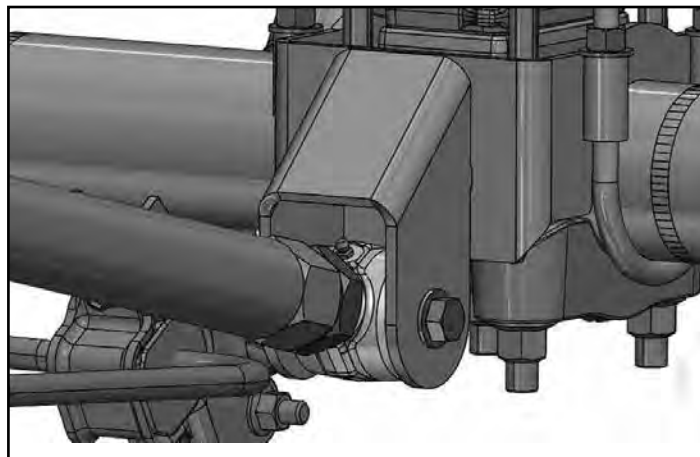
12. Check that the jam nut on the Forged Flex End (A171) is threaded in as far as it can go on the shaft of the Forged Flex End. Make sure the Forged Flex End is completely threaded into the Recoil Traction Bar (02865) up to the jam nut as shown in Figure 4.

FIGURE 4



13. Attach the Recoil Traction Bar to the axle bracket with a 9/16" x 4" bolt, 9/16" nut and 9/16" SAE washers from Bolt Pack 964. Install the Recoil Traction Bar so that the Forged Flex End (A171) is mounted to the axle bracket. Leave mounting hardware loose at this time

FIGURE 5



14. Measure the length of the bar from the center of the bolt at the axle to the center of the sleeve at the traction bar slider end (02869). The length should be approximately 59-3/4" +/- 0.25". If not, press firmly on the traction bar slider end to seat the springs.
15. Leave the bar resting on the ground at this time.

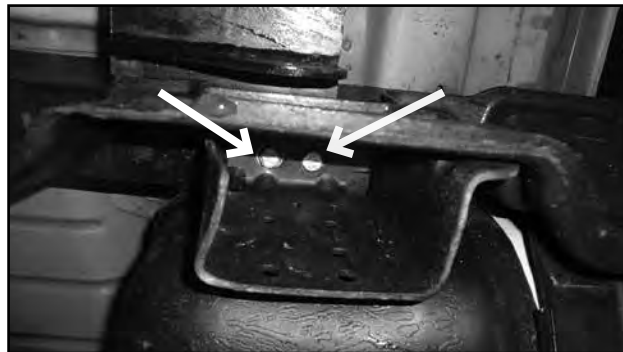
FRAME BRACKET INSTALLATION

16. **2011+ Models Only:** Starting on the driver's side, remove the two 8mm bolts from the front fuel tank shield support.

FIGURE 6



FIGURE 7

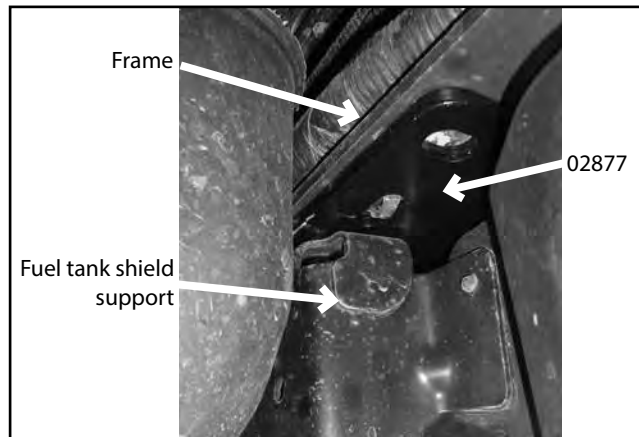


17. Install the driver's side frame mount bracket (02877) with the provided 3/4" x 1-1/2" bolt, 3/4" SAE washers, and 3/4" nut from Bolt Pack 961 through the hole on the bracket and into the slot on the frame. Leave hardware loose. **2011+ Models Only:** The bracket will be sandwiched in between the frame and fuel tank shield support as shown in Figure 9.

FIGURE 8

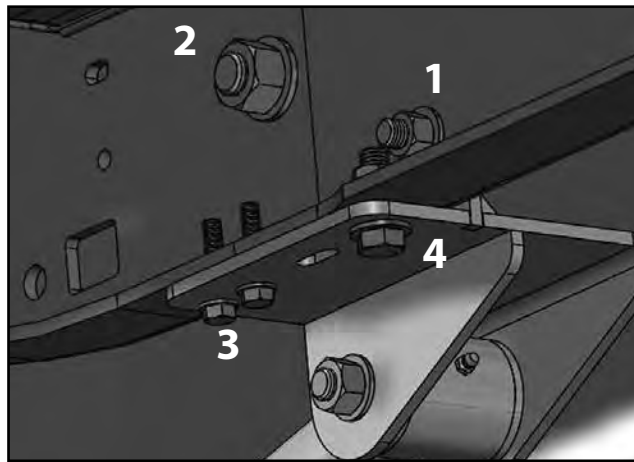


FIGURE 9



19. **2011+ Models Only:** Install the two provided 8mm x 45 mm bolts and 5/16" USS washers from Bolt Pack 961 through the two holes in the fuel tank shield support, sandwiching the frame mount bracket (02877) between the frame and fuel tank shield support. Leave hardware loose. *Note: Make sure the 8mm U-Nuts in the frame line up with the holes in the bracket and fuel tank shield support.*
20. Slide the frame bracket as far back towards the axle as it can go in the slots in the frame. Snug up the 8mm hardware at this time. Mark the location of the other two larger 9/16" holes on the frame. *Note: If the truck is not lifted in the rear and utilizes the factory rear block, slide the frame bracket as far forward as possible in the slot in the frame towards the front of the truck.*
21. **1999-2010 Models:** Mark the location of the two smaller slotted holes that are side by side (not the long slotted hole) on the bottom side of the frame. (Reference Figure 10 for which holes to mark)
22. Remove the bracket and drill both larger holes out to 9/16". **1999-2010 Models:** Drill both smaller slotted holes out to 3/8". (Reference Figure 10 for which holes to drill)
23. Loosely attach the frame mount with the 8mm and 3/4" hardware. Loosely install a 1/2" x 1-1/2" bolt, SAE washer, and 1/2" nut from Bolt Pack 961 through each of the holes drilled in the frame from the previous step and frame bracket (02877).
24. Tighten the bracket hardware in this sequence: the outer 1/2" hardware to 65 ft-lbs, then the 3/4" hardware to 200 ft-lbs, the two 8mm bolts to 25 ft-lbs, and last the 1/2" hardware through the bottom of the frame rail to 65 ft-lbs. See Figure 10.

FIGURE 10



25. Attach the traction bar slider end (02869) to the frame bracket using a 9/16" x 4" bolt, 9/16" nut and 9/16" SAE washers from Bolt Pack 964. *Note: The traction bar slider end will slide out of the Recoil Traction Bar to attach to the frame mount. If it cannot slide out far enough, spin the bar so that it unthreads from the Forged Flex End.*

FIGURE 11



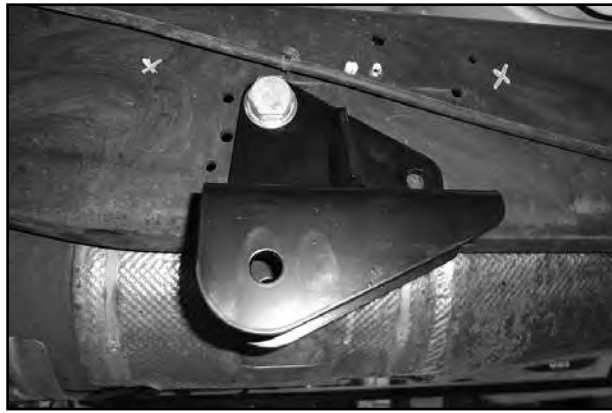
26. Repeat installation on the driver side using the passenger's side frame mount bracket (02878). Some models have a wire harness on the passenger side. First unclip the wire harness from the frame near the slot to gain slack. See Figure 12.

FIGURE 12



27. Install the 3/4" x 1-1/2" bolt, 3/4" SAE washers, and 3/4" nut through the hole on the bracket and into the slot in the frame.

FIGURE 13



- 28. 1999-2010 Models Only:** Some Models require the exhaust hanger bracket to be flipped on the passenger side. Locate the 3/4" slotted hole on the frame and the two M10 studs near the slot. Using a 13mm socket, remove the two nuts. Rotate the exhaust hanger 180 degrees so that it is up side down to how it was installed from the factory. The M10 studs will line up with two other holes in the frame above the previous holes. Insert the studs into these two holes and tighten down with the factory hardware. Figure 16 shows the stock mounting location and Figure 17 shows the flipped mounting location. *Note: The exhaust hanger mount may need to be bent down to line up with the holes in the frame and attached to the rubber isolator, see next step for how to bend down the exhaust hanger.*

FIGURE 14

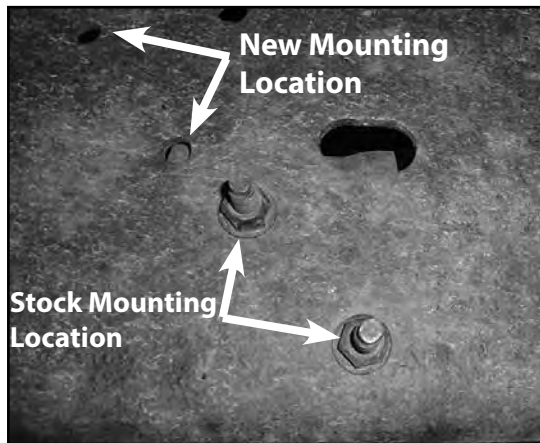


FIGURE 15



FIGURE 16



FIGURE 17



- 30. 1999-2010 Models Only (Exhaust Hanger Modification):** Rotate the exhaust hanger down and remove the hanger from the rubber isolator. Using a vice and a hammer, bend the hanger so that it becomes flatter, pointing more towards the ground when installed up side down. The hanger and mounting plate should form approximately a 110 degree angle. *Note: Do not bend the hanger too far such that it will not support the exhaust.*

FIGURE 18

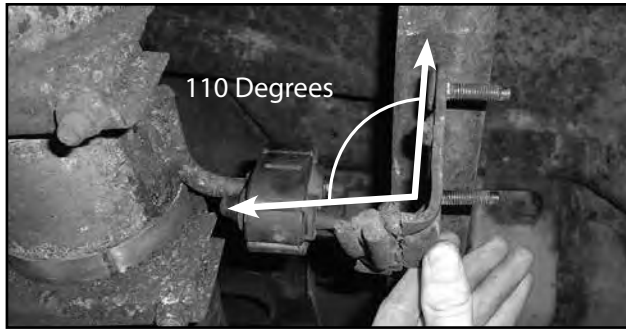
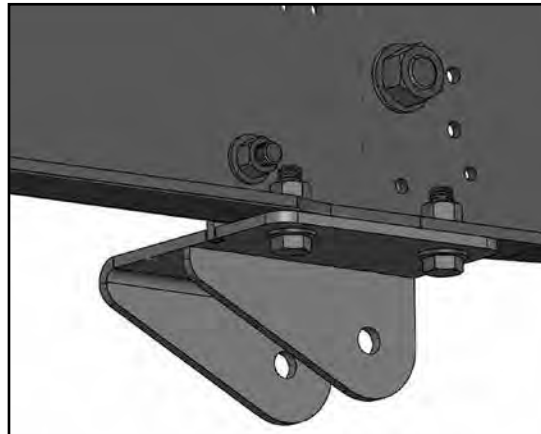


FIGURE 19



32. Slide the frame bracket as far back towards the axle as it can go in the slots in the frame. Mark the location of the three holes on the frame. *Note: If the truck is not lifted in the rear and utilizes the factory rear block, slide the frame bracket as far forward as possible in the slot in the frame towards the front of the truck.*
33. Remove the bracket and drill the three holes out to 9/16".
34. Loosely attach the frame mount with the 3/4" hardware. Loosely install a provided 1/2" x 1-1/2" bolt, 1/2" SAE washer, and 1/2" nut through each of the holes drilled in the frame from the previous step and frame bracket (02878).
35. Tighten the three 1/2" bolts to 65 ft-lbs, and the 3/4" bolt to 200 ft-lbs.

FIGURE 20



36. Models with a wire harness on the passenger side will use the provided mountable zip ties (tree on the end) to route the wire harness above the passenger side bracket. Mark two locations to drill a 7/32" hole to attach the mountable zip ties that will hold the wire harness above the bracket. See Figure 21 for a guideline as to where to drill the holes.

FIGURE 21



37. Attach the traction bar slider end (02869) to the frame bracket using a 9/16" x 4" bolt, 9/16" nut and 9/16" SAE washers. The traction bar slider end should slide out of the Recoil Traction Bar to attach to the frame mount. Tighten the 9/16" hardware for the Recoil Traction Bars to 90 ft-lbs at both ends.
38. Grease all bushings and the Recoil Traction Bar before use. Do not over grease the Recoil Traction Bar, it is recommended to grease the Recoil Traction Bar one pump of grease every 10,000 miles.
39. Check all hardware for proper torque.

40. Check hardware after 500 miles.

TRACTION BAR ADJUSTMENT

41. Loosen the jam nut at the axle end with the two provided wrenches. Utilize a 1/2" ratchet or breaker bar in the wrench if needed.

FIGURE 22



42. Use the levels on the wrench to gauge how much force is inputted into the Recoil Traction Bar. The wrench is designed to be used at the traction bar slider end as shown in Figure 23. Make sure the wrench is pressed firmly against the bushing / tube for an accurate measurement.

FIGURE 23

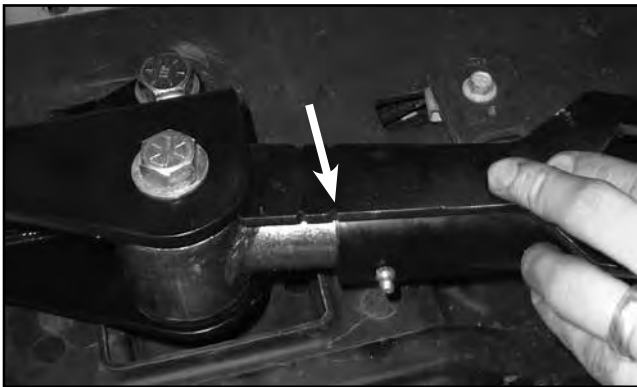
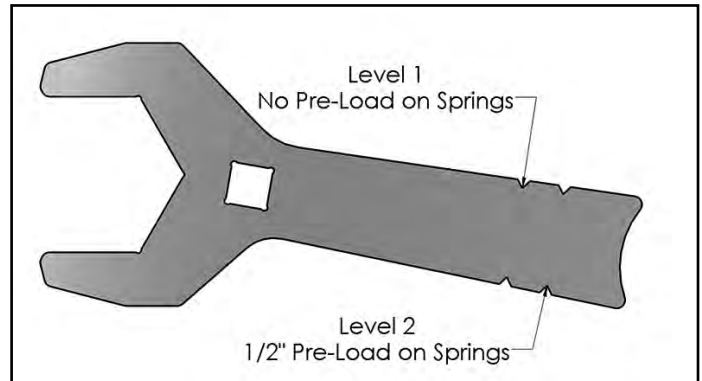
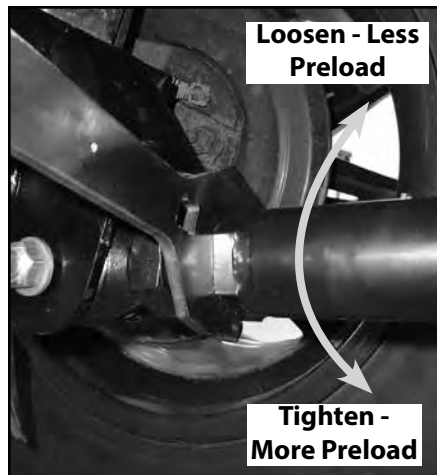


FIGURE 24



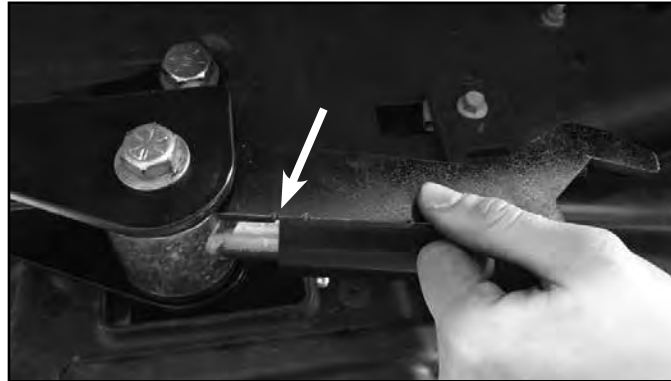
43. Utilizing the Levels on the wrench, spin the Recoil Traction Bar either clockwise to add more force into the dual coil springs setup to reduce axle wrap, or loosen the Recoil Traction Bar by spinning it counter clockwise in order to reduce the input the Recoil Traction Bar has on the suspension system. *Note: Depending upon lift height, the Recoil Traction Bar may need to unthreaded from the Forged Flex End until the First Level is reached on the wrench. At this point the dual coil spring setup are in contact and there is no preload in the springs.*

FIGURE 25



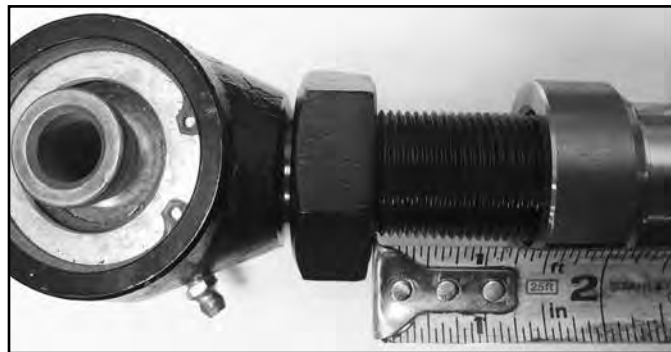
44. It is recommended when pulling or hauling heavy weights that Recoil Traction Bar be set at a minimum of the Second Level on the Jam Nut Wrench to help reduce axle wrap. The Second Level is 25% of the maximum force the springs output. The maximum amount of force that can be preloaded in the spring is 12 full rotations of the Recoil Traction Bar when starting at the First Level. This equals 1" of total preload in the dual coil spring setup in the Recoil Traction Bar. At this point, the dual coil spring setup creates a solid link between the frame and axle when in compression. DO NOT tighten the Recoil Traction Bar past this amount

FIGURE 26



45. Utilize the Jam Nut Wrench to set a desired force setting (Minimum of the First Level). Depending upon suspension setups, different spring preload may need to be tried to find a good setup to reduce axle wrap. After the desired force is set, lock off the jam nut with the two provided Jam Nut Wrenches and repeat this process on the other Recoil Traction Bar. *Note: Never unthread the forged flex end past 1-1/2" of adjustment. This can cause thread damage and weaken the joint. See Figure 27.*

FIGURE 27



46. The dual coil spring setup is utilized to always create contact between both ends of the Recoil Traction Bar. Having dual coil spring setup allows the Recoil Traction Bar system to not affect suspension performance at a lower force as seen at the First Level, allowing greater articulation and less affect on the suspension system. As the Recoil Traction Bar is adjusted and the dual coil spring setup are compressed, a higher force is exerted on the axle in order to reduce axle wrap. Each Level below corresponds to the levels on the wrench, representing different amounts of force in the Recoil Traction Bar system. *Note: It is recommended to never fully compress the spring past the 1" of compression. This can be measured 1" from the First Level on the Jam Nut Wrench.*

FIGURE 28

