



Installation Instructions HighRock 4x4™ Element Front Doors

Vehicle Application:
Jeep® Wrangler JL 2&4-Door 2018 and up
Part Number 51740-01

Installation Tips









Before you install your new High Rock 4x4™ Element Doors, please read all the instructions thoroughly.

! WARNING This product is designed primarily to enhance the appearance of the vehicle and to shield the occupants from ordinary weather conditions. Do not rely in any way on the components of this product to protect against injury or death in the event of an accident. Never operate the vehicle in excess of manufacturer’s specifications.

Read and follow, precisely, all installation instructions provided when installing this product. Failure to do so may result in a poor fit and could place occupants of the vehicle in a potentially dangerous situation.



WEAR SEAT BELTS AT ALL TIMES

Tools			Installation Time	
 Safety Glasses	 Ratchet	 T40 - T45 -T50 Torx Drivers		30 Minutes
 T20 -T30 Torx Drivers	 10mm Wrench	 4mm - 5mm Allen Wrenches		
			Skill Level	
				
			1 - Easy	



Installation Instructions HighRock 4x4™ Element Front Doors

Vehicle Application:
Jeep® Wrangler JL 2&4-Door 2018 and up
Part Number 51740-01

Parts List

- Required parts for installation - Page number in Installation Guide

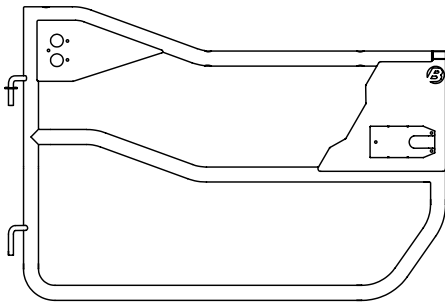
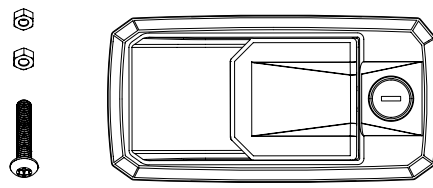
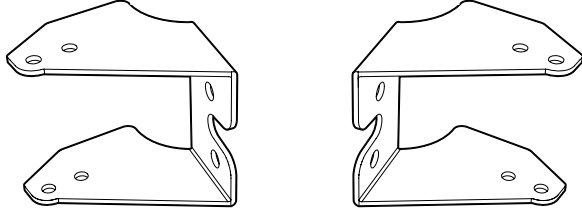
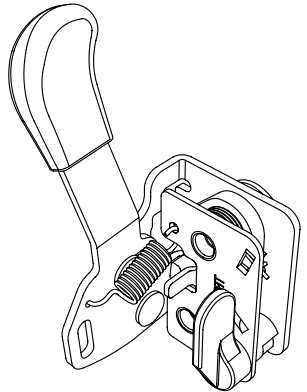
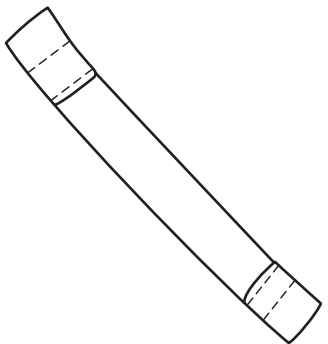
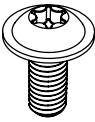
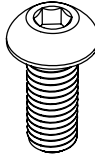
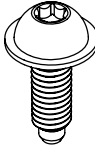
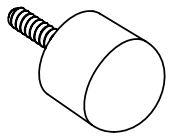
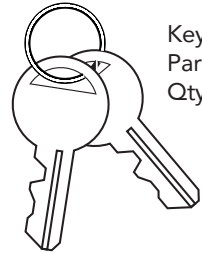
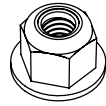
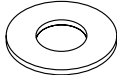
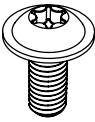
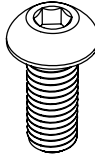
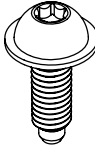
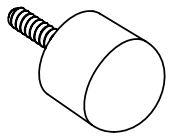
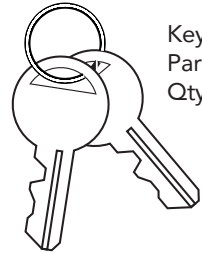
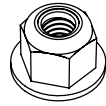
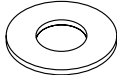
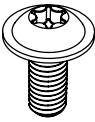
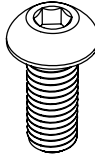
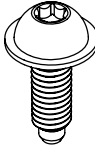
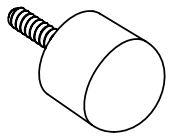
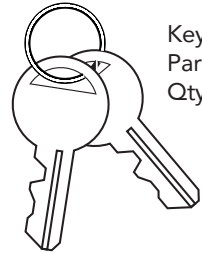
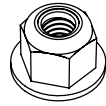
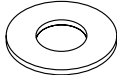
All Sections	Element™ Door Parts		Multiple Pages									
 <p>Door Frames Left (shown) Part #584.55 (matte finish) Right #584.54 (matte finish) Qty. 1 of each</p>	 <p>Locking Paddle Latch with Adjustment Screw and Jam Nuts (2) Part #584.61 Qty. 2</p>	 <p>Rotor Brackets Part #584.57 - Left Part #584.56 - Right Qty. 1 of each</p>										
 <p>Rotor Assembly Part #584.45 - Left Part #584.44 - Right (shown) Qty. 1 of each</p>	 <p>Door Restraint Part #428.59 Qty. 2</p>	<p>Small Parts Kit #577.71</p> <table border="0"> <tr> <td data-bbox="871 1015 1207 1144">  M5x0.8x12 Button Head Screw Part #531.49 Qty. 6</td> <td data-bbox="1249 1015 1585 1144">  M8x1.25x20 Button Head Screw Part #431.59 Qty. 4</td> <td data-bbox="1627 1015 1984 1169">  M6x1.0x15 Flanged Button Head Screw Part #533.61 Qty. 8</td> </tr> <tr> <td data-bbox="913 1218 1081 1453">  Bumper Part #585.04 Qty. 2</td> <td data-bbox="1165 1226 1459 1477">  Key Part #564.19 Qty. 2</td> <td data-bbox="1627 1218 1900 1331">  M6x1.0 Flanged Nut Part #515.82 Qty. 8</td> </tr> <tr> <td colspan="2"></td> <td data-bbox="1617 1380 1932 1469">  M8 Flat Washer Part #515.84 Qty. 4</td> </tr> </table>		 M5x0.8x12 Button Head Screw Part #531.49 Qty. 6	 M8x1.25x20 Button Head Screw Part #431.59 Qty. 4	 M6x1.0x15 Flanged Button Head Screw Part #533.61 Qty. 8	 Bumper Part #585.04 Qty. 2	 Key Part #564.19 Qty. 2	 M6x1.0 Flanged Nut Part #515.82 Qty. 8			 M8 Flat Washer Part #515.84 Qty. 4
 M5x0.8x12 Button Head Screw Part #531.49 Qty. 6	 M8x1.25x20 Button Head Screw Part #431.59 Qty. 4	 M6x1.0x15 Flanged Button Head Screw Part #533.61 Qty. 8										
 Bumper Part #585.04 Qty. 2	 Key Part #564.19 Qty. 2	 M6x1.0 Flanged Nut Part #515.82 Qty. 8										
		 M8 Flat Washer Part #515.84 Qty. 4										

Section 1 Remove and Store Hinge Screws

Step 1

Tools



Ratchet



T50
Torx Driver

Step 2

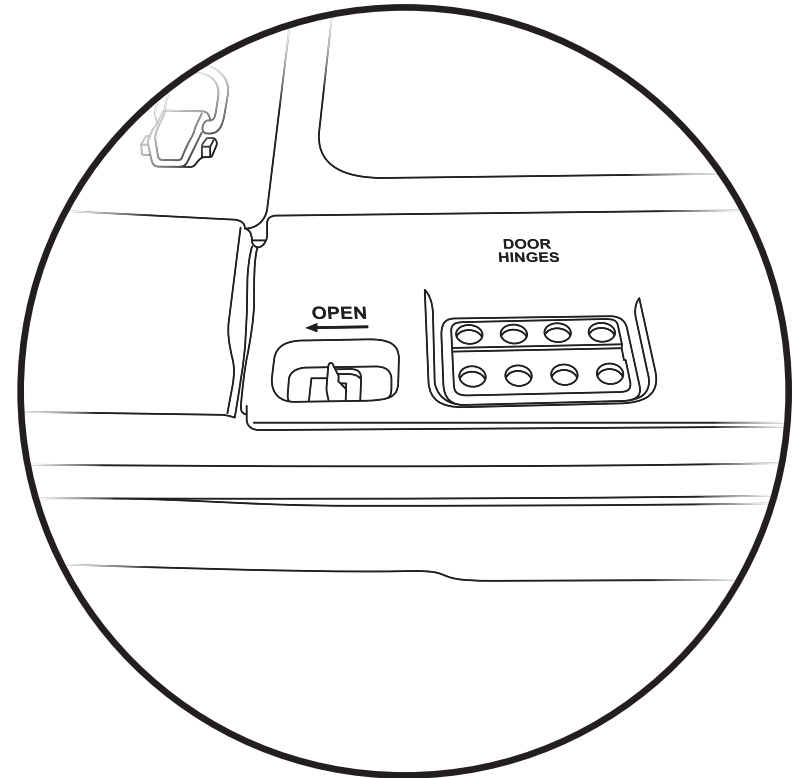
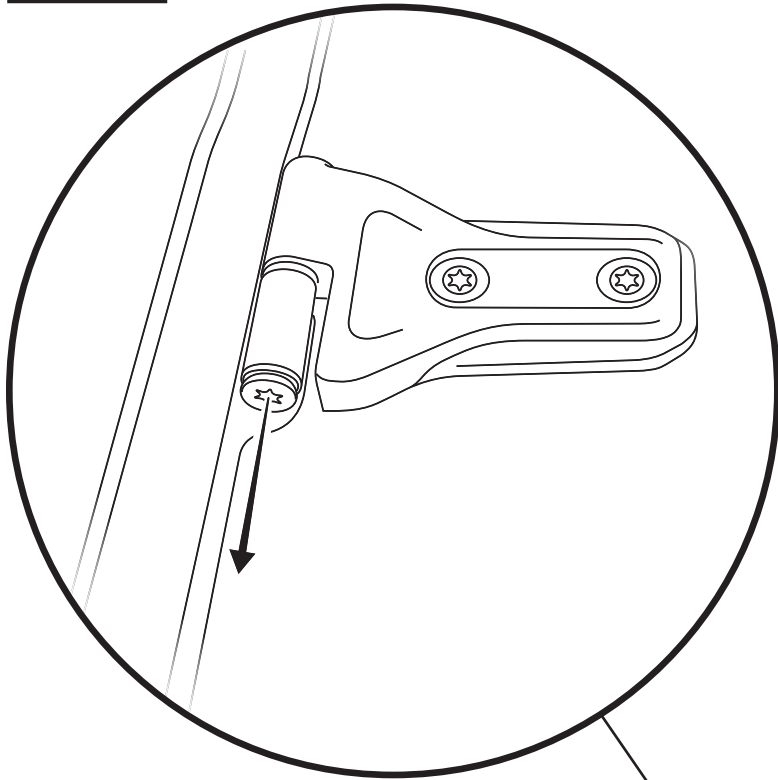

Step 1

Using a T50 Torx bit, remove the Hinge Screws from the bottom of each door hinge - 2-door or 4-door.

Step 2

Store the Door Hinge Screws underneath the hinged floor cover at the rear of the Jeep.

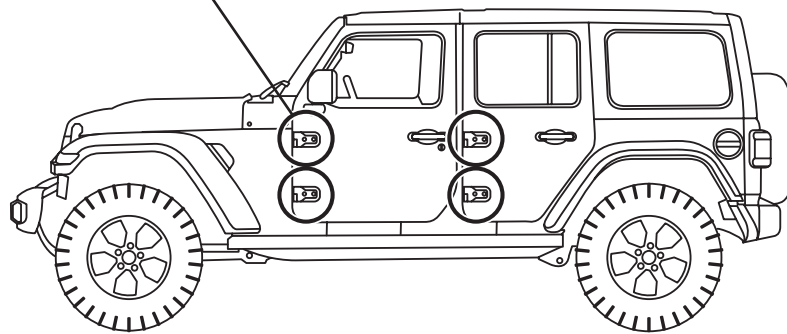

Section 2 Release Door Linkages; Release Door Retention Straps

Step 1

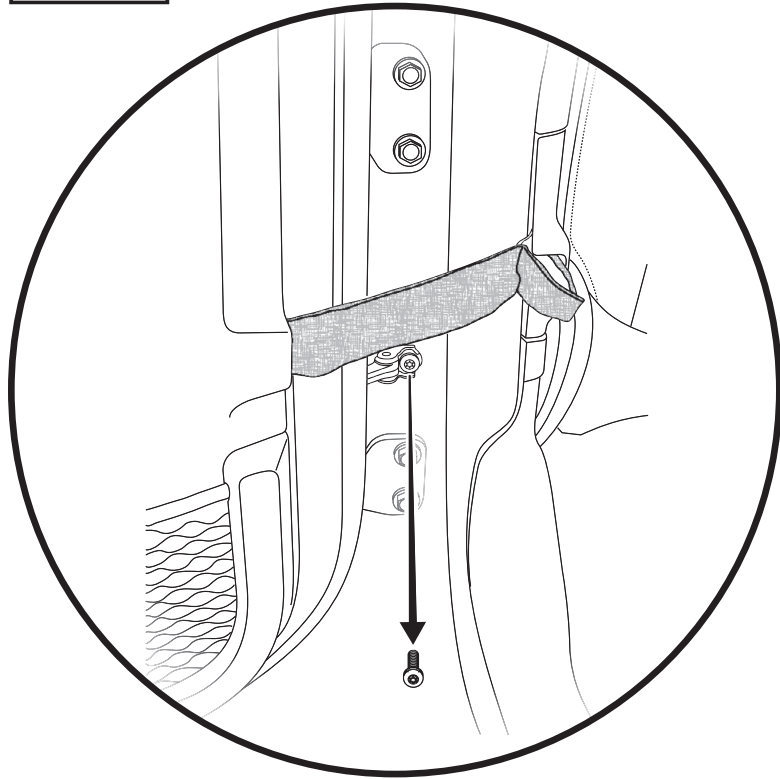

Tools



Ratchet



T40
Torx Driver

Step 2

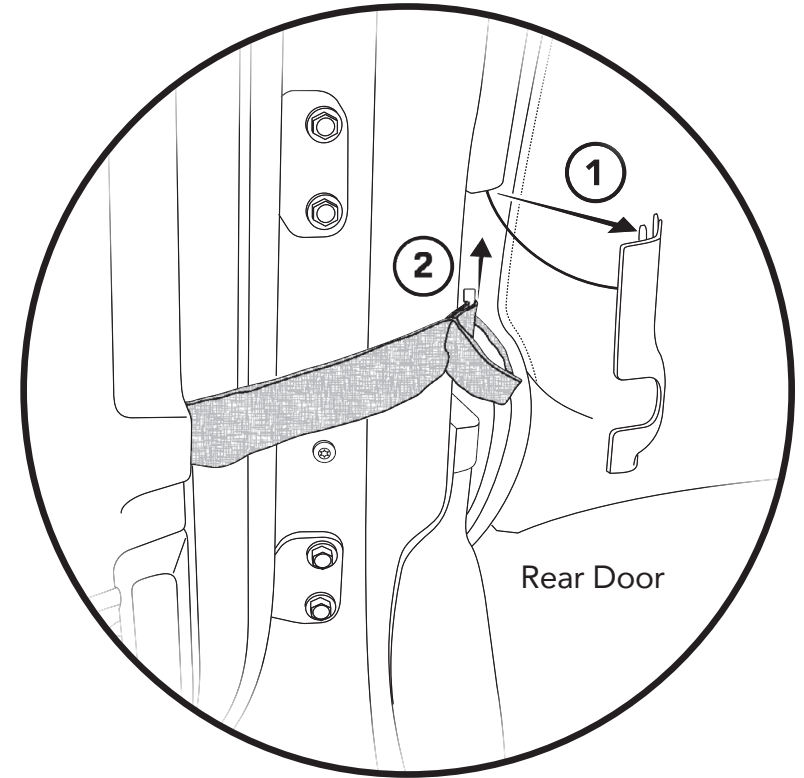

Step 1

Using a T40 Torx bit, remove the door linkage screw on the inside of the door frame.

Move the door linkage aside and replace the screw.

Do this on each door that you are removing, on both 2 and 4-door Jeeps.

Step 2

Rear Door:

- ① Remove the tethered plastic cover over the Door Retention Strap Hook.
- ② Remove the loop end of the Door Retention Strap from the Hook. Lift the loop up and off of the metal hook.

Section 3 Unplug Connectors; Lift Doors Off Hinges

Step 1

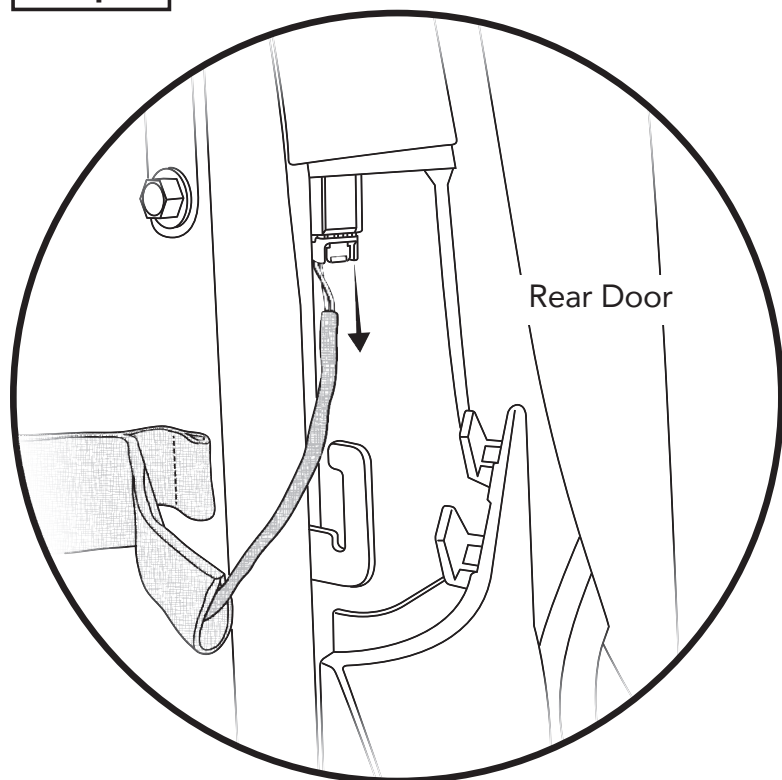

Step 1

Rear Door:

With the tethered plastic cover removed, unplug the connector behind the cover, and at the end of the wrapped wire bundle that is inside of the door restraint strap.

Replace the plastic cover after you have unplugged the connector.

You may now lift this door off the hinge.

Step 2

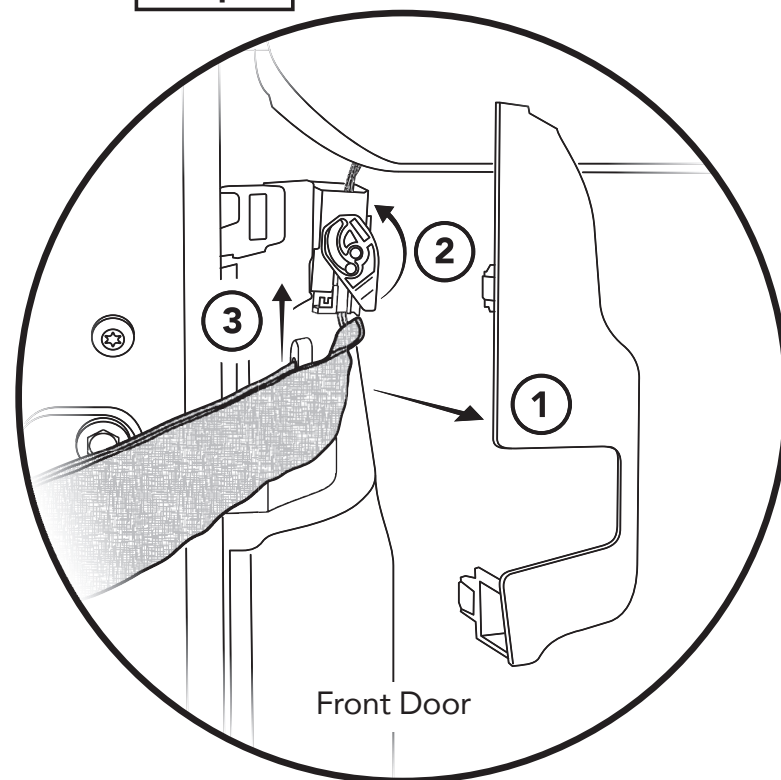

Step 2

Front Door:

① Remove the tethered plastic cover over the Door Retention Strap Hook.

② Slide the red latch on the connector up, and pivot the white receptacle lock 180°, and remove the connector.

③ Remove the loop end of the Door Retention Strap from the Hook. Lift the loop up and off of the metal hook.

You may now lift this door off the hinge.

Section 4 Install Paddle Adjustment Screw

Step 1 584.61

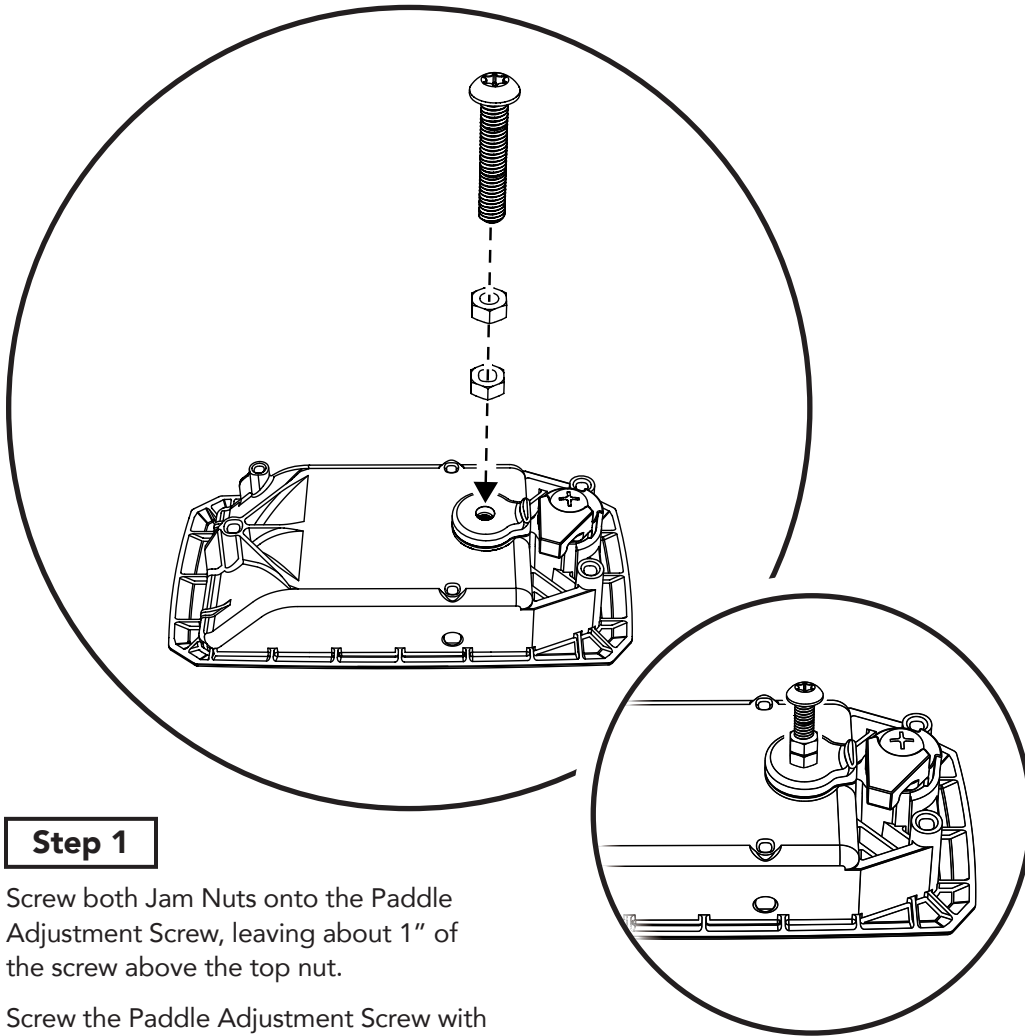

Step 1

Screw both Jam Nuts onto the Paddle Adjustment Screw, leaving about 1" of the screw above the top nut.

Screw the Paddle Adjustment Screw with the Jam Nuts into the back side of the Paddle, in the location shown.

Screw the Adjustment Screw and Jam Nuts into the Paddle until the bottom Jam Nut contacts the back of the Paddle.

Hardware

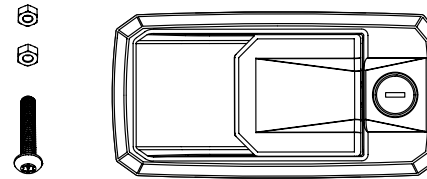

Locking Paddle Latch with
Adjustment Screw and Jam Nuts (2)
Part #584.61
Qty. 2

Tools



4mm
Allen Wrench

10mm Wrench

Section 5 Install Paddle Latches

Step 1 531.49

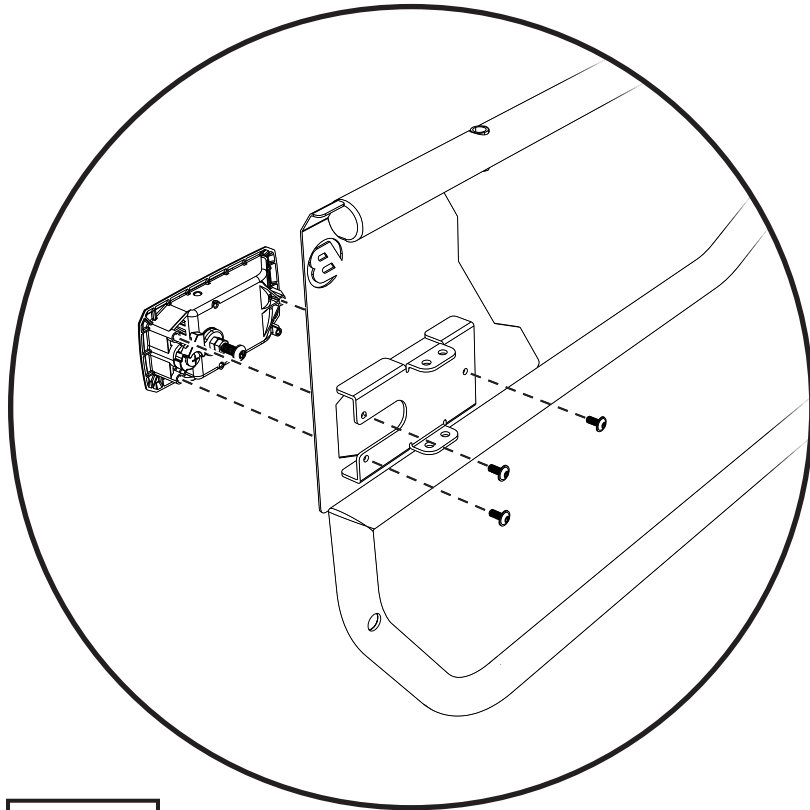

Hardware

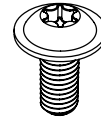

M5x0.8x12
Button Head Screw
Part #531.49
Qty. 6

Tools

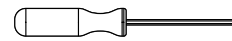

T20 Torx
Driver

Step 1

Attach the Paddle Handle assemblies to the Element Doors.

Insert each Paddle Handle assembly into the pocket in the Element Door.

Make sure that the lock on the Paddle is toward the rear of the door.

Secure the Paddle Latches to the Element Doors using three (3) M5x0.8x12 Button Head Screws #531.49 on each latch.

Section 6 Install Rotor Brackets

Step 1	584.56	584.57	533.61	515.82
---------------	--------	--------	--------	--------

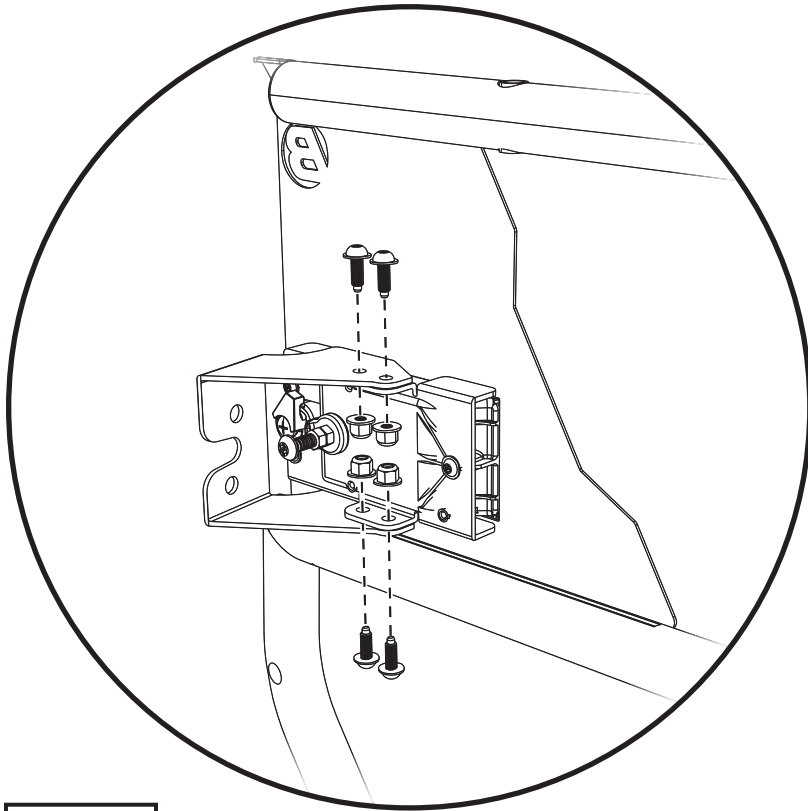

Step 1

Attach the Rotor Brackets to the rear of the Paddle Latch pockets in each door.

Attach the left Rotor Bracket #584.57 to the left side Element Door using four (4) M6x1.0x15 Flanged Button Head Screws #533.61 with M6x1.0 Flanged Nuts #515.82.

Note the position of the Rotor-mounting holes on the left Bracket shown in the illustration above.

Attach the right Rotor Bracket #584.56 to the right side Element Door using four (4) M6x1.0x15 Flanged Button Head Screws #533.61 with M6x1.0 Flanged Nuts #515.82.

Hardware

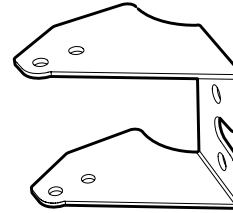

Rotor Brackets
Part #584.57 - Left
Part #584.56 - Right
Qty. 1 of each

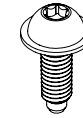

M6x1.0x15
Flanged Button Head
Screw
Part #533.61
Qty. 8



M6x1.0
Flanged Nut
Part #515.82
Qty. 8

Tools



T30 Torx
Driver



10mm Wrench

NOTE:

Leave these fasteners loose until after you have installed the Rotor Assembly (next page).

Section 7 Install Rotor Assemblies

Step 1

584.44

584.45

431.59

515.84

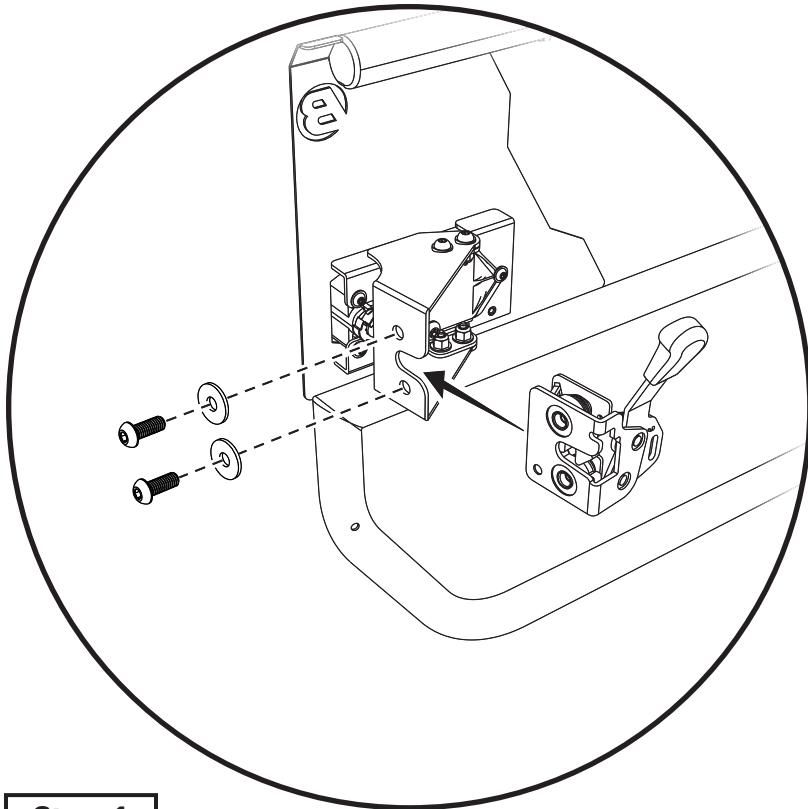

Step 1

Attach the Rotor Assemblies to the Rotor Brackets.

Attach the Left Rotor Assembly #584.45 to the left Rotor Bracket using two (2) M8 x 1.25 x 20 Button Head Screws #431.59 and two (2) M8 Flat Washers #515.84.

Attach the Right Rotor Assembly #584.44 to the right Rotor Bracket using two (2) M8 x 1.25 x 20 Button Head Screws #431.59 and two (2) M8 Flat Washers #515.84.

Make sure that Rotor Assembly and Paddle Assembly are aligned to each other when assembled.

Incorrectly-installed Rotor Assemblies will be crooked, and will run into the Rotor Brackets.

Hardware

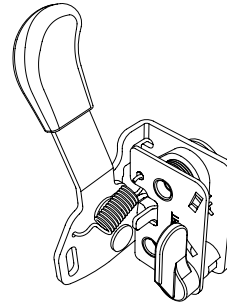

Rotor Assembly
Part #584.45 - Left
Part #584.44 - Right
Qty. 1 of each

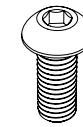

M8 x 1.25 x 20
Button Head Screw
Part #431.59
Qty. 4



M8 Flat Washer
Part #515.84
Qty. 4

Tools



5mm
Allen Wrench

NOTE:

Only tighten these fasteners and the fasteners from the previous installation step after you have actuated the lock mechanism, and made sure that there is clearance between the Rotors #584.44 and #584.45, and the Rotor Brackets #584.56 and #584.57.

Once there is proper clearance, with no interference, tighten all fasteners.

Section 8 Install Bumpers

Step 1 585.04

Hardware

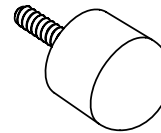

Bumper
Part #585.04
Qty. 2

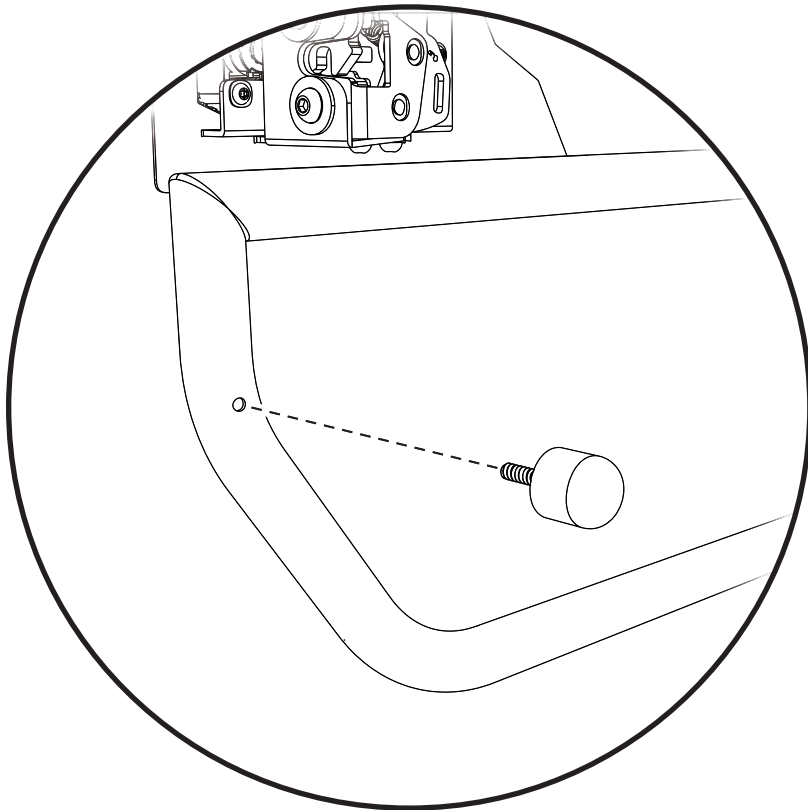

Step 1

Attach Bumpers to Element Doors.

Screw a Bumper #585.04 into the threaded hole in the lower rear inside portion of each Element Door.

Section 9 Attach Doors to Vehicle Hinges

Step 1

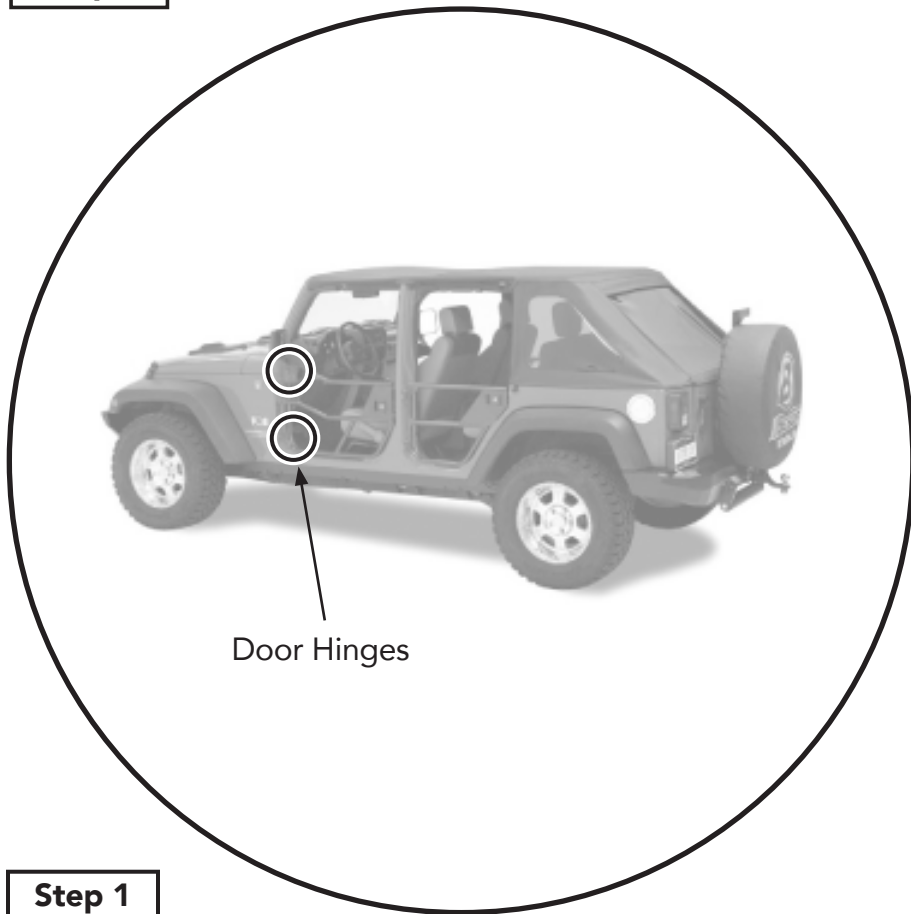

Detail

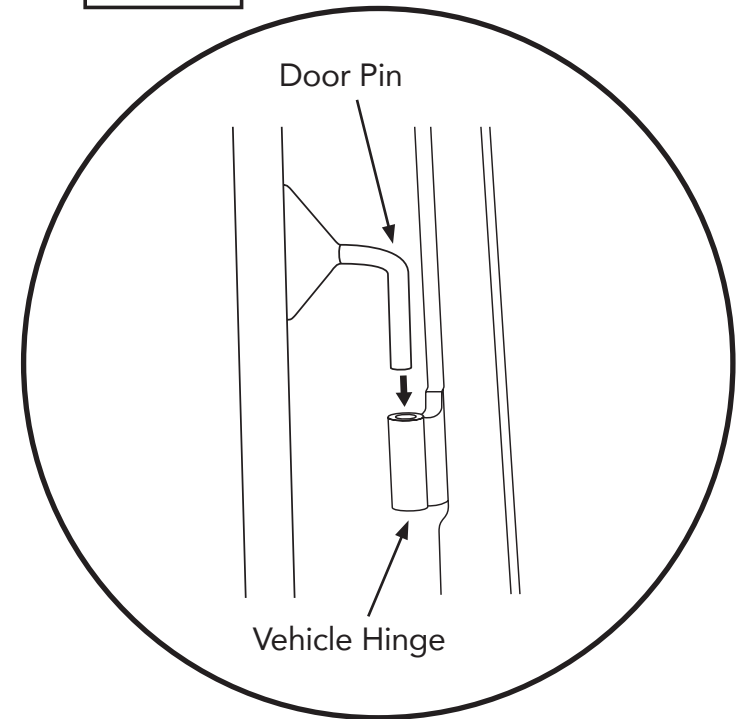

Step 1

Hold the door straight out from the vehicle with the hinge pins over the body hinges.

Lower the pins into the hinges.

Make sure that the pins are fully inserted into the body hinges.

See Detail.

Section 10 Install Door Restraint Straps

Step 1 428.59

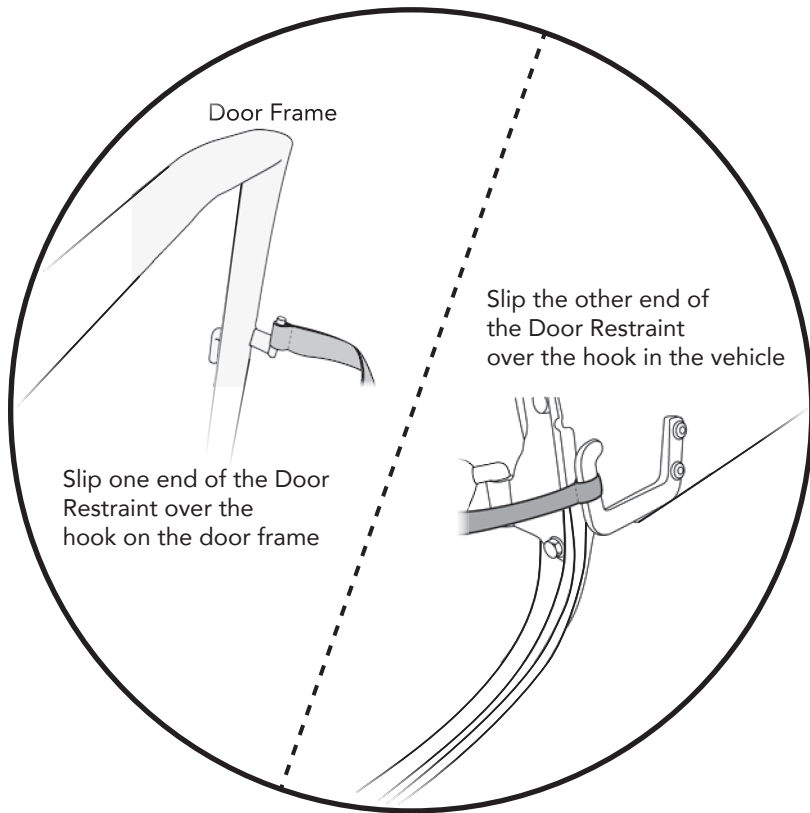

Hardware

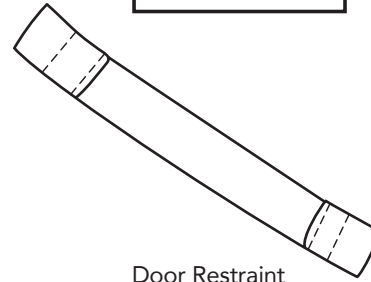

Door Restraint
Part #428.59
Qty. 2

Step 1

Locate the two (2) Door Restraints #428.59. Slip the loop in one end of a Door Restraint over the hook on the door frame.

Slip the loop in the other end of the Door Restraint over the hook on the vehicle body.

Repeat on both sides of the Jeep.

Section 11 Attach Original Mirrors; Adjust Paddles

Step 1

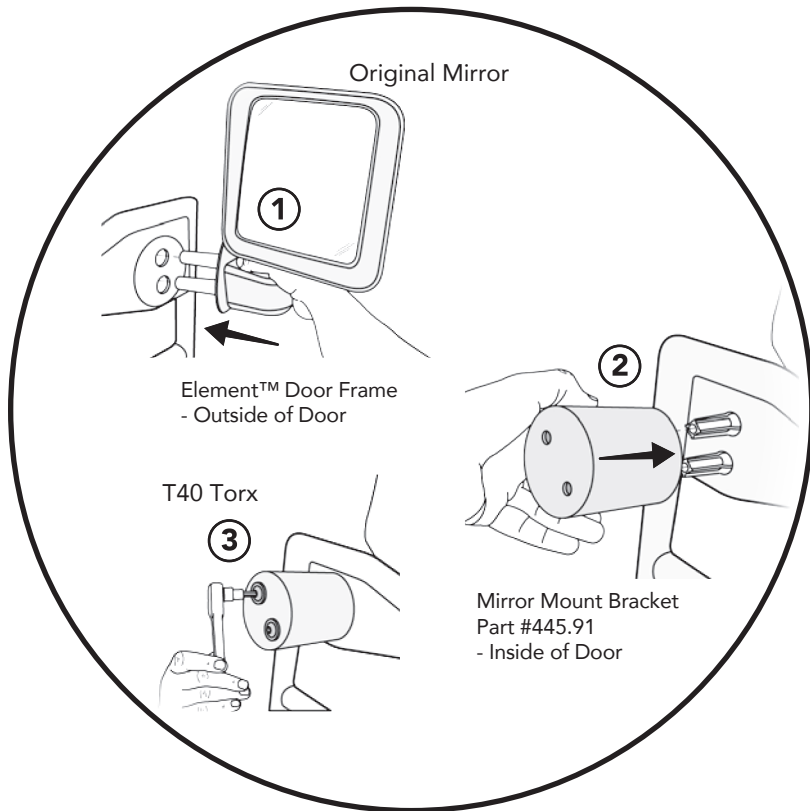

Tools



Ratchet



T40
Torx Driver

Step 2

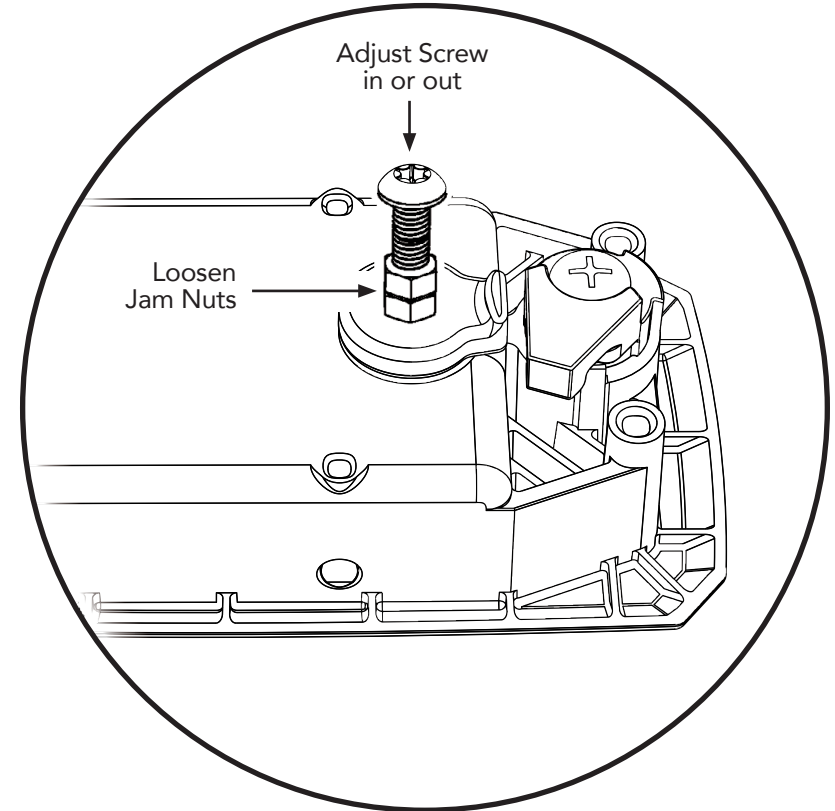

Step 1

The mirrors from the original doors can be mounted to the Element Doors using Mirror Mount Bracket Kit #5173401 (available separately from Bestop).

Use a T40 Torx wrench to remove the mirrors from the factory doors.

Align the holes in a Mirror Mount Bracket with the holes on the inside of the Element™ Door.

Slide the pins on the mirror through the door from the outside into the bracket. Secure using the two original mounting screws.

Step 2

The Paddle Latch mechanism can be adjusted using the Screw and Jam Nuts that you installed in Section 1, Page 4.

Loosen the Jam nuts to allow the Screw to be adjusted in or out, and then re-tighten the Jam Nuts to secure the Screw in place.