



Installation Instructions Supertop for Trucks

Vehicle Application:
Chevrolet Colorado & GMC Canyon 2015-Current 6' Bed
Part Number 77322-35

Installation Tips

Before you begin installing your new Supertop for Trucks, please read all the instructions thoroughly.

It is recommended that two people install this Bestop product.

For a smooth fit:

For easier installation, the top should be installed at a temperature above 72° F. Below this temperature, the fabric may contract an inch or more, making it difficult to fit the vehicle. You may let the fabric sit in the sun for 15-20 minutes before installing to let the fabric warm up.

It is normal for the fabric to contract and wrinkle when stored in the shipping carton. Within a few days after installation, the fabric will relax and the wrinkles will disappear.

WARNING Do not rely in any way on the components of this product to protect against injury or death in the event of an accident. Never operate the vehicle in excess of manufacturer's specifications.

Read and follow, precisely, all installation instructions provided when installing this product. Failure to do so may result in a poor fit and could place occupants of the vehicle in a potentially dangerous situation.

CAUTION Safety glasses should be worn at all times when installing this product.

WEAR SEAT BELTS AT ALL TIMES



Tools



Ratchet



9/16" Socket

- OR -



9/16" Wrench

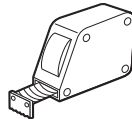

Tape Measure



Safety Glasses



1/8" Allen Wrench

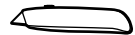

Utility Knife

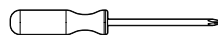

Phillips Screwdriver



Wire Ties
(Not included)

Installation Time



2 hours

Skill Level



3 - Moderately Difficult







Installation Instructions Supertop for Trucks

Vehicle Application:
Chevrolet Colorado & GMC Canyon 2015-Current 6' Bed
Part Number 77322-35

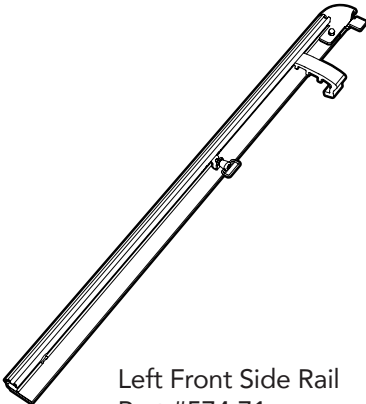
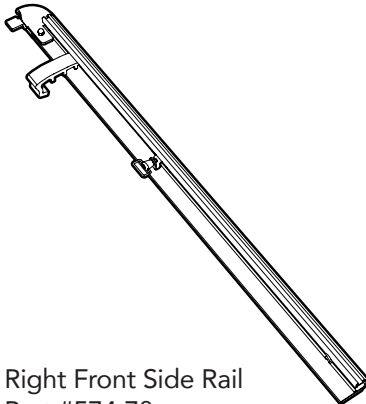
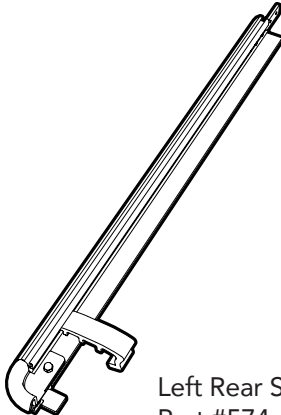
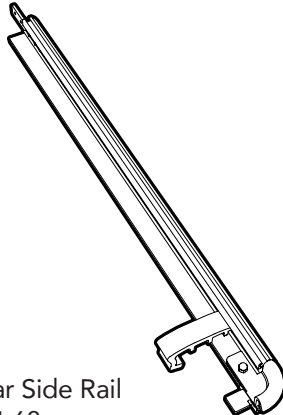
Parts List

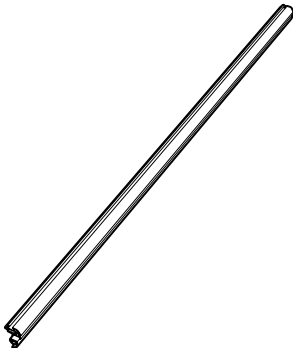
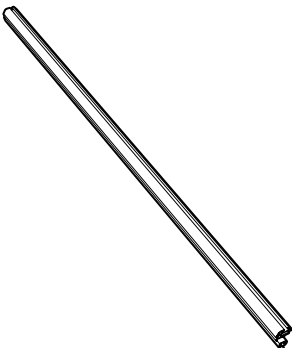
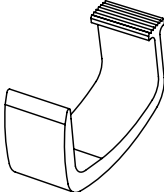
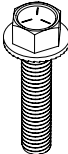
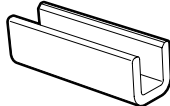
- Required parts for installation - Page number in Installation Guide

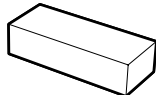
Sections 1 & 2		Side Rails						
 <p>Left Front Side Rail Part #574.71 Qty. 1</p>		 <p>Right Front Side Rail Part #574.70 Qty. 1</p>		 <p>Left Rear Side Rail Part #574.69 Qty. 1</p>		 <p>Right Rear Side Rail Part #574.68 Qty. 1</p>		
Sections 2 to 4		Hardware, Front and Rear Rails						
 <p>Screw Part #518.33 Qty. 2</p>	 <p>Set Screw Part #573.17 Qty. 4</p>	 <p>Front Rail Part #574.77 Qty. 1</p>		 <p>Rear Rail Part #574.78 Qty. 1</p>		 <p>Lower Clamp Part #579.23 Qty. 4</p>	 <p>Hex Head Bolt Part #578.39 Qty. 4</p>	 <p>Clamp Pad Part #577.39 Qty. 2</p>
 <p>Weld Nut Part #200.50 Qty. 2</p>	 <p>Flat Washer Part #436.16 Qty. 2</p>						 <p>Rubber Pad Part #720035 Qty. 4</p>	







Installation Instructions Supertop for Trucks

Vehicle Application:
Chevrolet Colorado & GMC Canyon 2015-Current 6' Bed
Part Number 77322-35

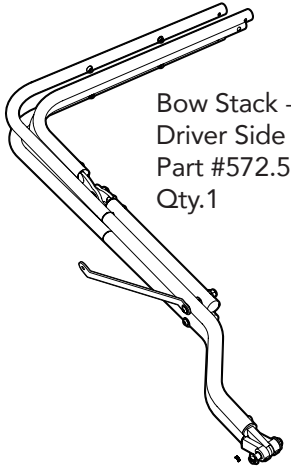
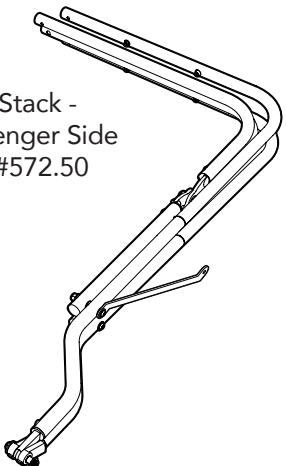
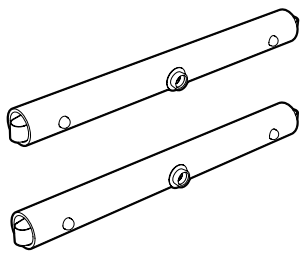
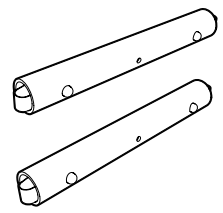
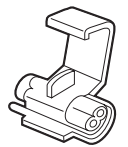
Parts List

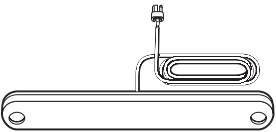
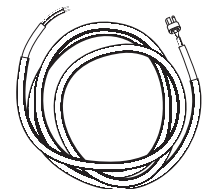
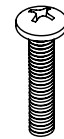
- Required parts for installation - Page number in Installation Guide

Sections 5 to 17 Bow Stacks, Bow Couplers, CHMSL Hardware				
 <p>Bow Stack - Driver Side Part #572.51 Qty.1</p>	 <p>Bow Stack - Passenger Side Part #572.50 Qty.1</p>	 <p>Bow Coupler #1 & #4 Bows Part #576.04 Qty. 2</p>	 <p>Bow Coupler #2 & #3 Bows Part #576.05 Qty. 2</p>	 <p>Wire Tap Part #577.58 Qty. 2</p>

Sections 12 to 17 CHMSL; Wire Harness & Wire Tap; Top, Window, Side Curtains	
<div style="display: flex; justify-content: space-around;"> <div data-bbox="157 1088 430 1315">  <p>Center High-Mount Stop Light Qty. 1</p> </div> <div data-bbox="493 1071 693 1331">  <p>29' Wire Harness Qty. 1</p> </div> <div data-bbox="766 1039 1008 1396">  <p>#10-32 Screw Qty. 2</p>  <p>Flat Washer Qty. 2</p>  <p>#10-32 Nut Qty. 2</p> </div> </div> <div style="text-align: center; margin-top: 20px;"> <p>Parts Kit #576.71</p> </div>	

Section 1 Assemble Side Rails; Remove Paper Backing from Foam Tape

Step 1 200.50 436.16 518.33

Hardware

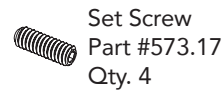
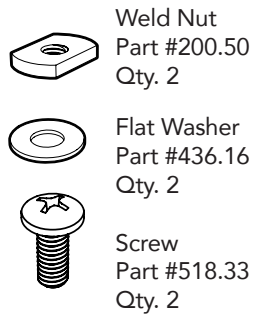

Front Side Rail
Part #574.71 - Left (shown)
Part #574.70 - Right
Qty. 1 of each

Rear Side Rail
Part #574.69 - Left (shown)
Part #574.68 - Right
Qty. 1 of each

Step 2 574.68 574.69 574.70
574.71

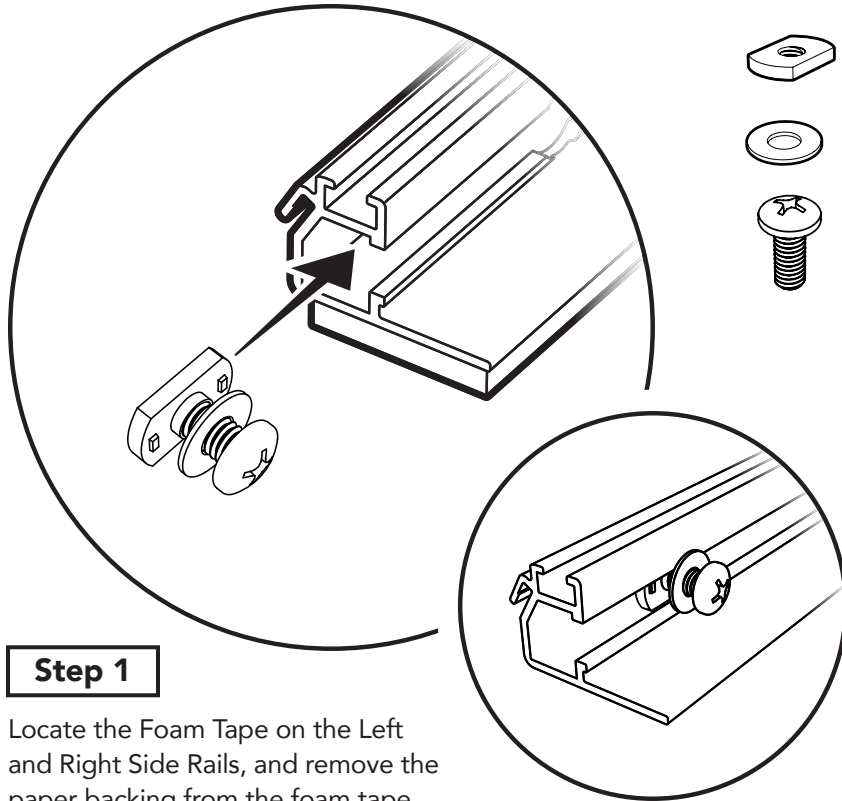

Step 1

Locate the Foam Tape on the Left and Right Side Rails, and remove the paper backing from the foam tape.

Loosely assemble the Weld Nuts #200.50, Flat Washers #436.16, and the Screws #518.33.

Slide each Weld Nut assembly into the left and right Front Side Rails, making sure that the Weld Nut is inside the rail, and the Flat Washer and Screw head are outside the rail, as shown. Leave the assembly loose, so that it will slide in the rail.

Repeat with the both Side Rails.

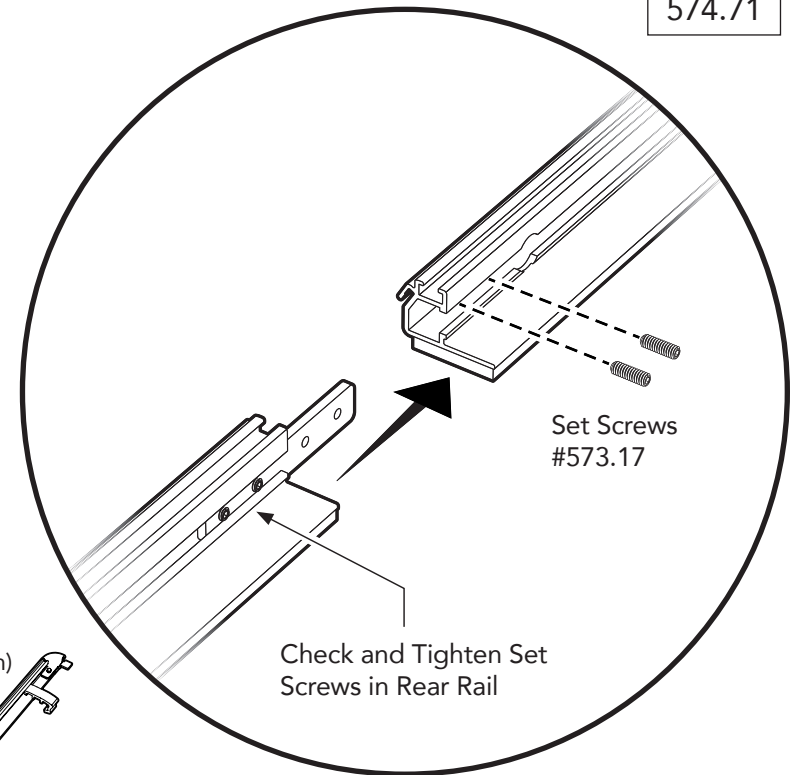

Step 2

Assemble the Left Front Side Rail #574.71 and the Left Rear Side Rail #574.69.

Slide the rails together, and secure using two set screws #573.17.

Check and tighten the two (2) set screws in the rear rail.

Repeat with the Right Side Rails.

Tools



Section 2 Attach Front & Rear Rails; Attach Side Rail Assemblies

Step 1 Front & Rear Rails

Hardware

Step 2 Side Rail Assemblies

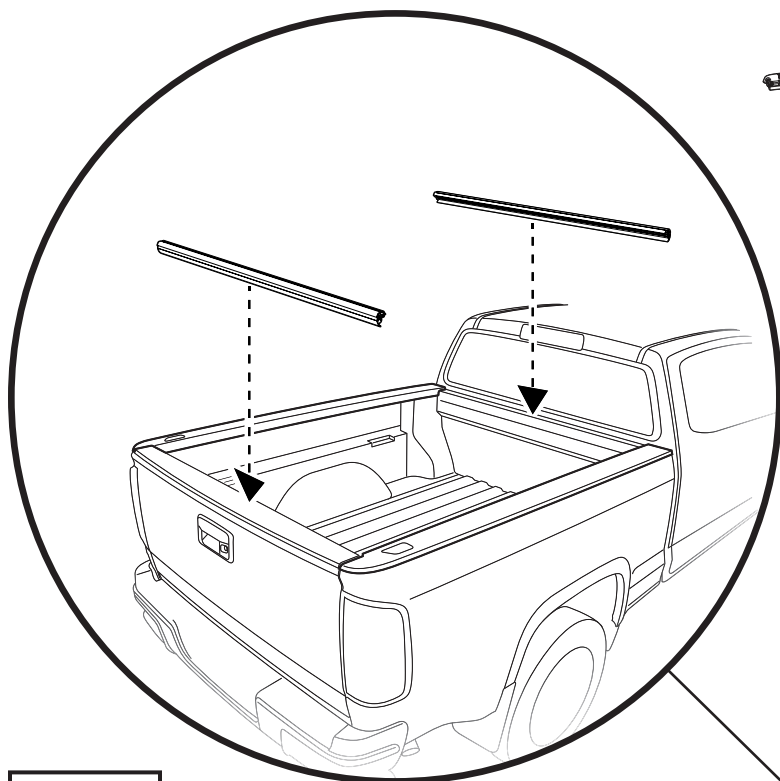

Side Rail Assemblies
Qty. 1 of each



Front Rail
Part #574.77
Qty. 1



Rear Rail
Part #574.78
Qty. 1

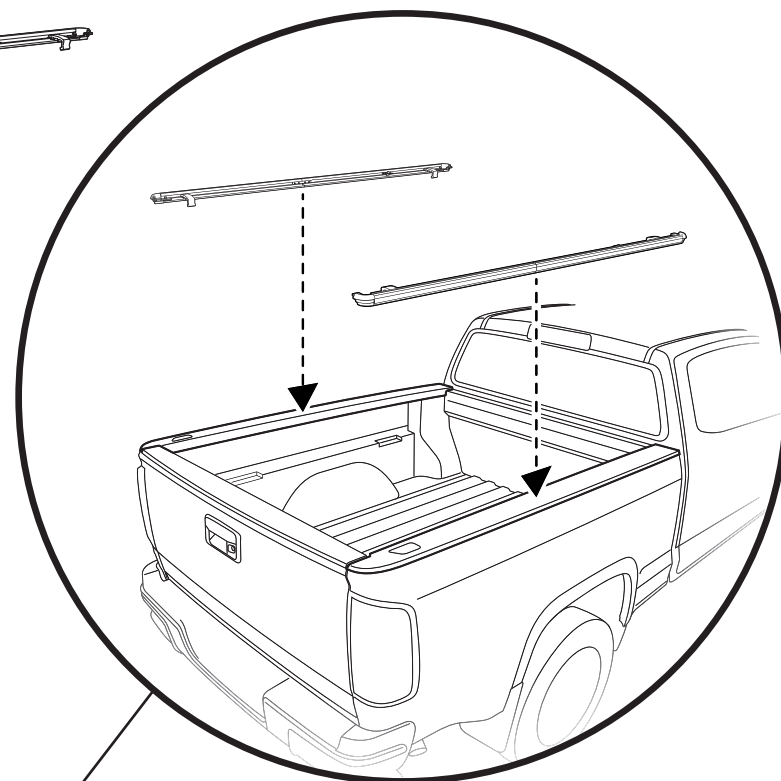

Step 1

Place the Front Rail #574.77 and Rear Rail #574.78 onto the truck bed.

Lay the Rails on top of the truck bed in front, and on top of the plastic bed protector at the rear.

NOTE: The Front Rail is longer than the Rear Rail.

Step 2

Place Side Rail assemblies onto the truck bed. Lay the Rails on top of the plastic bed protectors.

Attach the Side Rails to the Front and Rear Rails.

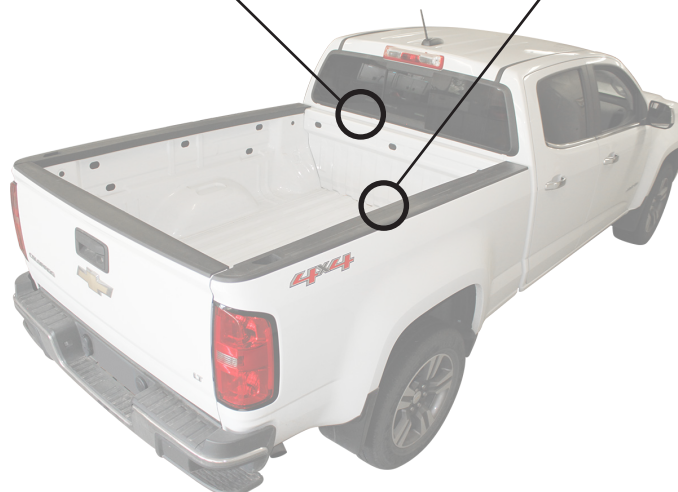

Section 2 Attach Front & Rear Rails; Attach Side Rail Assemblies (cont.)

Step 1

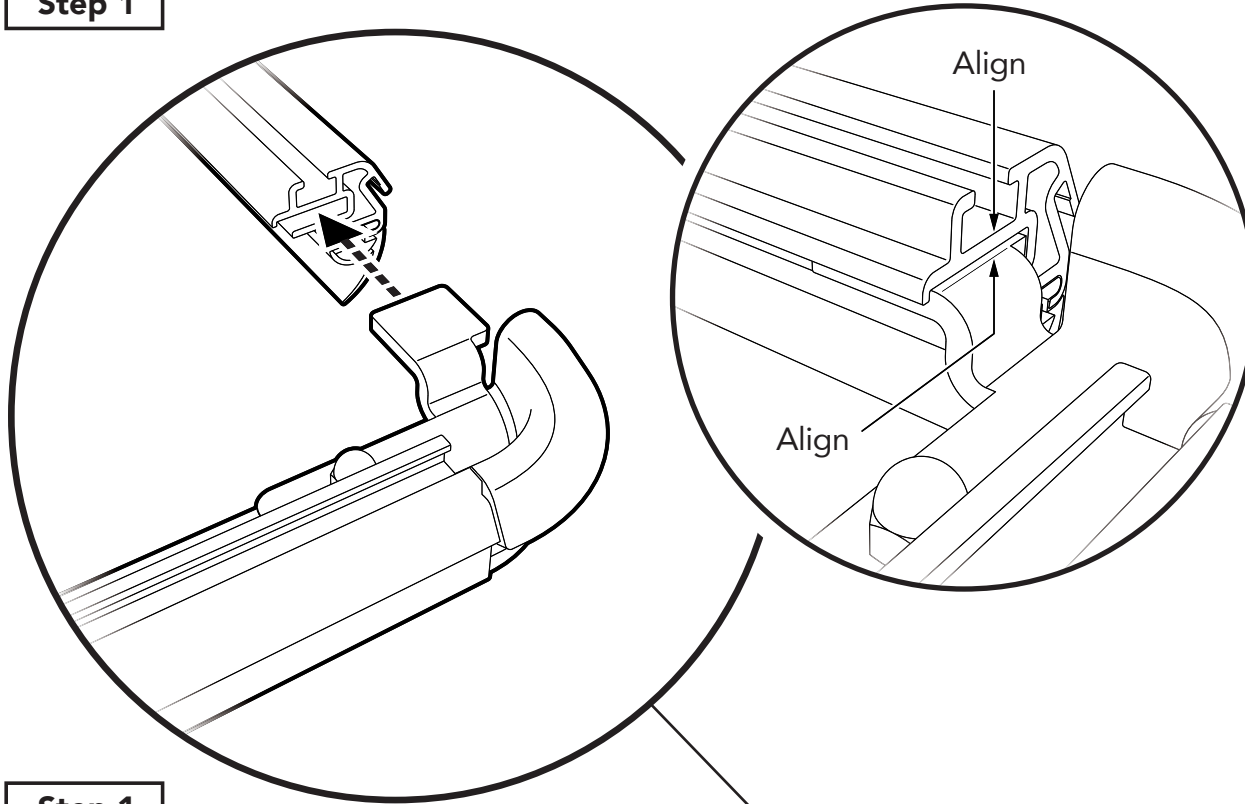

Step 1

Attach the Front and Rear Rails to the Side Rail Assemblies.

Slide the tabs at the front and rear of the Side Rail Assemblies into the slots in the Front and Rear Rails.

Make sure that the ends of the Front Rail and Rear Rail extrusions are aligned with the tongue of the attachment feature, where the tongue bends, and the small corner protrudes.

Step 2

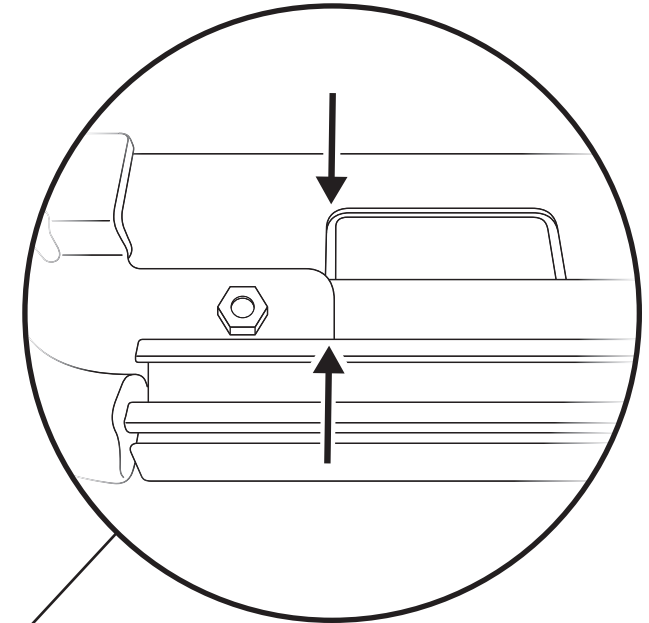

Step 2

Align the edge of the flanges at the front of each Side Rail Assembly with the forward edge of the recessed line in the top of the plastic bed protector, as shown in the diagram above.

Align the Side Rails on both sides of the vehicle.



Section 3 Adjust Rails; Install Clamp Pads

Step 1 Rail Assembly

Hardware

Step 2 577.39

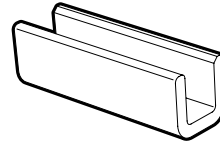
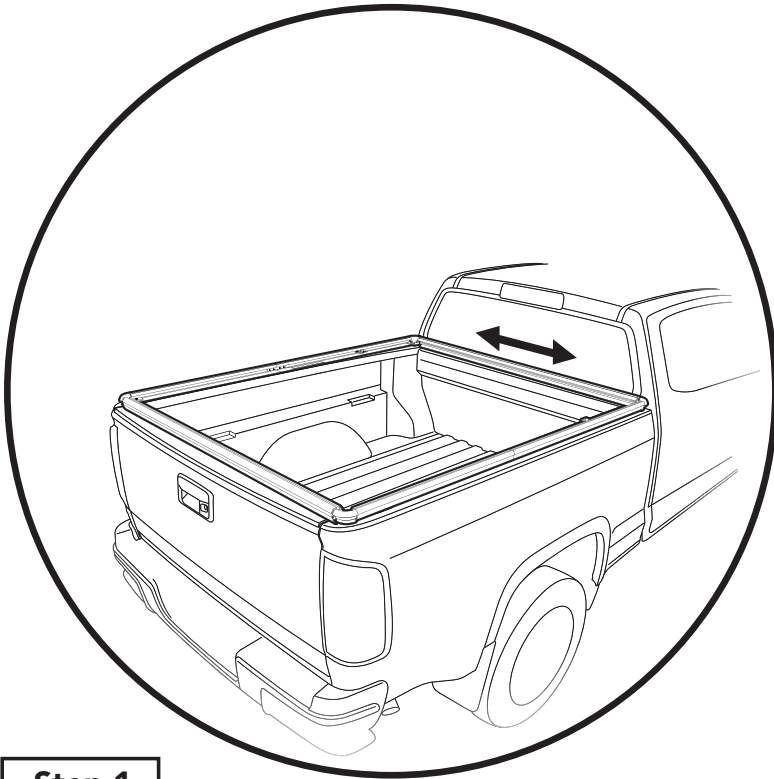

Clamp Pad
Part #577.39
Qty. 2

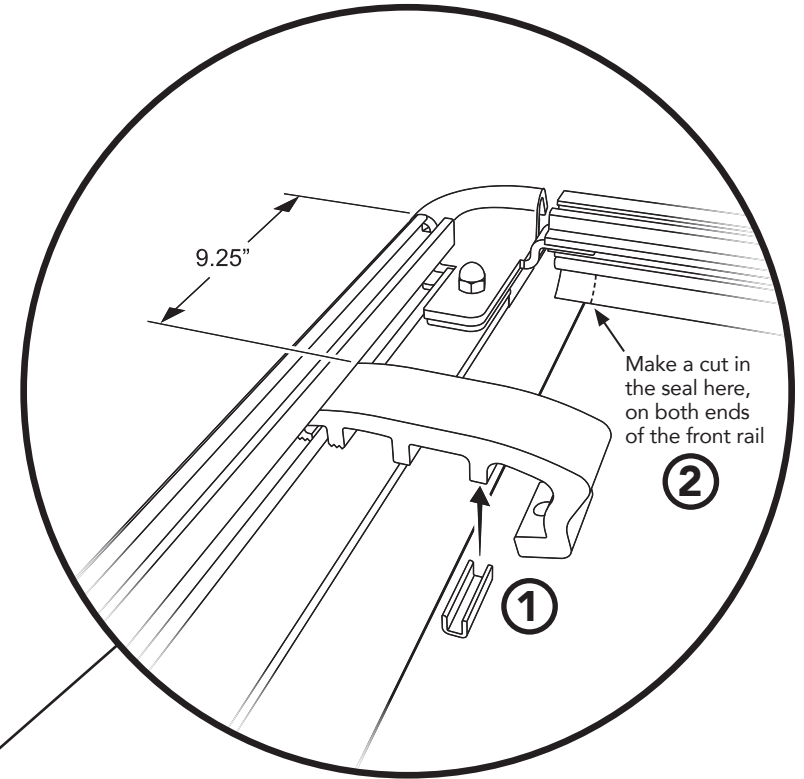

Step 1

Adjust the Side and Front and Rear Rail assembly right-to-left to center it on the bed width.

Step 2

① Attach Clamp Pads #577.39 to the Upper Clamps on the Front Side Rails, on the rib farthest from the rail.

Front Clamp should be located 9.25" from the end of the Front Side Rail.

The Clamp Pads must rest on top of the bed rail cap after installation.

② Make two cuts in the seal on the bottom of the front rail, in line with the inner edge of the bed rail cap, so that the seal will lay flat against the bed bulkhead.



Section 4 Install Rubber Pads; Attach Lower Clamps

Step 1 720035

Hardware

Step 2 579.23 578.39

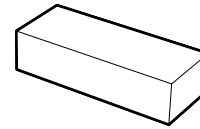
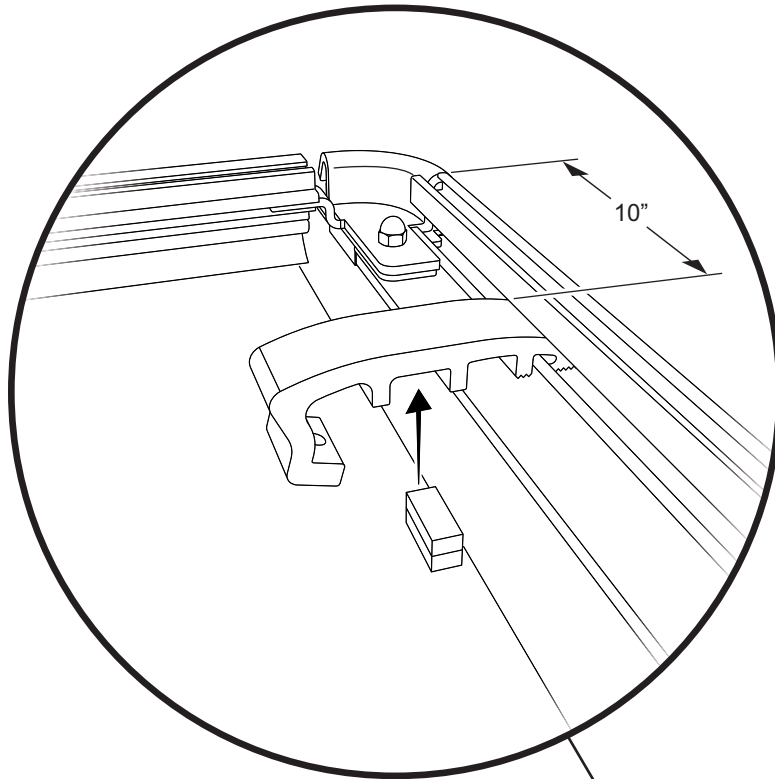

Rubber Pad
Part #720035
Qty. 4

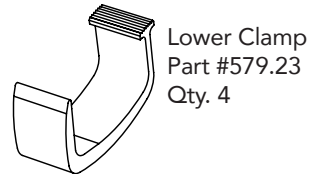

Lower Clamp
Part #579.23
Qty. 4



Hex Head Bolt
Part #578.39
Qty. 4

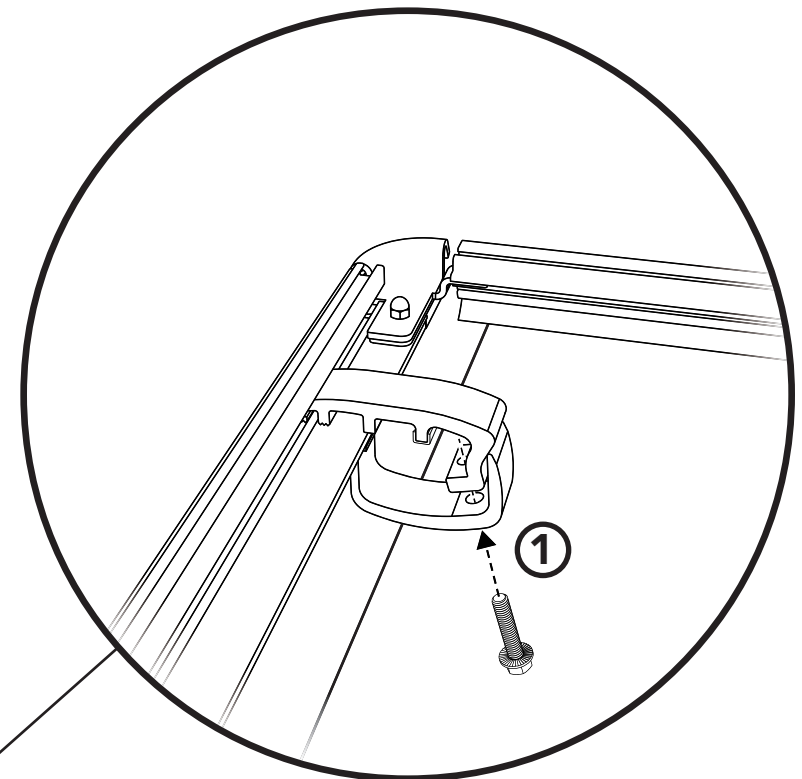

Step 1

Attach two (2) Rubber Pads #720035 together, and stick them to the Rear Rail Clamp, between the rib farthest from the rail, and the next rib.

The rubber pads must rest on top of the bed rail cap after installation.

Rear Clamp should be located 10" from the end of the Rear Side Rail.

NOTE: Make sure that the Rubber Pads are lined up on top of the vehicle's bed rail cap.



Step 2

① Attach Lower Clamps #579.23 to the pre-assembled Upper Clamps on the Side Rails, using one (1) Hex Head Bolt #578.39 for each clamp.

Check alignment of the Rail Assembly and tighten all bolts.

Section 5 Assemble Bows

Step 1 576.04 576.05 572.50

Hardware

Step 2 572.51 572.50

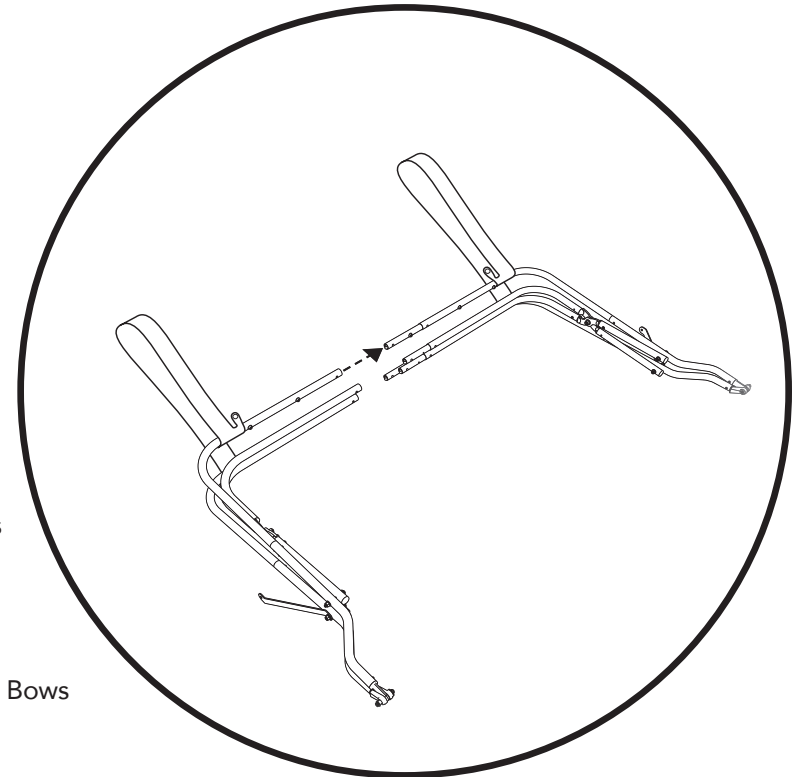
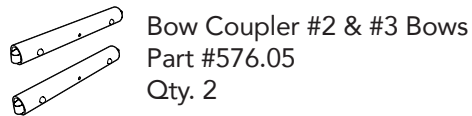
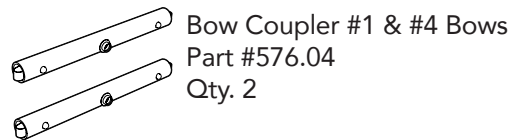
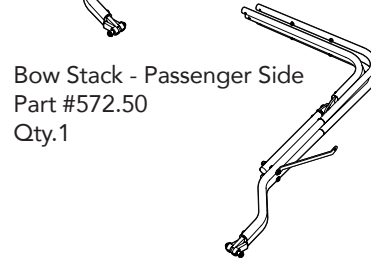
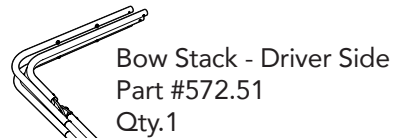
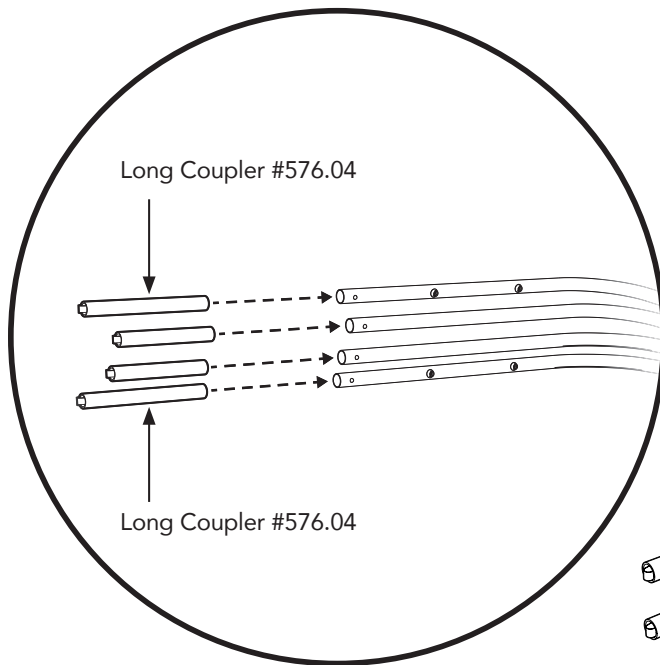

Step 1

Attach Bow Couplers #576.04 and #576.05 to the Passenger Side Bow Stack #572.50.

Insert Long Couplers #576.04 into the outer bows #1 and #4.

Insert Short Couplers #576.05 into the inner bows #2 and #3.

For Easier Installation:

Slide all bows and couplers together before snapping the spring clips into the holes in the bows.



Step 2

Attach Driver Side Bow Stack #572.51 to Passenger Side Bow Stack #572.50.

Bow Stacks attach using the Couplers installed in Step 1.

Slide the Couplers installed in the Passenger Side Bow Stack into the ends of the bows on the Drivers Side Bow Stack.

NOTE: Before attaching couplers to bow stacks, make sure to pull the bond coat straps out and away from the bows, and lay them flat.

Section 6 Install Bow Assembly

Step 1 Bow Assembly

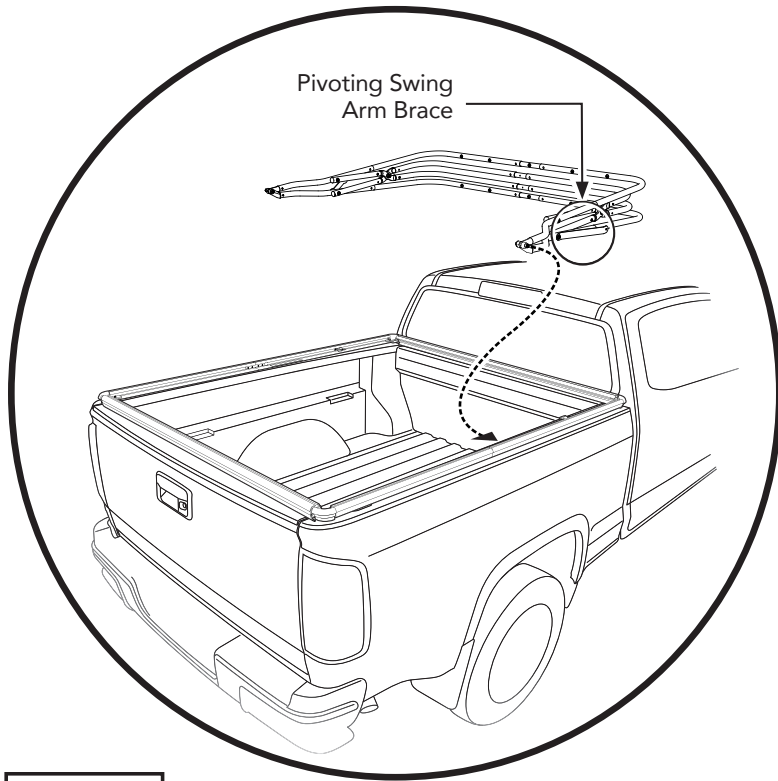

Details

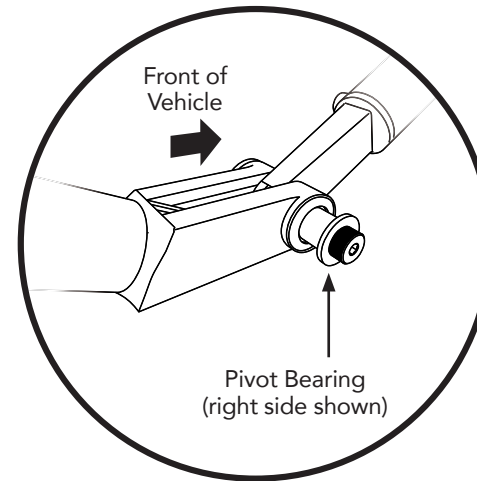

Details

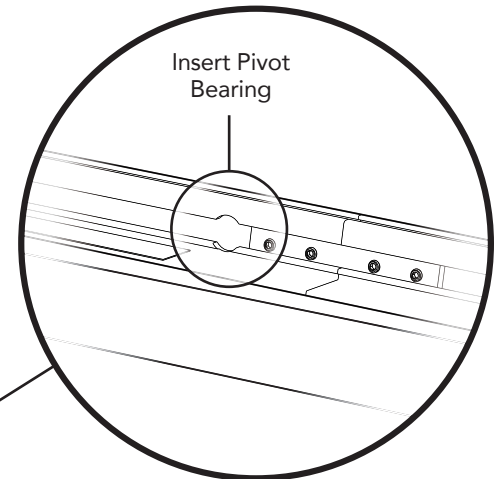

Step 1

NOTE: Two People Are Required for This Portion of the Installation Process.

Place the folded Bow Assembly on the Side Rails. Make sure that the pivot swing arm braces are on the lowest bow.

Insert the Pivot Bearings into the receiving holes in the inside of the side rails (see details).



Section 7 Unfold Bows; Attach Pivot Arm Brace

Step 1

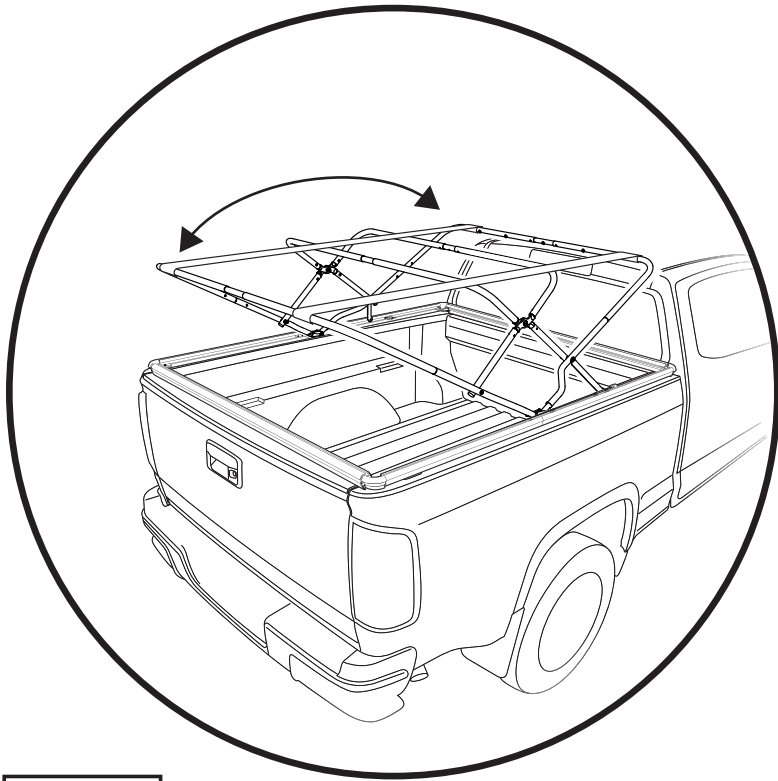

Step 1

Unfold the Bow Assembly.

Step 2

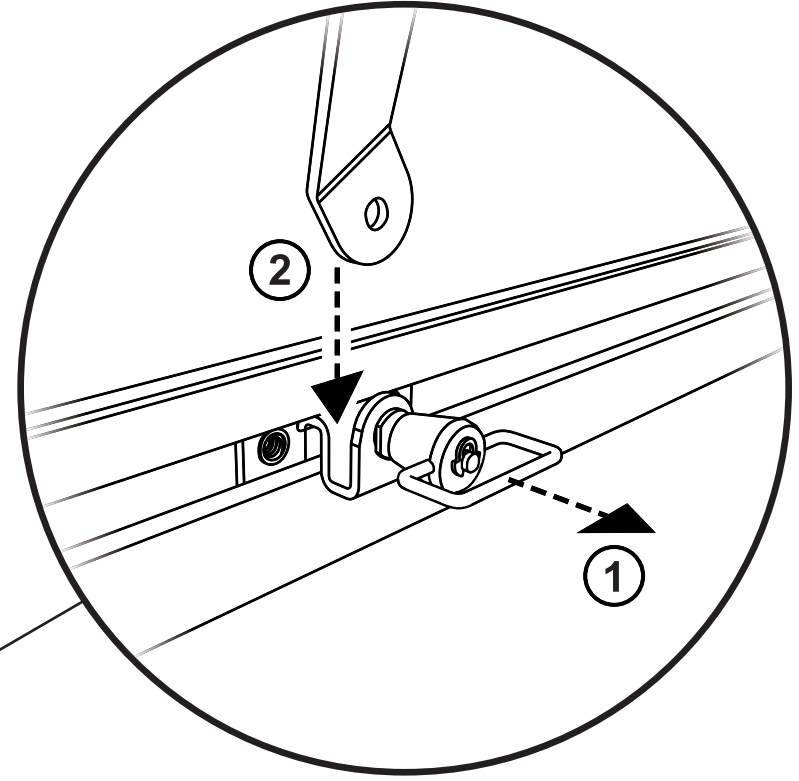

Step 2

- ① Pull back on the Pivot Knuckle release knob;
- ② Snap the Pivot Arm Brace into place, on both sides of the truck.

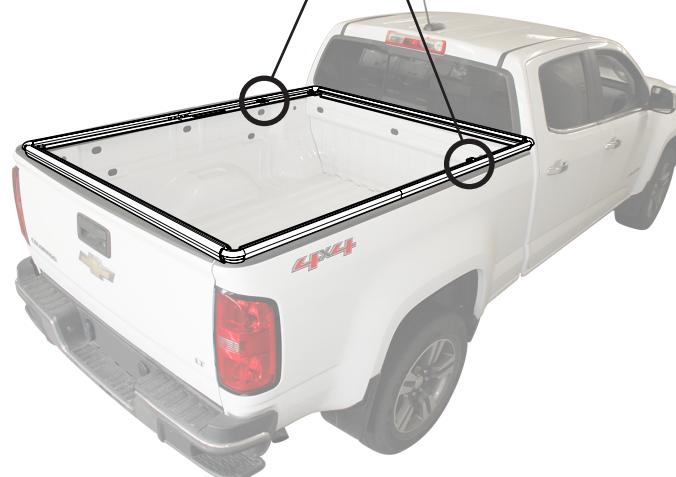

Section 8 Lay Folded Top Fabric on Bows; Unfold Top Fabric

Step 1

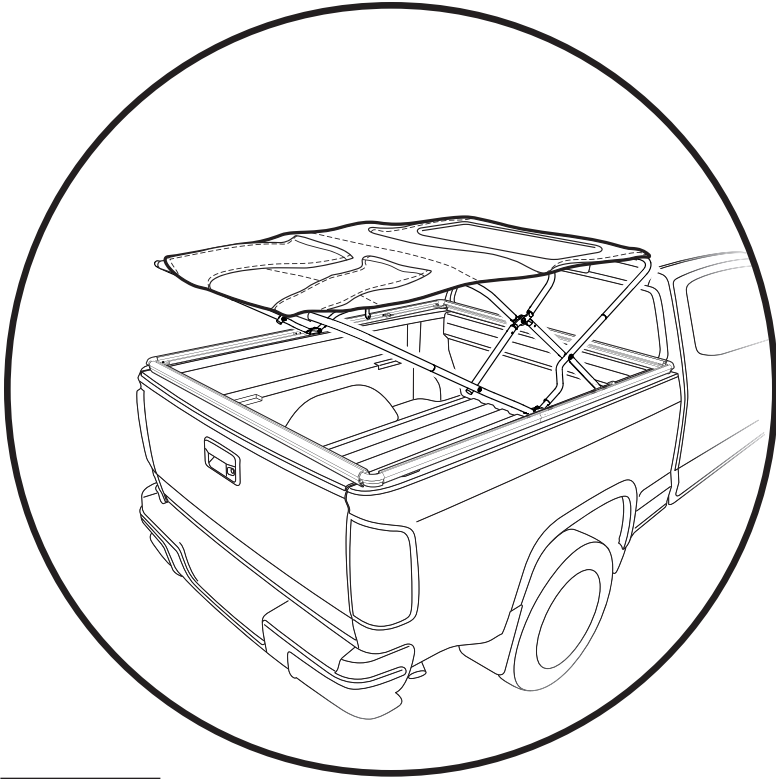

Step 1

Place the folded Soft Top onto the unfolded Bow Assembly.

Step 2

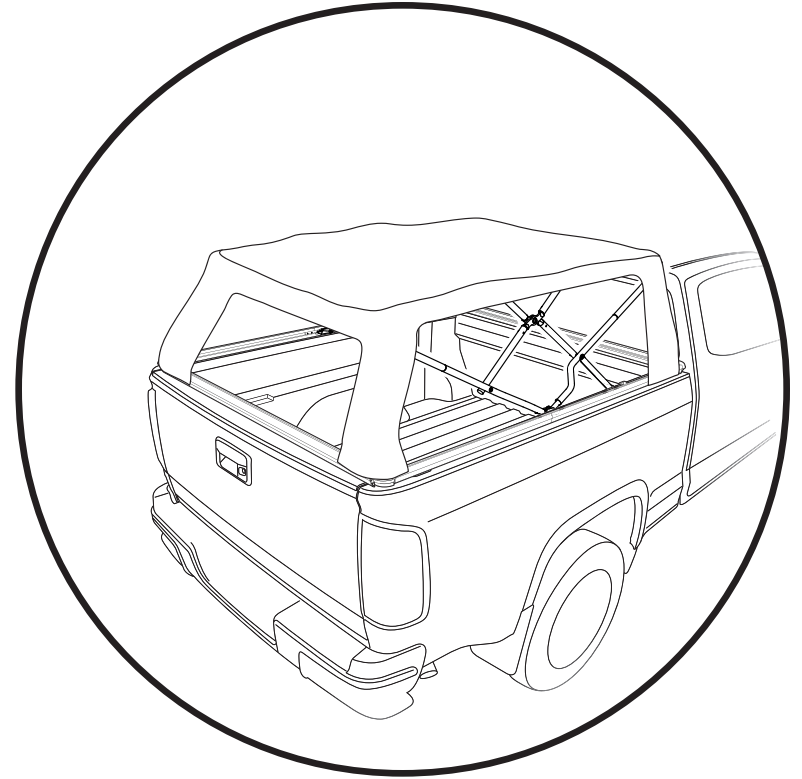

Step 2

Unfold the front and back of the Top over the #1 and #4 Bows.



Section 9 Secure Top Fabric to Bows

Step 1

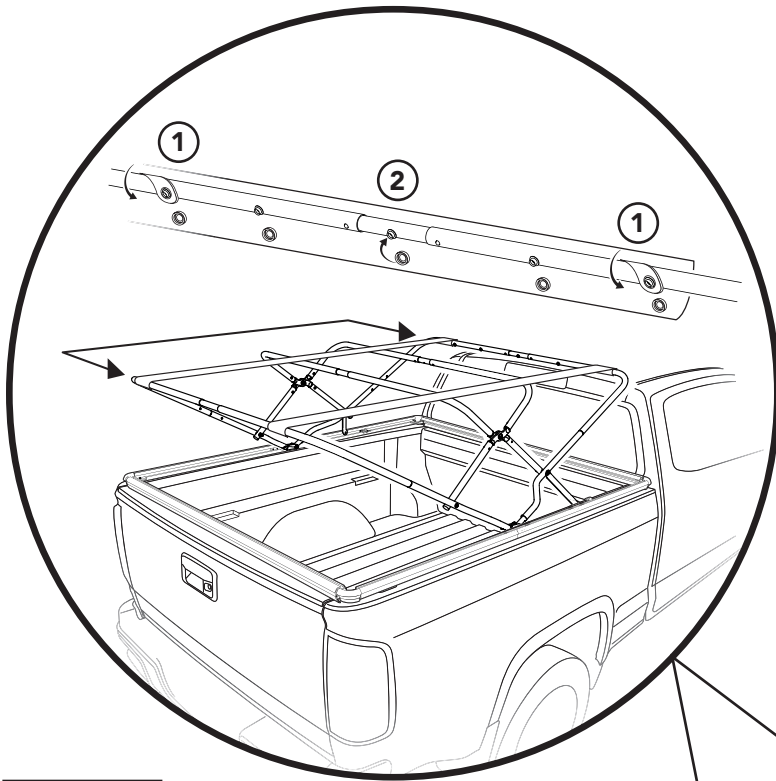

Step 1

From inside the truck bed:

- ① Wrap the small flaps with holes over the outer-most snaps on the #1 bow (Bow closest to the truck cab).
- ② Wrap the fabric flap around the #1 Bow and snap all five snaps to secure the fabric to the Bow.

NOTE: Secure the outer snaps before securing the center snaps.

Repeat for the #4 Bow (Bow closest to the truck tailgate).

Step 2

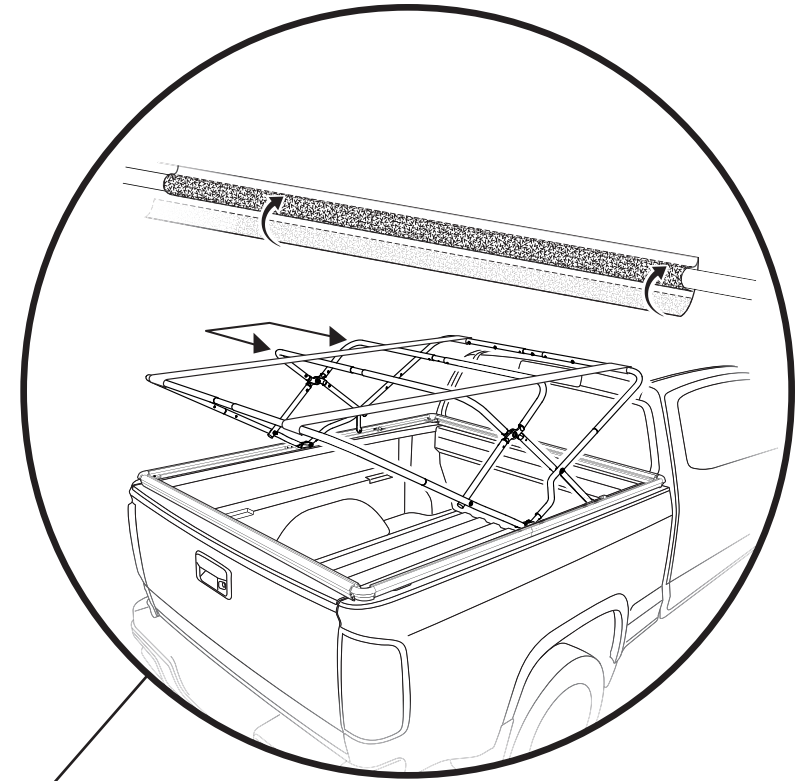

Step 2

From inside the truck bed:

Wrap the fabric flaps with hook-and-loop around the #2 and #3 bows (the two middle bows) to secure the top fabric to these Bows.

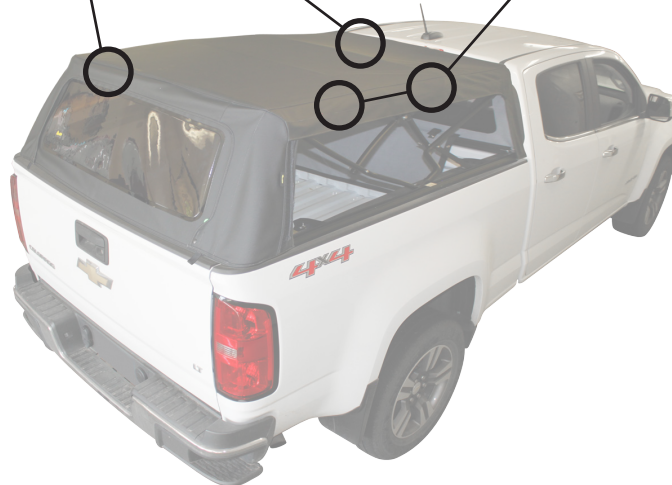

Section 10 Slide Front Rail into Front Window

Step 1

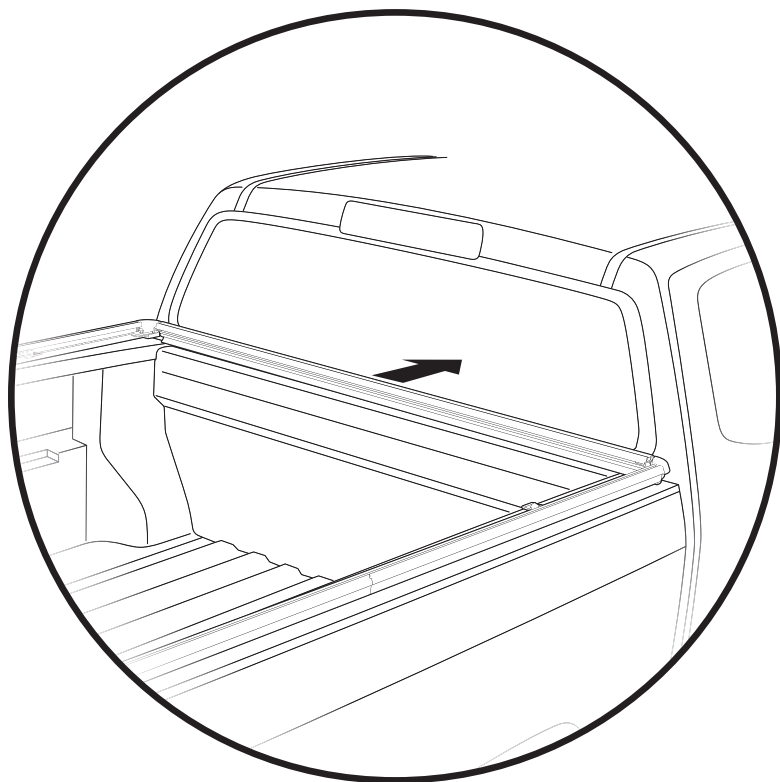

Step 1

Remove the front rail, by sliding it toward the front of the truck bed.

Step 2

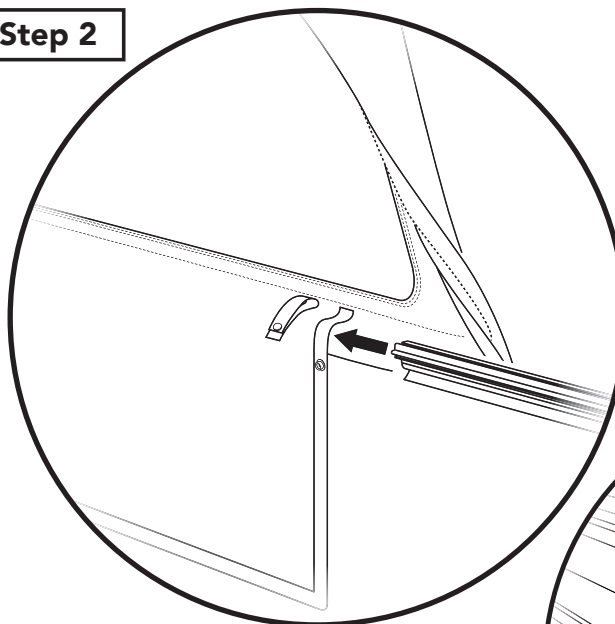

Detail

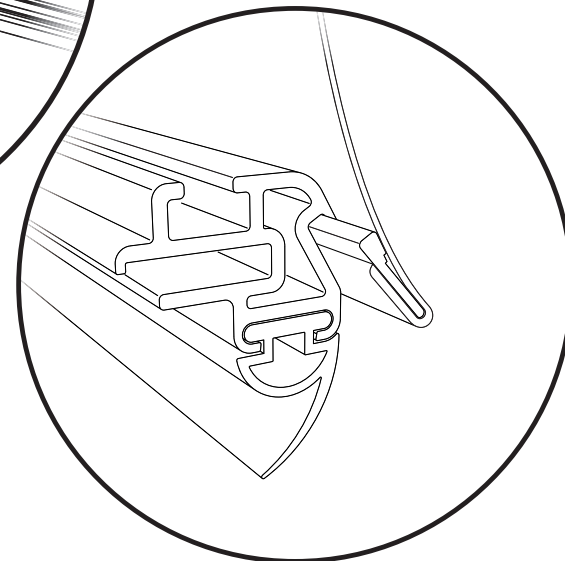

Step 2

Slide the Front Rail into the sleeve at the bottom of the Front Window, and re-attach it at the front of the Side Rails.

The Front Rail extrusion should slide over the plastic tab along the bottom of the front window. See Detail above.



Section 11 Tuck Plastic Tabs at Bottom of Curtains and Corners into Rails

Step 1

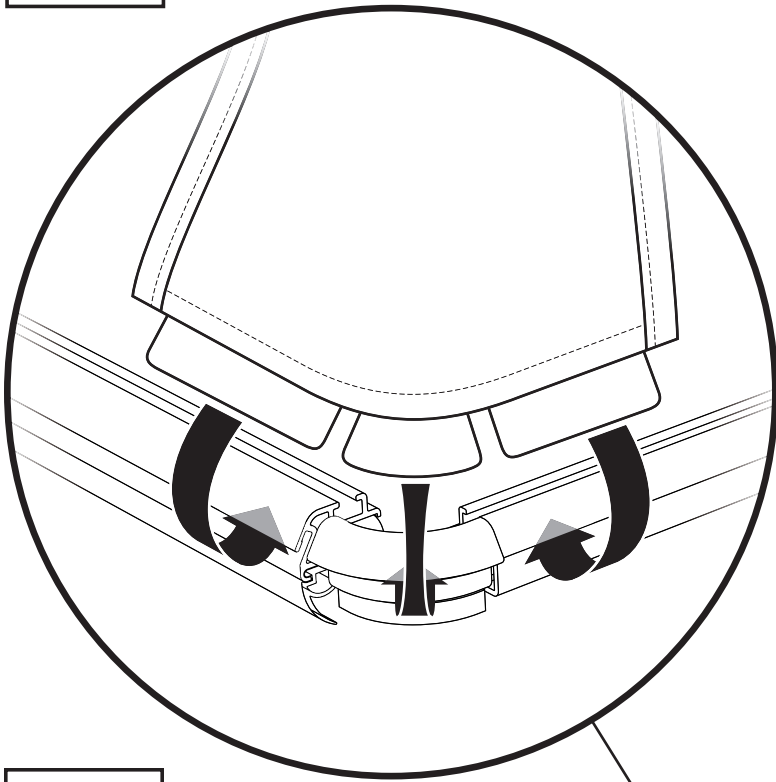

Step 1

Tuck the plastic tabs at the bottom of each corner of the top into the slots in the Side Rails and Front and Rear Rails.

Step 2

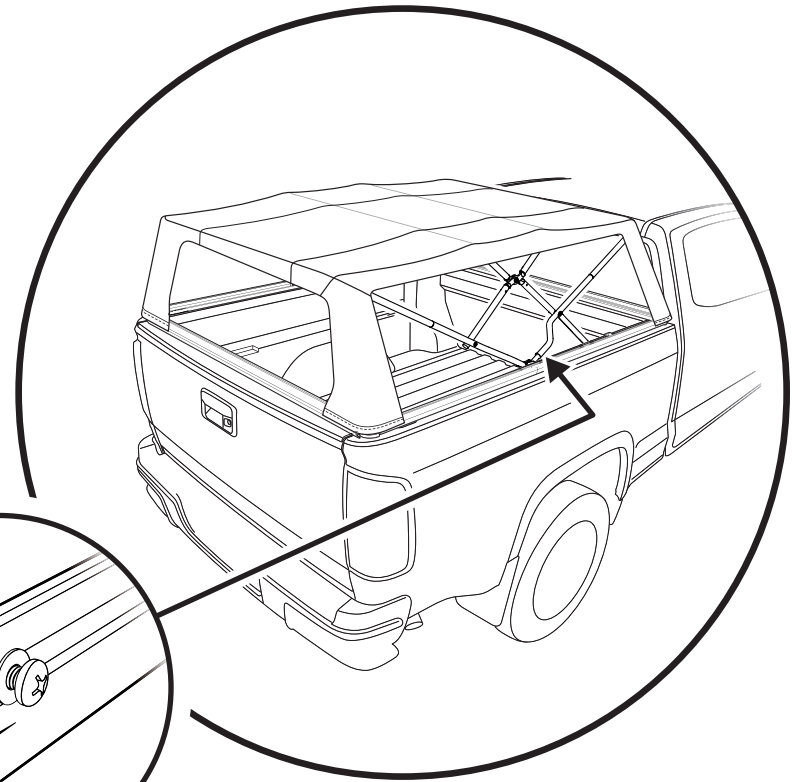

Step 2

After the top has been installed and adjusted, and is up, locate the two Screw-Washer-Weld Nut assemblies you installed in Section 1.

Slide these assemblies rearward until they stop at the Bow Assembly, and then tighten the screws.

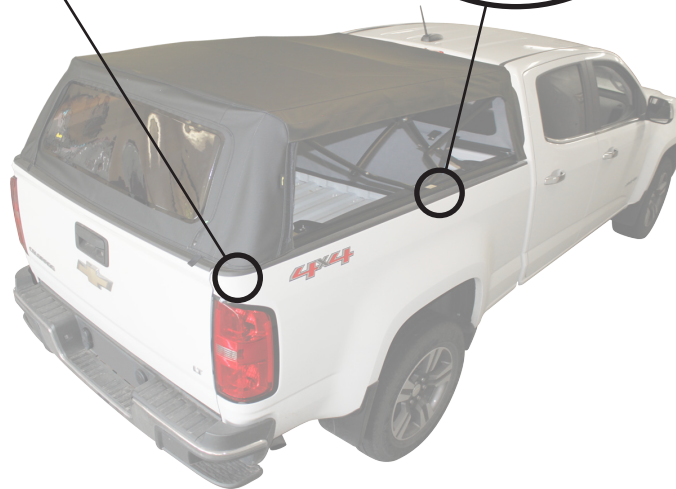

Section 12 Tighten Adjustment Screws; Install Side Curtains

Step 1

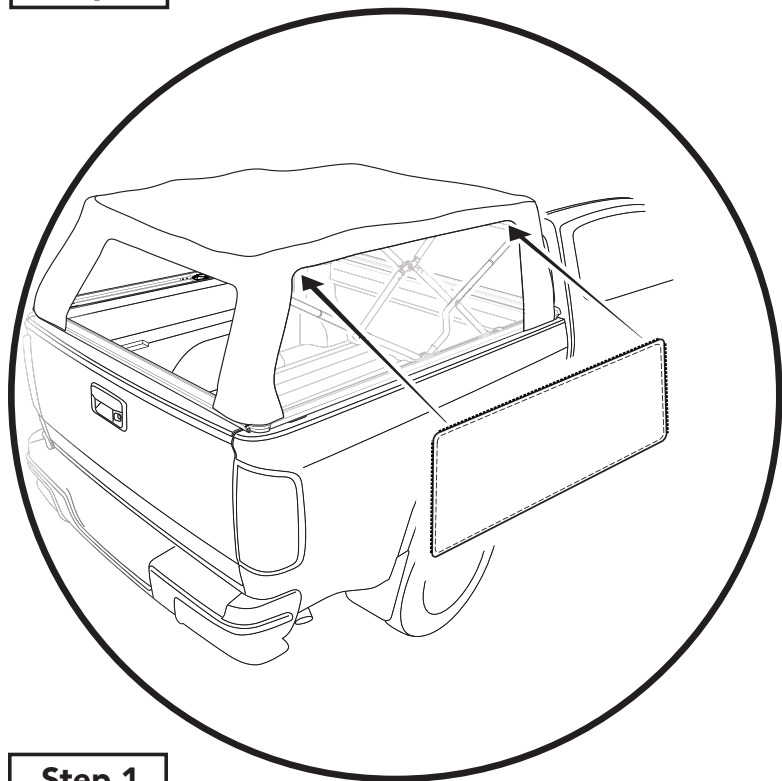

Step 1

Zip the Rear Window and Side Curtains into place.

Start with the zipper along the top edge of each panel, and then follow with the side zippers.

For easier access to the zippers, you may want to lift the corners of the top onto the roof fabric.

Step 2

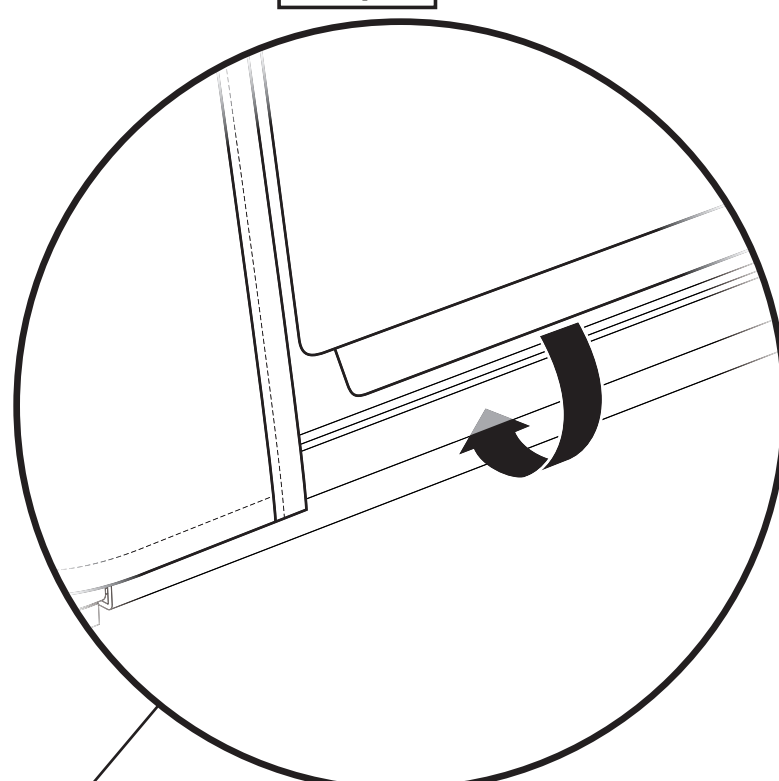

Step 2

Tuck the plastic tab along the bottom edge of each Side Curtain into the slot along the side of each Side Rail.

Tuck the plastic tab along the bottom of the Rear Window into the slot along the side of the Rear Rail.



Section 13 Install Center High-Mount Stop Light

Step 1

Hardware Kit #576.71

Step 2 CHMSL

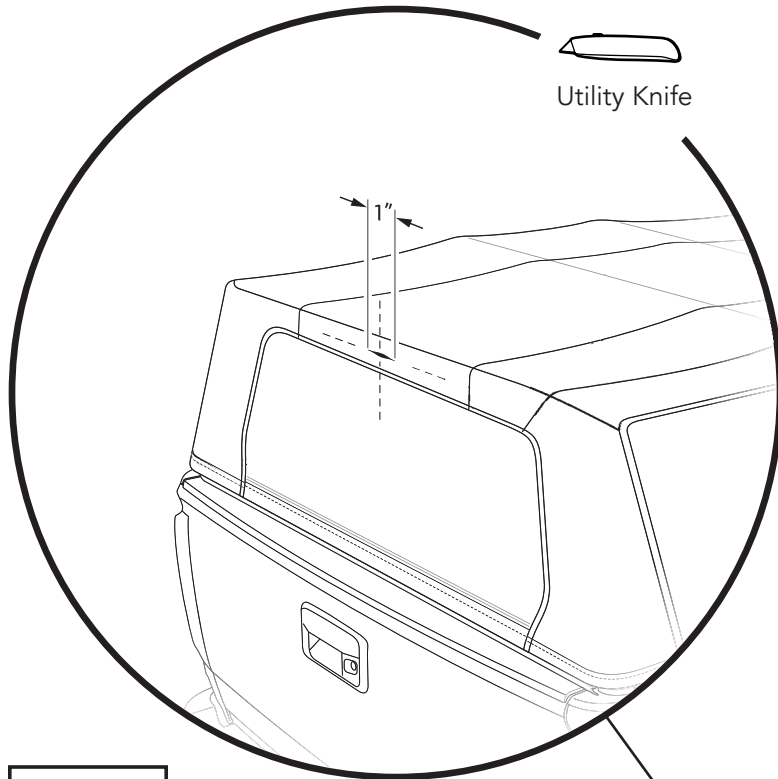

Utility Knife

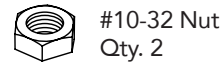
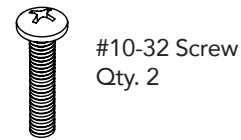
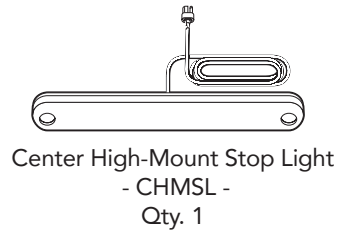

Step 1

Using a utility knife, cut a 1" wide slit through both layers of fabric in the area above the middle of the rear window, and in the vertical center of the fabric.



Step 2

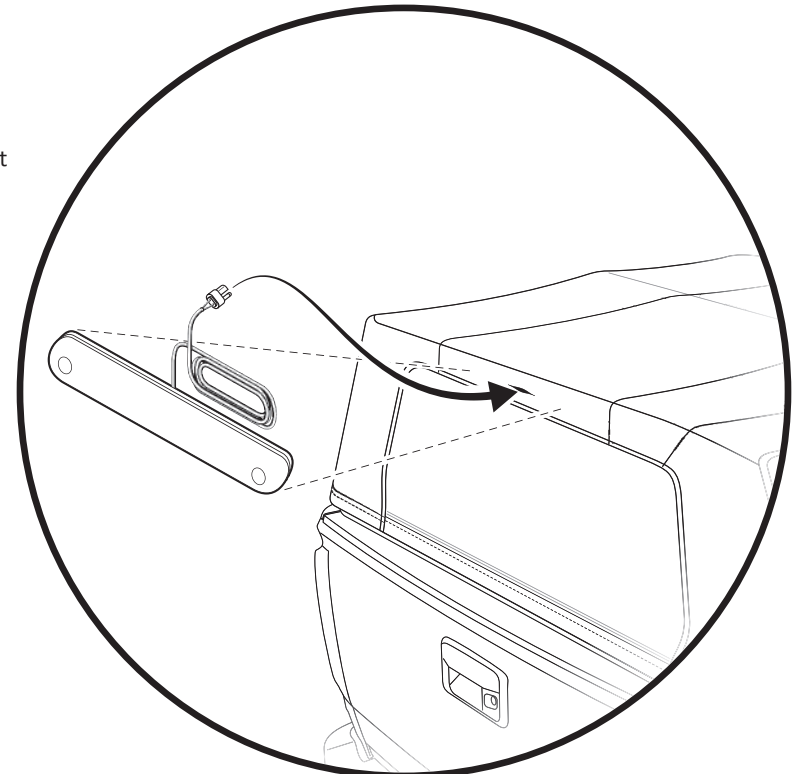

Feed the connector end of the CHMSL wire harness through the slit in the top fabric, and pull the wire all the way through.

Make sure that the light is centered, straight and level, and attach the Stop Light to the top fabric using two (2) 10-32 Screws, two (2) Flat Washers and two (2) 10-32 Nuts. The Nuts and Flat Washers go on the inside of the fabric.

You'll need to pierce the fabric for the screws to go through.

Section 14 Feed Wire Harness Through Sleeves

Step 1

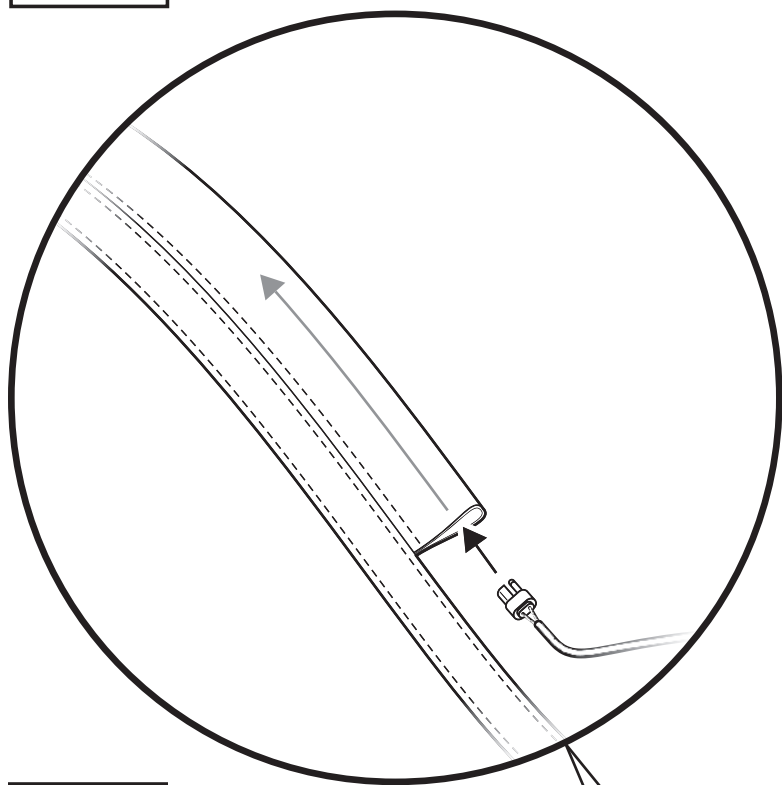

Detail

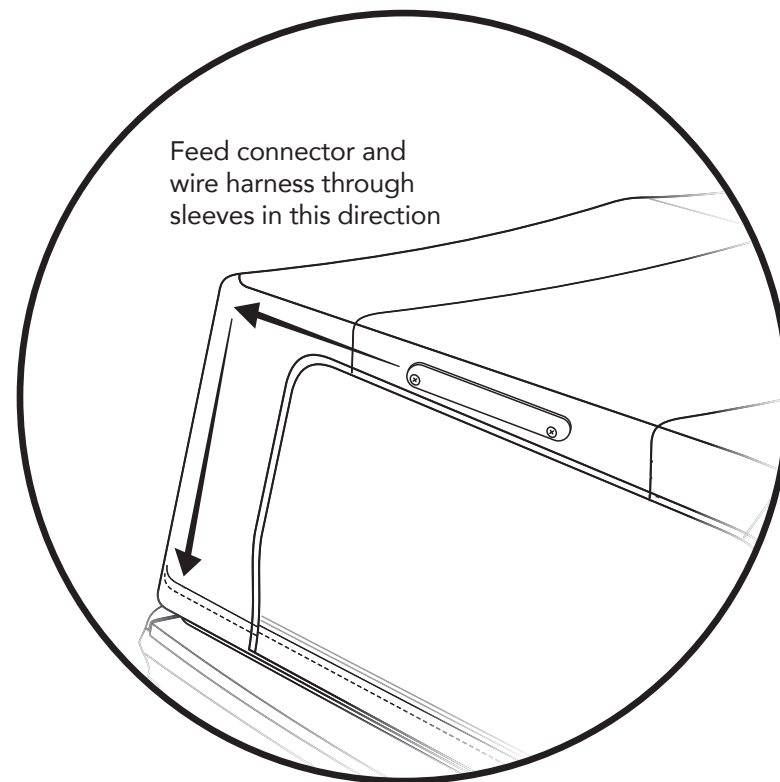

Step 1

Feed the connector and wire harness through the fabric sleeves on the inside of the top.

The sleeves run across the top and down the rear corner of the top fabric.
(See Detail)



Section 15 Install 29' Wire Harness & Splice Into Existing Wiring (Option 1)

Step 1

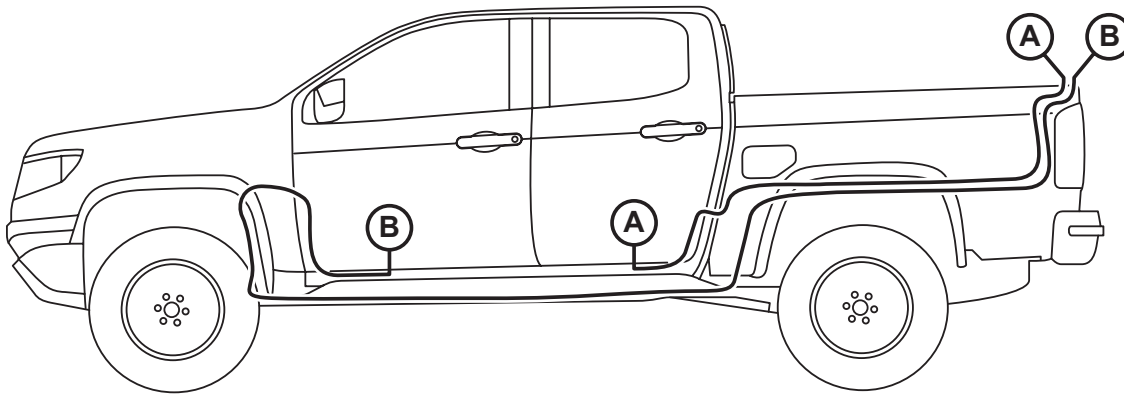

Step 1

Route the 29' Wire Harness using either Route **A** or Route **B**.

Route **A**: Wire goes through rear cab vent, behind the rear seat, and under the rear driver's side door sill.

Route **B**: Wire goes along vehicle frame and into engine compartment, through the firewall, then down and under the front driver's side door sill.

Hardware

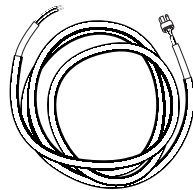

29' Wire Harness
Qty. 1



Wire Tap
Part #577.58
Qty. 2



Wire Ties
(Not included)

Step 2

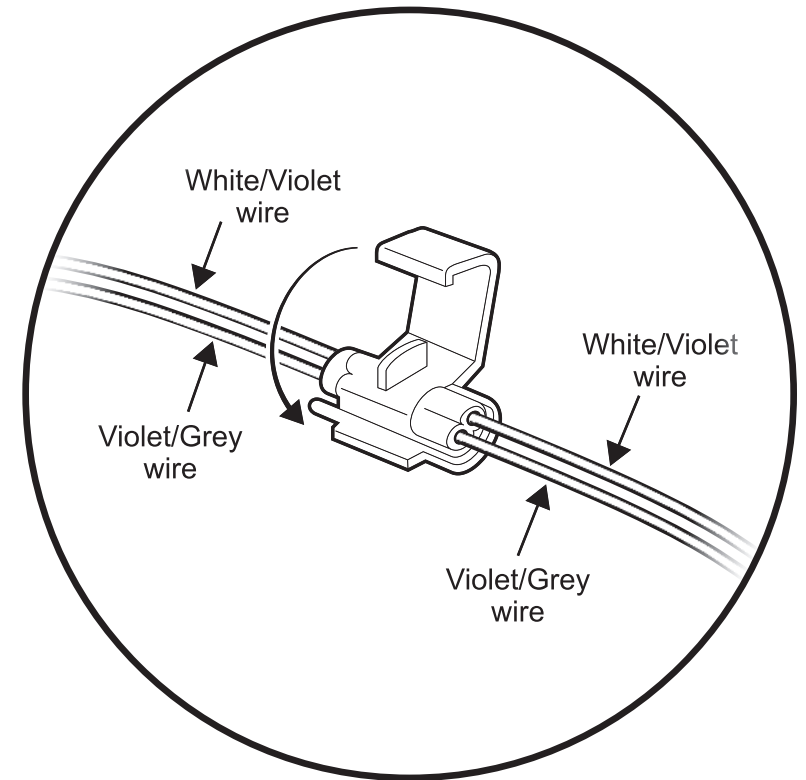

Step 2

Under the door sill, locate the White/Violet and the Violet/Grey wires.

Splice the same-color wires together from the 29' wire harness to these two wires, using the Wire Tap #577.78.

Section 16 Attach 29' Wire Harness to Vehicle UEC (Option 2)

Step 1

Hardware

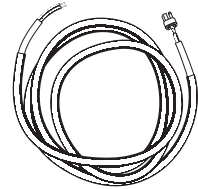

29' Wire Harness
Qty. 1

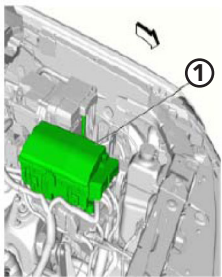

1. The 29' Wire Harness is used to provide CHMSL function to the Supertop-mounted CHMSL.
2. The harness routing starts with the 3-way connector mounted to the inboard side of the UEC (1) (Underhood Electrical Center) with terminals pointing rearward.

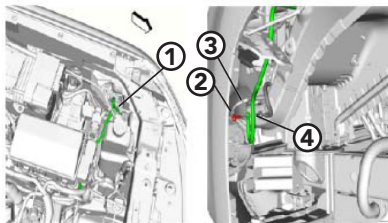

1. The ground eyelet will route forward and the two loose terminals will route rearward.
2. Remove the left front tire and wheel house splash shield to access the ground location. Refer to the Vehicle Service Manual.
3. Route the harness (1) with ground eyelet downward to the left front wheel house area.
4. The ground eyelet will attach to the ground (4) just forward of the left front wheel.
5. Remove the existing ground bolt (2), stack the new eyelet (3) and replace the ground bolt, tighten the bolt to 23N.m (17 lb-ft.).

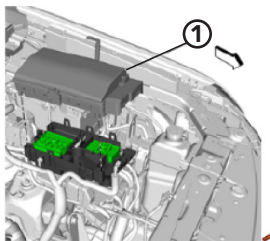

1. The two loose terminals route around the rear and into the UEC. The current CHMSL on the rear of the cab needs to be disabled, because the Supertop will block it from being viewed from behind. The new CHMSL attached to the Supertop will replace it.
2. Remove the top of the UEC, exposing the large connectors below.
3. Locate the CHMSL circuit (Violet/Grey wires) in cavity 75 of connector X.
4. Remove the terminal from cavity 75 and replace it with the larger of the two terminals on the new accessory harness.
5. Cover the terminal that was removed and the un-needed terminal from the accessory harness with vinyl tape and store them out of the way.

Section 17 Plug CHMSL Wire Harness Connectors Together

Step 1

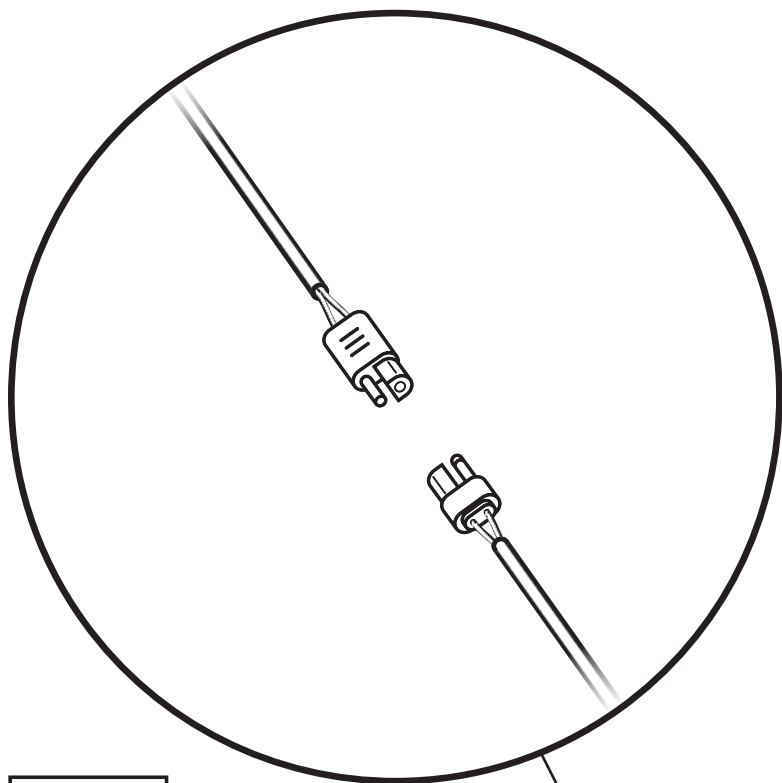

Step 1

After routing the 29' Wire Harness using either Option 1 or Option 2, plug the 2-conductor connectors at the ends of the CHMSL Wire Harness and the 29' Wire Harness together.

NOTE: You must unplug these connectors before folding the top down.



Section 18 Opening and Storing the Top

Step 1

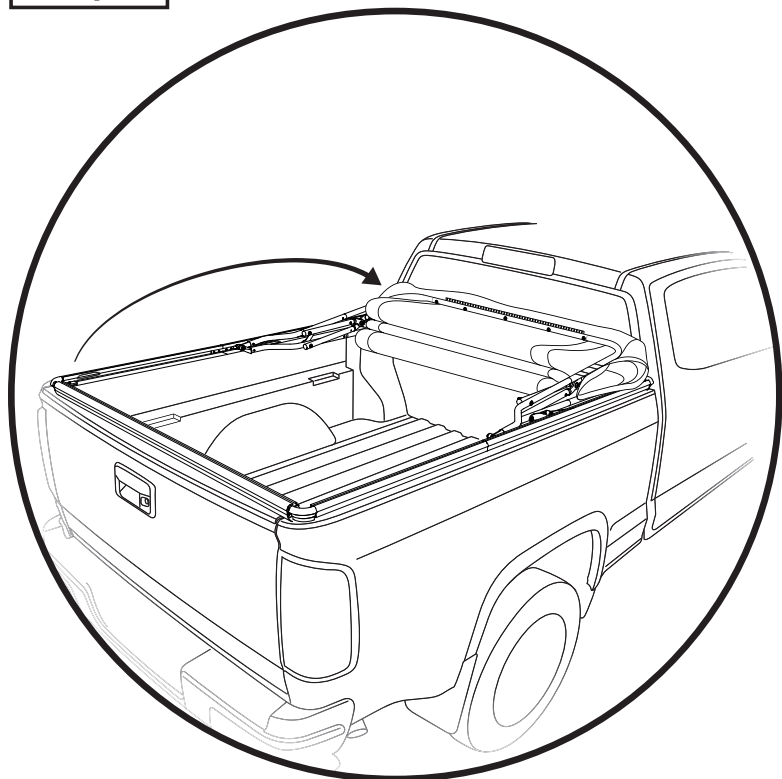

Step 1

To open the top:

Unzip and remove Side Curtains.

Unzip and remove Rear Window.

Release plastic tabs from rails all around.

Flip rear corners of top fabric up onto roof.

Fold the top forward so that all the bows collapse and rest on the Front Rail.

Step 2

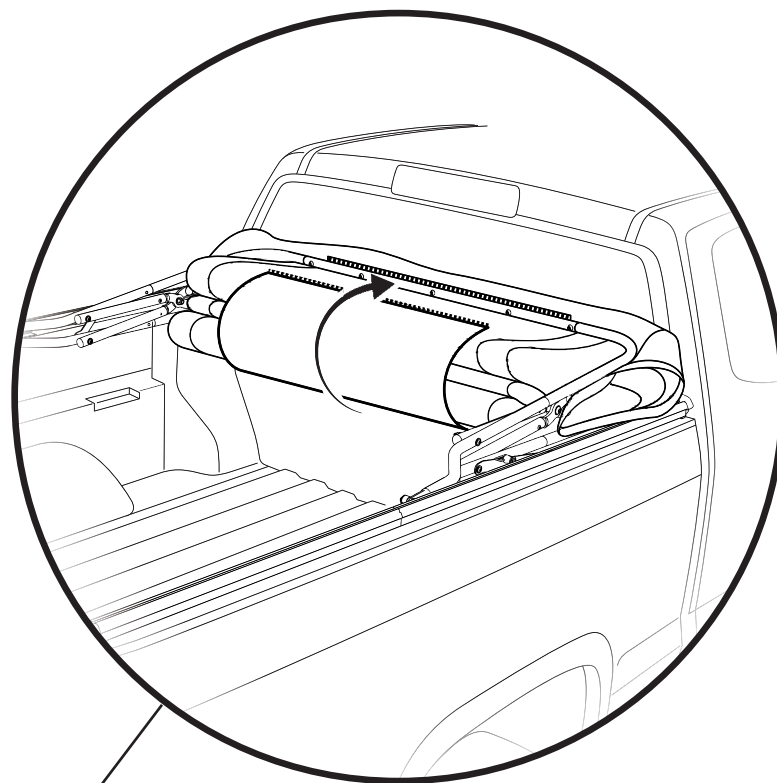

Step 2

Protect the top fabric by wrapping the Boot attached to the Front Window around the Fabric and Bows.

Secure the Boot by zipping it to the zipper for the Rear Window.



Section 19 Store Rear Rail When Top is Folded Down

Step 1

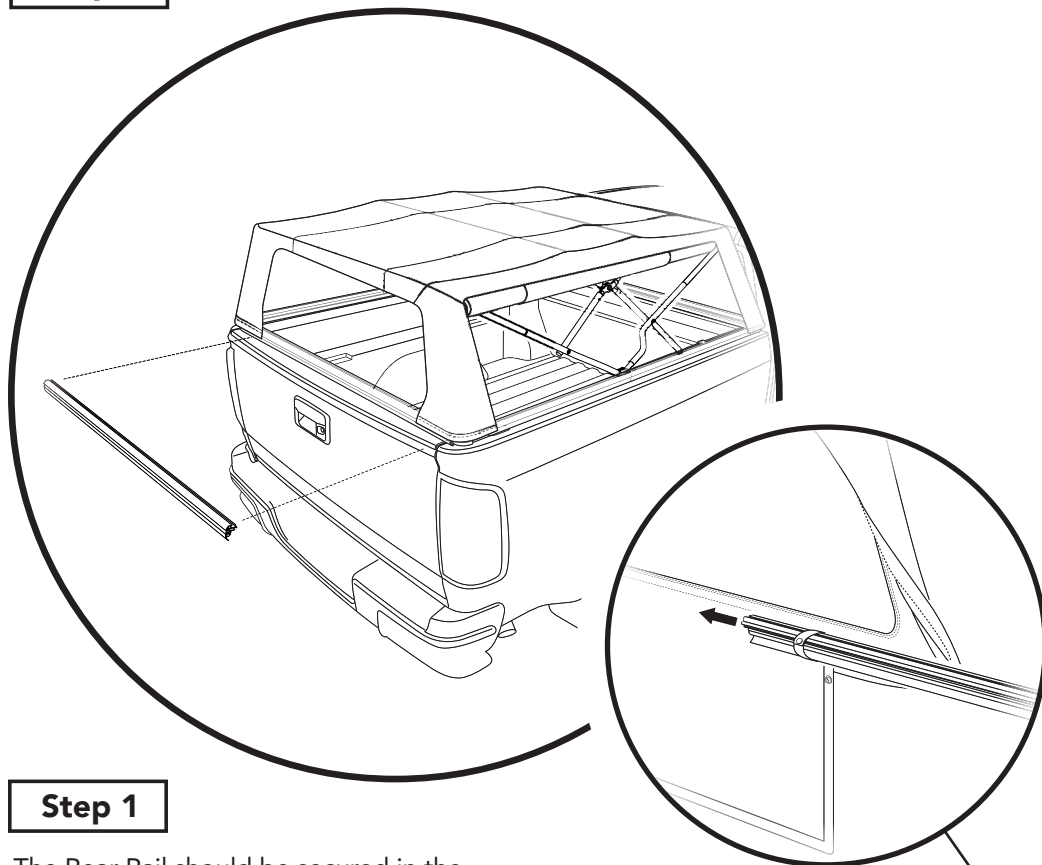

Step 1

The Rear Rail should be secured in the straps at the bottom of the Front Window when the top is folded down.

Wrap the straps around the Rear Rail and snap closed.



Section 20 Storing the Rear Window; Rolling Up Side Curtains

Step 1



Step 1

With the Fabric Top up, the Rear Window can be stored in the Boot attached to the bottom of the Front Window.

Place the rolled-up Rear Window in the Boot, and zip the Boot closed.

Step 2

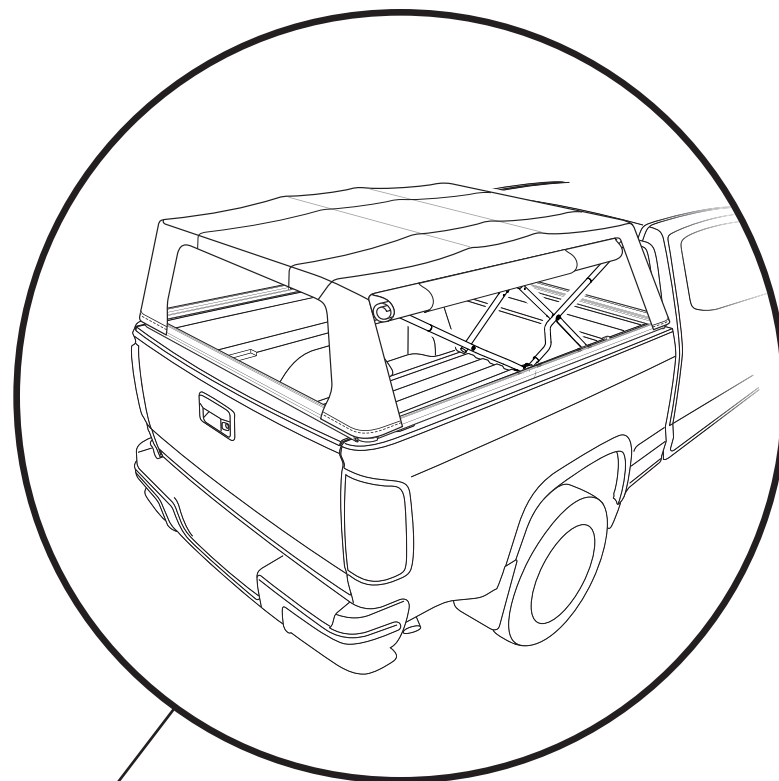

Step 2

With the Fabric Top up, the Side Curtains can be rolled up and secured with attached side flaps.

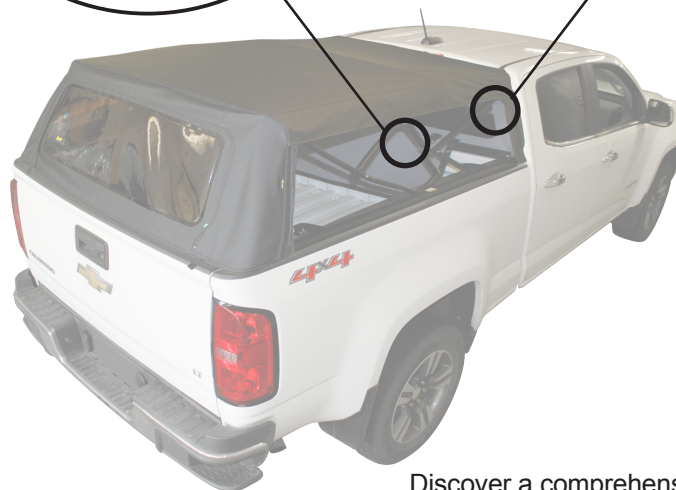

Discover a comprehensive collection of truck bed accessories on our website.