



### IMPORTANT! READ THIS FIRST!

Installation of shock absorbers or other suspension components requires special tools and expert knowledge. Accordingly, installation of all BILSTEIN products must be performed by a professional automotive suspension technician.

When replacing other brands, BILSTEIN shock absorbers or other suspension components should always be installed as a set. All BILSTEIN products must only be used for the specific, intended application as indicated in the application guide. **Any use of any BILSTEIN product other than for its intended use may result in serious bodily injury or death.**

Always use a chassis hoist for the installation of BILSTEIN products and make certain that the raised vehicle is securely attached to the hoist and/or supported to prevent the vehicle from slipping, falling, or moving during the installation process.

**If you install any BILSTEIN product without the necessary special tools, expertise, and chassis hoist, you may subject yourself to the risk of serious bodily injury or death.**

BILSTEIN shock absorbers are gas-filled and are highly pressurized.

- Never place any BILSTEIN shock absorbers in a vise or use a clamp on any BILSTEIN shock absorber.
- Never apply heat near any BILSTEIN shock absorber.
- Never attempt to open or repair any BILSTEIN product, in order to prevent **serious bodily injury or death.**

Any attempt to misuse, misapply, modify, or tamper with any BILSTEIN suspension product voids any warranty and **may result in serious bodily injury or death.**

While installing any BILSTEIN product:

- Do not use impact tools for loosening or tightening fasteners, because this may destroy the screw threads.
- Self-locking fasteners must only be used **once!**
- Reuse original equipment components only if they are in good condition, otherwise replace them with new components.
- Never remove the slight film of oil on the shock absorber piston rod and seal.
- All mounting fasteners for shock absorbers and other suspension components must be securely tightened before tension is placed on the suspension system, unless otherwise specified in the manufacturer's service manual or in this instruction.

After installing any BILSTEIN product:

- The suspension caster and camber must be checked and/or adjusted to comply with the vehicle manufacturer's specifications.
- The (load dependent) brake compensator and the anti-lock brake system must be checked and/or reset to comply with the vehicle manufacturer's specifications.
- The headlight aim must be checked and adjusted. Or, if applicable, adaptive headlights must be checked and recalibrated to comply with the vehicle manufacturer's specifications.
- If applicable, any/all Advanced Driver Assistance Systems (ADAS) must be checked and recalibrated to comply with the vehicle manufacturer's specifications.

### **CAUTION for COILOVER TYPE SUSPENSIONS!!!**

**If disassembling a coilover type suspension, refer to the vehicle manufacturer's service manual for proper procedures. The coil spring is preloaded and must be compressed with a spring compressor to release load before the upper mount is disassembled. Failure to follow the vehicle manufacturer's procedures may cause serious injury or death, and may damage the vehicle.**

### **IMPORTANT!!!**

**This BILSTEIN product may or may not be compatible with non-BILSTEIN aftermarket products and/or vehicle modifications. It is the responsibility of the professional automotive suspension technician performing the installation to identify any non-OEM components and/or modifications on the vehicle that may interact with the suspension system. These must be evaluated for any potential physical static or dynamic interference with and/or effect on the function of this BILSTEIN product.**

# E-WM05-000070 MOUNTING INSTRUCTION



## IMPORTANT:

### PLACE CIRCLIP IN APPROPRIATE GROOVE TO ADJUST RIDE HEIGHT.

Use appropriate tools to move the circlip. Ensure that the circlip is fully seated in the groove after moving it (you should be able to rotate it manually in the groove). Install the spring seat in the direction shown only. The circlip must fit completely in the groove inside spring seat (DETAIL A). **Improper installation will cause permanent damage to the shock!**

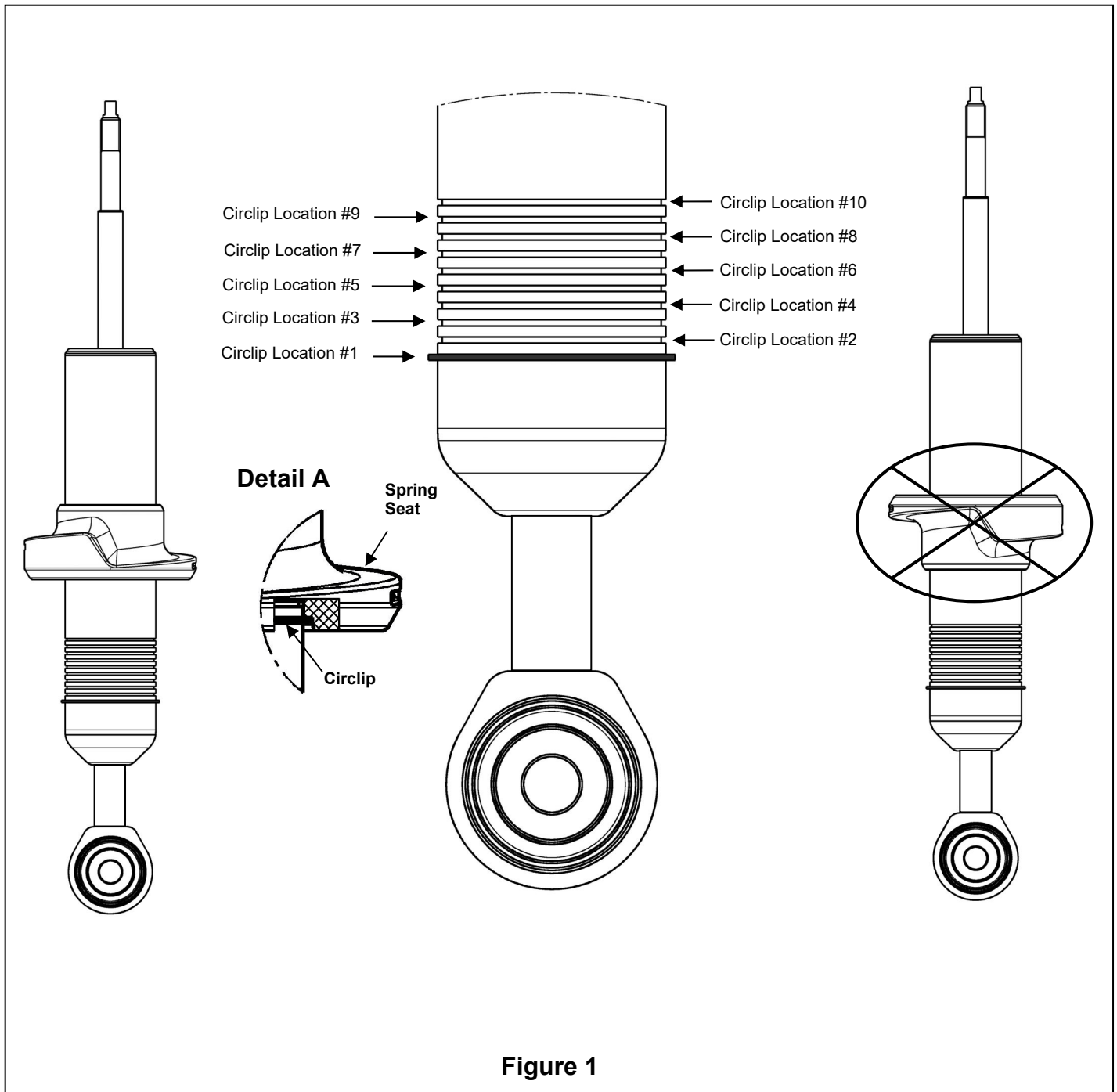



<b>B8 6112 Typical Lift Heights**</b>		
<b>Circlip Location (Both Sides)</b>	<b>Tundra* 4WD, i-FORCE MAX V6 Hybrid, CrewMax, 5.5' or 6.5' bed</b>	<b>Sequoia 4WD/RWD, i-FORCE MAX V6 Hybrid</b>
<b>#10</b>	***See note	***See note
<b>#9</b>	2.2"	***See note
<b>#8</b>	1.9"	***See note
<b>#7</b>	1.5"	***See note
<b>#6</b>	1.2"	***See note
<b>#5</b>	0.9"	***See note
<b>#4</b>	0.5"	3.1"
<b>#3</b>	Stock	2.7"
<b>#2</b>	Do not use	2.4"
<b>#1</b>	Do not use	2.1"

<b>B8 6112 Typical Lift Heights**</b>	
<b>Circlip Location (Driver Side / Passenger Side)</b>	<b>Tundra* 4WD, i-FORCE V6, CrewMax, 5.5' or 6.5' bed</b>
<b>#10 / #9</b>	***See note
<b>#9 / #8</b>	***See note
<b>#8 / #7</b>	2.2"
<b>#7 / #6</b>	1.9"
<b>#6 / #5</b>	1.5"
<b>#5 / #4</b>	1.2"
<b>#4 / #3</b>	0.9"
<b>#3 / #2</b>	0.5"
<b>#2 / #1</b>	Stock

\* Tundra **Capstone** models require an additional circlip location higher than what is listed above to achieve the advertised lift heights.

\*\* Lift heights indicated are typical. Actual lift height is influenced by which factory suspension the vehicle is equipped with and its condition; optional equipment and accessories on your vehicle, and other vehicle modifications such as replacement coil springs, wheel and tire combinations, etc. Modifying/lifting the suspension to your vehicle may raise its center of gravity and may make it more susceptible to loss of control and/or rollover, which may result in death or serious injury. We strongly recommend that you offset the loss of rollover resistance as much as possible by increasing tire track width. Wear seat belts at all times and avoid situations where a side rollover may occur.

\*\*\* **DO NOT USE** this circlip location for stock weight vehicles. However, if substantial additional weight is added to your vehicle (e.g. heavy bumper and winch), and this results in a loss of ride height, this circlip location may be utilized to restore the vehicle to its intended ride height. Subsequently, it is essential that you verify the shock absorber module length at ride height does not exceed the values listed in Figure 2.

# E-WM05-0000070 MOUNTING INSTRUCTION



For **Tundra** models, verify the shock absorber module length specified in Figure 2 below is **less than or equal to 20 9/16" (522mm)**. If the resultant shock absorber module length is greater than 20 9/16" (522mm), a lower circlip location should be used.

For **Sequoia** models, verify the shock absorber module length specified in Figure 2 below is **less than or equal to 20 1/16" (510mm)**. If the resultant shock absorber module length is greater than 20 1/16" (510mm), a lower circlip location should be used.

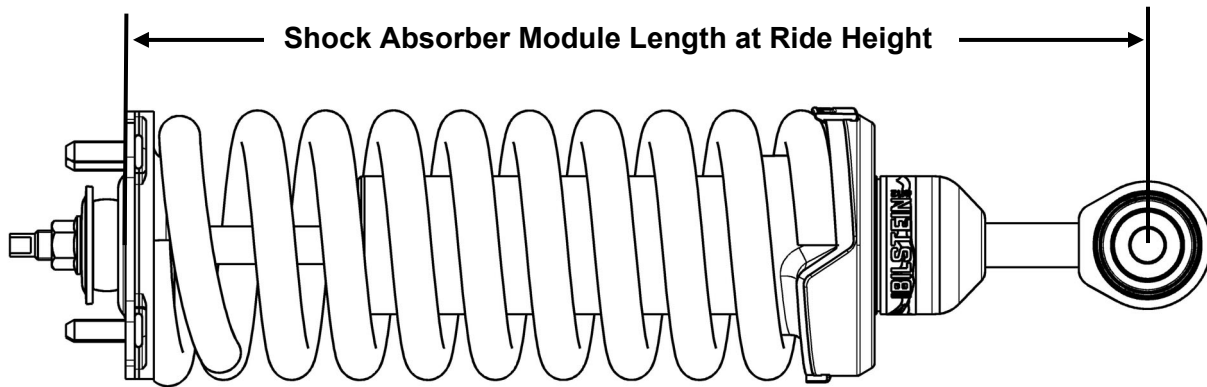

**Figure 2**

# E-WM05-0000070 MOUNTING INSTRUCTION



On all **i-FORCE MAX V6 Hybrid** '22+ Tundra models, it is recommended that the **driver side circlip** is installed in the same position as the **passenger side circlip**.

For example, to achieve the highest lift setting of 2.2" on a **Tundra 4WD, i-FORCE MAX V6 Hybrid, CrewMax, 5.5' or 6.5' bed** the circlips should be installed as follows:

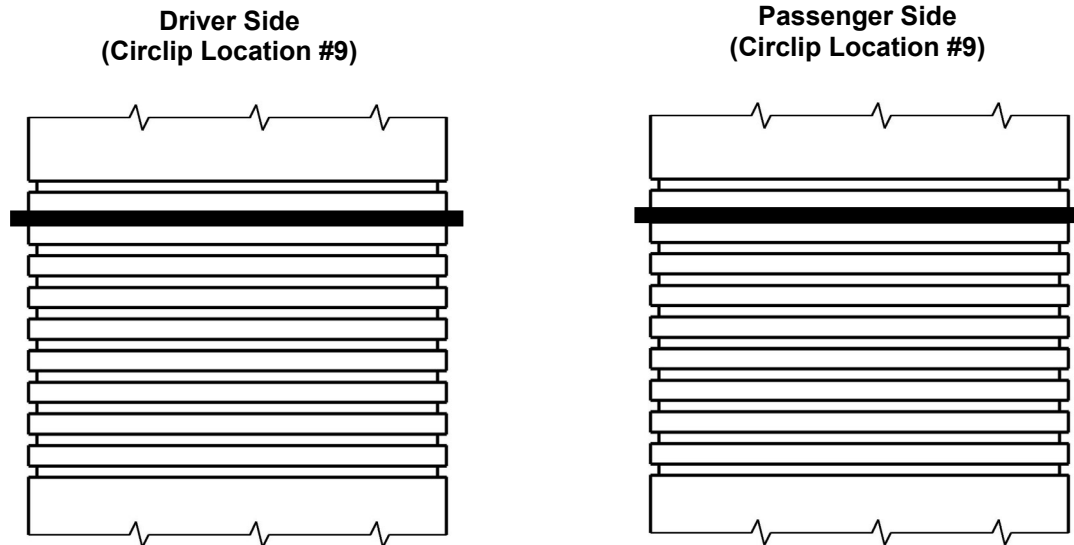

On all **i-FORCE V6** '22+ Tundra models, it is recommended that the **driver side circlip** is installed one position higher than the **passenger side circlip**.

For example, to achieve the highest lift setting of 2.2" on a **Tundra 4WD, i-FORCE V6, CrewMax, 5.5' or 6.5' bed** the circlips should be installed as follows:

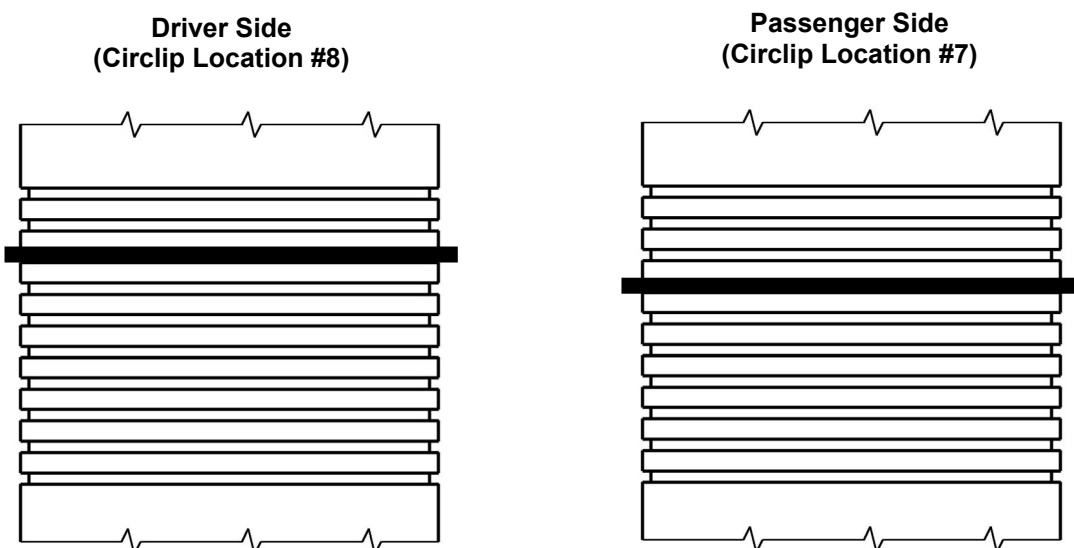

E-WM05-0000070  
MOUNTING INSTRUCTION



Bill of Materials (1 per Shock)		
Item #	Part Description	Quantity
1	Flanged Locknut, M14x1.5	1
2	Washer, 17.8mm ID	2
3	Bushing	1
4	Sleeve, 14mm ID, 40.5mm Length	1
5	Rod Adapter, 14/18mm	1
6	Spring Seat	1
7	Spring Isolator, Lower	1

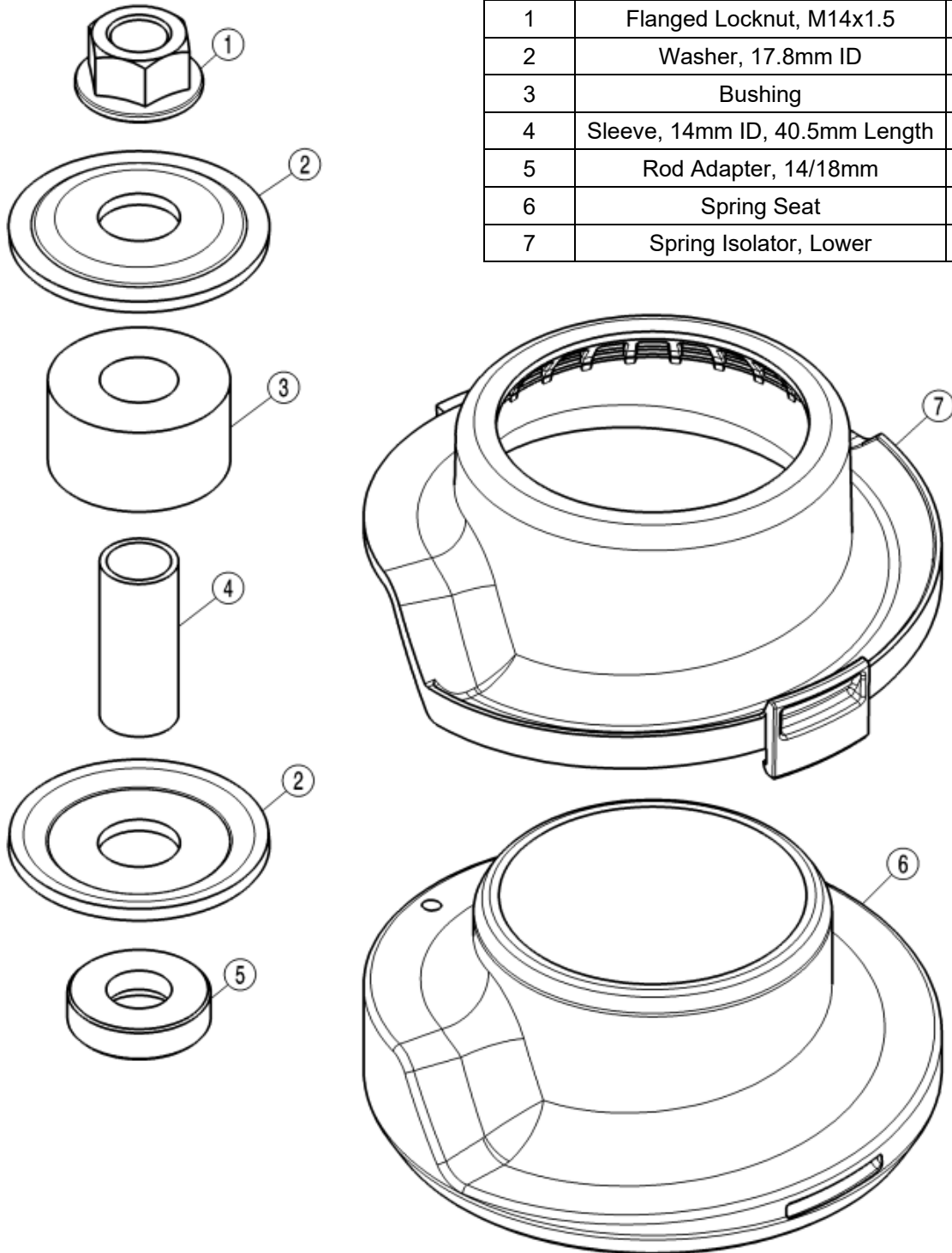

Figure 3

**Instructions for disassembly of OE shock absorber module:**

- A. Remove the existing shock and spring unit from the vehicle following all procedures in the vehicle manufacturer's service manual.
- B. Note the clocking of the lower mount bushing relative to the studs on the upper mount (important for reassembly).
- C. Using an appropriate spring compressor, compress the spring until it can be rotated freely by hand. Then, disassemble the shock and spring unit.

**Instructions for assembly of B8 6112 shock absorber module:**

- D. Select desired lift height by seating the circlip in the appropriate circlip location (see Figure 1 on page 2 and the lift height tables on page 3).
- E. Install the supplied spring seat onto the shock body as shown. Ensure that the groove inside the spring seat fits over the circlip on the shock body (see Figure 1, DETAIL A on page 2). Improper installation will cause permanent damage to the shock.

**[Refer to Figure 5 on page 9 for steps F-M]**

- F. Install the supplied spring seat isolator as shown.
- G. Install the supplied rod adapter (counter bore side down) and the supplied sleeve onto the stem of the rod as shown.
- H. Install one of the supplied washers (concave side up) onto the stem of the rod as shown.
- I. Using an appropriate spring compressor, compress the supplied coil spring enough to safely assemble it with the new Bilstein shock.
- J. Verify OE lower bushing is still glued underneath OE upper mount. Then place OE upper mount (top mount plate and spring isolator) onto the top of the spring and install the Bilstein unit into the spring up through the center of the OE upper mount.
- K. Install the supplied bushing onto the stem of the rod and over the sleeve. Some force will have to be applied to push it over the sleeve.
- L. Install the second supplied washer (concave side down) onto the stem of the rod as shown.
- M. Install the provided new locknut and tighten to 65 Nm (48 lb·ft). Be sure to keep the top washer centered under the nut while it's being torqued to ensure it seats around the sleeve. Use an 8mm wrench or crescent wrench to keep the piston rod from rotating while torquing the locknut. Refer to the dimension in Figure 4 below to verify the upper washer seats around the sleeve once tightened.

**\*\*\*\*DO NOT USE AN IMPACT WRENCH TO TIGHTEN THE LOCKNUT!\*\*\*\***

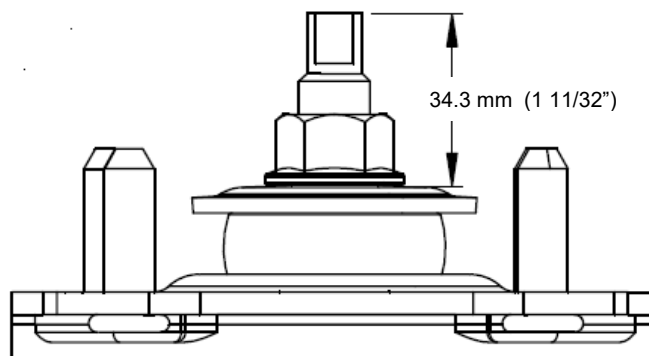
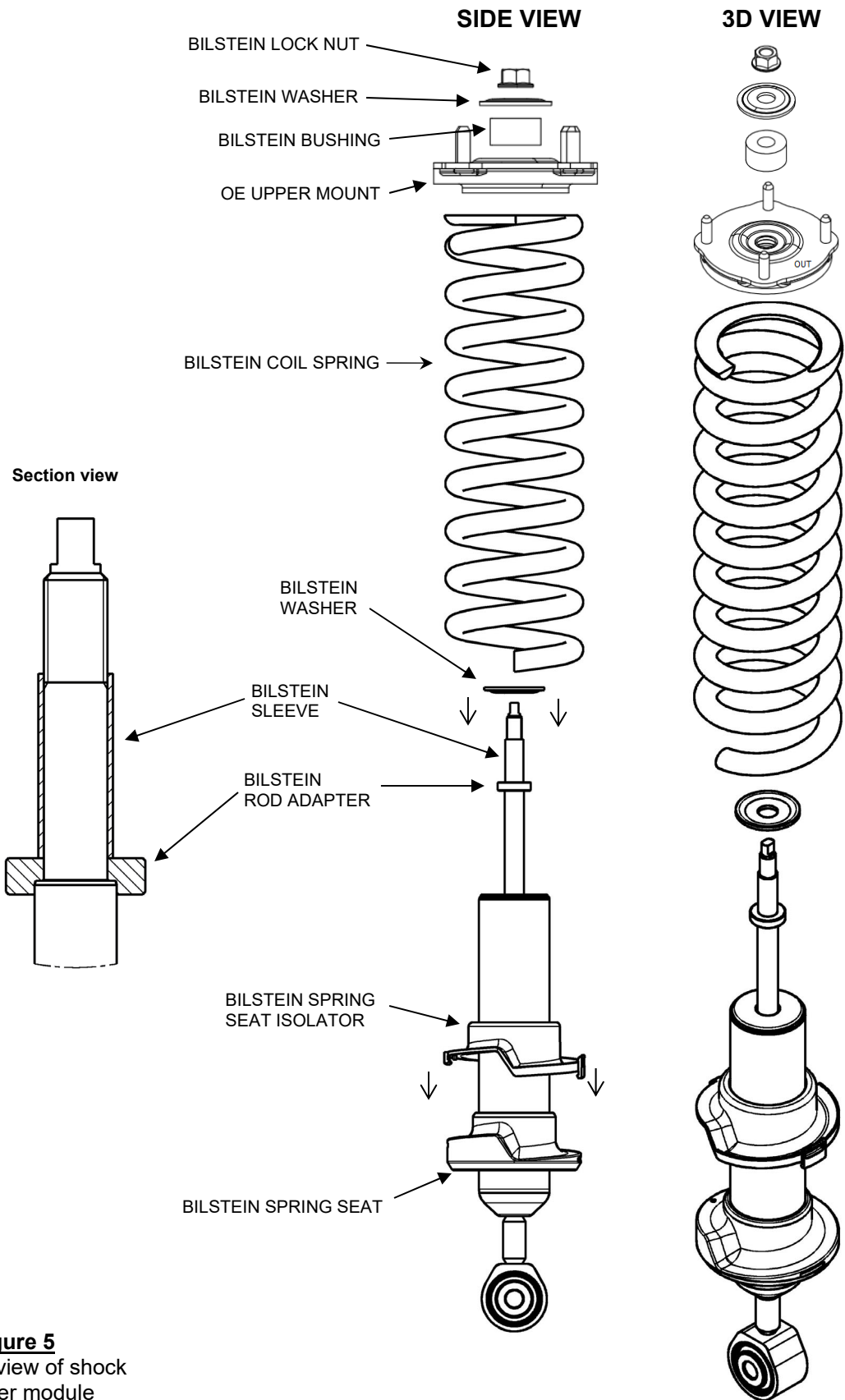

**Figure 4**



**[Refer to Figure 6 on page 10 for step N]**

- N. Rotate the shock so that the lower mount is aligned with the OE upper mount studs as noted in step B. Rotate the spring so the upper end coil is positioned 90 degrees clockwise from the "OUT" arrow on the OE upper mount (when looking down at the OE upper mount). Rotate the lower spring seat/isolator so they are indexed with the lower spring pigtail end.
- O. Slowly release the spring compressor while ensuring everything listed in the previous step remains aligned. Some spring bow before installation on the vehicle is normal.
- P. Install the shock absorber module assembly on to the vehicle and tighten all fasteners to vehicle manufacturer's specifications.
- Q. Check wheel alignment and adjust to the vehicle manufacturer's specifications. This completes the installation.



**Figure 5**  
Exploded view of shock absorber module

