



INSTALLATION INSTRUCTIONS

PART # RN-DGRAM-79

CUTLASS RUNNING BOARDS

02-08 DODGE RAM 1500 QUAD CAB

03-09 RAM 2500-3500 QUAD CAB

**CUTLASS RUNNING BOARDS
02-08 DODGE RAM 1500 QUAD CAB
03-09 RAM 2500-3500 QUAD CAB**

PARTS LIST:

1	Driver/Left Sidebar	4	10mm x 35mm Bolt Plates
1	Passenger/Right Sidebar	4	12-1.75mm x 120mm Gr.10.9 Hex Bolts
1	Driver/Left Front Mounting Bracket	4	12mm x 32mm OD x 3mm Flat Washers
1	Passenger/Right Front Mounting Bracket	4	12mm Lock Washers
1	Driver/Left Rear Mounting Bracket	4	10-1.5mm x 30mm Hex Bolts
1	Passenger/Right Rear Mounting Bracket	12	10mm x 30mm OD x 2.5mm Flat Washers
1	Driver/Left Front Support Bracket	8	10mm Lock Washers
1	Passenger/Right Front Support Bracket	8	10mm Hex Nuts
1	Driver/Left Rear Support Bracket	8	8-1.25mm x 20mm T-Bolts
1	Passenger/Right Rear Support Bracket	8	8mm Lock Washers
4	12mm x 44mm OD x 4mm Spacers	8	8mm x 24mm OD x 2mm Flat Washers
4	10mm Plastic Retainers	8	8mm Hex Nuts

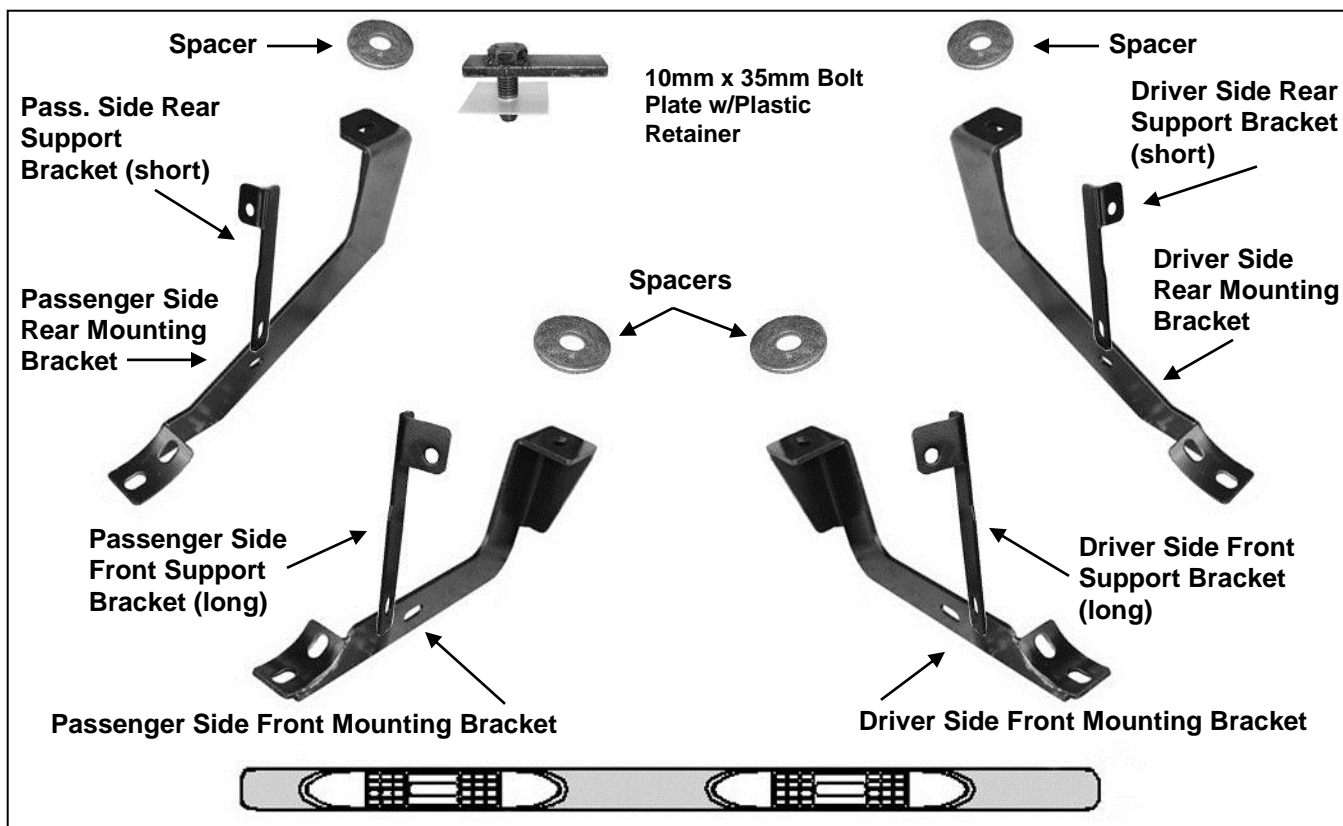

PROCEDURE:

- 1. REMOVE CONTENTS FROM BOX. VERIFY ALL PARTS ARE PRESENT. READ INSTRUCTIONS CAREFULLY BEFORE STARTING INSTALLATION.**
- Starting toward the front of the driver side, locate and remove the factory front body mount bolt with attached washer, **(Figure 1)**. Remove but do not discard the factory rubber bushing from the factory bolt. Next, remove the sealing tape covering the forward hole in the inner body panel, **(Figure 1)**.
- Thread (1) Plastic Retainer part way onto (1) 10mm x 35mm Bolt Plate, **(Figure 2)**. Insert the Bolt Plate into the factory hole on the rocker panel. Hold the Bolt Plate in place with one hand and thread the Plastic Retainer down against the sheetmetal to hold the Bolt Plate in place, **(Figure 3)**. **IMPORTANT:** The Plastic Retainer is designed to prevent the Bolt Plate from falling into the body panel and to aid in Bracket installation.

CUTLASS RUNNING BOARDS
02-08 DODGE RAM 1500 QUAD CAB
03-09 RAM 2500-3500 QUAD CAB

4. Locate the driver side front Support Bracket , **(Figure 4)**, and attach it to the Bolt Plate with (1) 10mm Flat Washer, (1) 10mm Lock Washer and (1) 10mm Hex Nut, **(Figure 6)**. **NOTE:** Place Support Bracket against the front facing side of the Mounting Bracket with the bent tab facing towards the **front** of the vehicle. Snug but do not tighten hardware at this time.
5. Select the driver side front Mounting Bracket. Insert (1) 12-1.75mm x 120mm Hex Bolt with (1) 12mm ID x 32mm OD x 3mm Flat Washer and (1) 12mm Lock Washer through the Mounting Bracket. Place (1) Spacer Plate onto the 12mm Hex Bolt then slide the rubber bushing onto the Hex Bolt, **(Figure 5)**. Make sure that the Spacer Plate is between the Mounting Bracket and the factory rubber bushing, **(Figure 6)**. Attach the front Mounting Bracket, (with hardware, factory washer and rubber bushing), up to the bottom of the body mount, **(Figure 6)**. Snug but do not tighten hardware at this time.
IMPORTANT: On 05 and newer model years, the large washer on the factory body mount bolt is removable, (do not discard-must reinstall), and the bolt is long enough to go through the Mounting Bracket and properly thread into the body mount. It is the installer's responsibility to check length and to determine whether to use the factory or replacement hex bolt.
6. Attach the lower end of the front Support Bracket to the Mounting Bracket using (1) 10mm x 30mm Hex Bolt, (2) 10mm Flat Washers, (1) 10mm Lock Washer and (1) 10mm Hex Nut, **(Figure 6)**. Do not tighten hardware at this time.
7. Next, move to the rear body mount at the back of the cab. Remove the body mount bolt and sealing tape covering the hole in the inner body panel as described in **Step 2**.
8. Repeat **Step 3** to install (1) Bolt Plate in the inner body panel. Select the driver side rear Support Bracket, **(Figure 4)**. Attach the Support Bracket to the Bolt Plate with (1) 10mm Flat Washer, (1) 10mm Lock Washer and (1) 10mm Hex Nut, **(Figure 7)**.
9. Select the driver side rear Mounting Bracket. Repeat **Step 5** to install the rear Bracket, **(Figure 7)**.
NOTE: Place Support Bracket against the front facing side of the Mounting Bracket with the bent tab facing towards the **rear** of the vehicle. Repeat **Step 6** to attach the lower end of the Support Bracket to the Mounting Bracket, **(Figure 8)**. Snug but do not tighten hardware at this time
10. Select the driver/left sidebar. Locate the opening in the end of the channels in the bottom of the Sidebar. Slide (2) 8mm T-Bolts into each channel, **(Figure 9)**. Carefully position the Driver Sidebar onto the (2) Mounting Brackets. Lift the Sidebar up and slide the T-Bolts along the sidebar to match up with the Brackets. **IMPORTANT:** Do not slide, (front to back or rotate), the Sidebar on the Brackets or damage to the finish on the Sidebar may result.
11. Line up the front of the Sidebar approximately 2" back, (or locate as desired), from the front wheel opening. Attach the Sidebar to the Mounting Brackets with (4) 8mm Flat Washers, (4) 8mm Lock Washers and (4) 8mm Hex Nuts, **(Figures 9 & 10)**. Do not tighten hardware at this time.
12. Level and adjust the Sidebar and tighten all hardware.
13. Repeat **Steps 2—12** for the passenger/right sidebar installation.
14. Do periodic inspections to the installation to make sure that all hardware is secure and tight.

To protect your investment, wax this product after installing. Regular waxing is recommended to add a protective layer over the finish. Do not use any type of polish or wax that may contain abrasives that could damage the finish.

For stainless steel: Aluminum polish may be used to polish small scratches and scuffs on the finish. Mild soap may be used also to clean the Sidebar.

For gloss black finishes: Mild soap may be used to clean the Sidebar.

**CUTLASS RUNNING BOARDS
02-08 DODGE RAM 1500 QUAD CAB
03-09 RAM 2500-3500 QUAD CAB**

Driver Side Installation Pictured

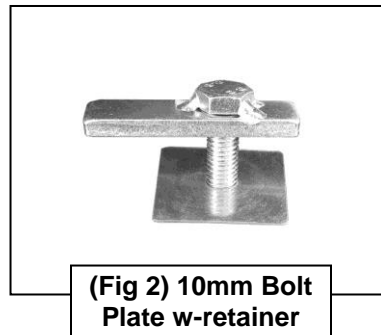
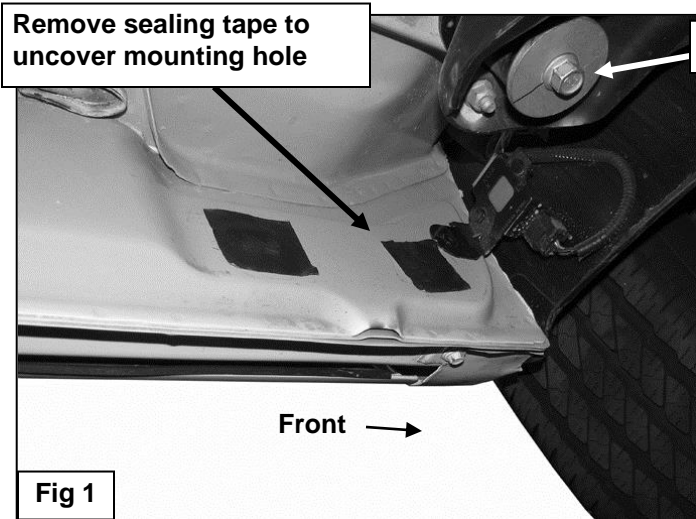
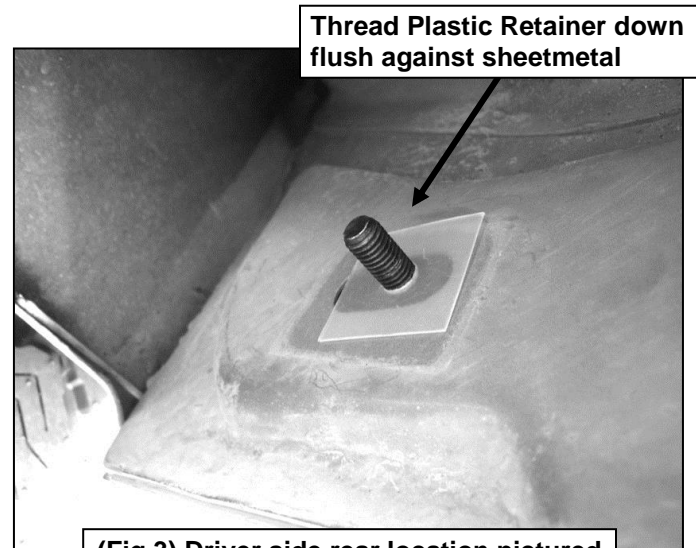

Fig 1

(Fig 2) 10mm Bolt Plate w-retainer



(Fig 3) Driver side rear location pictured

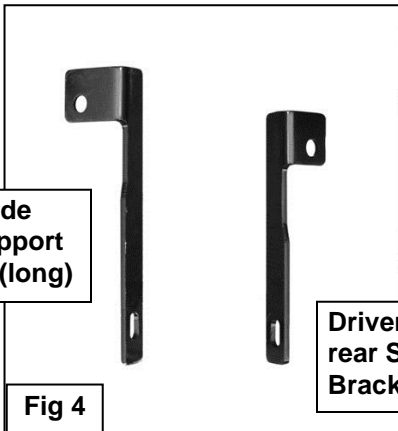
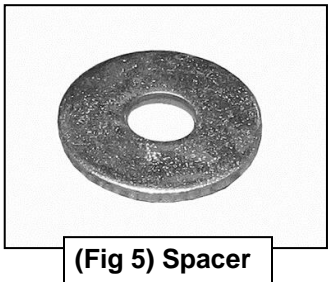

Fig 4

- 10mm x 30mm Hex Bolt
- (2) 10mm Flat Washers
- 10mm Lock Washer
- 10mm Hex Nut

- 10mm x 35mm Bolt Plate
- 10mm Flat Washer
- 10mm Lock Washer
- 10mm Hex Nut



(Fig 5) Spacer

IMPORTANT: Insert (1) Steel Spacer between each front and rear Mounting Bracket and factory rubber bushing (driver side front Mounting Bracket pictured)

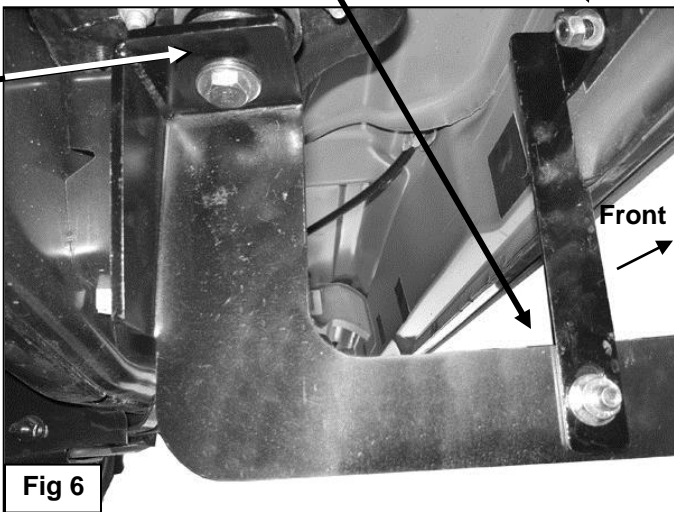

Fig 6

**CUTLASS RUNNING BOARDS
02-08 DODGE RAM 1500 QUAD CAB
03-09 RAM 2500-3500 QUAD CAB**

Driver Side Installation Pictured

10mm x 35mm Bolt Plate
10mm Flat Washer
10mm Lock Washer
10mm Hex Nut

Factory body bolt

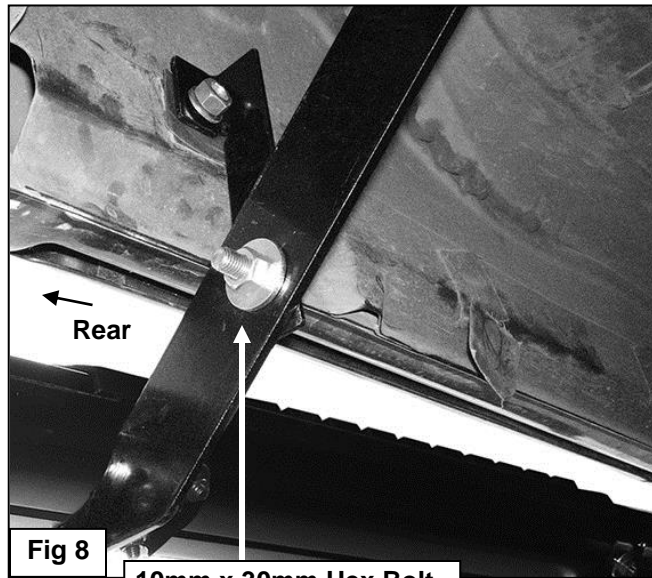
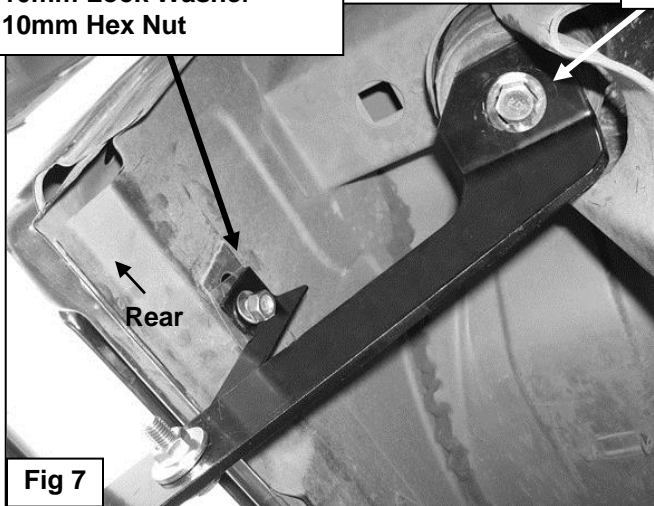

10mm x 30mm Hex Bolt
(2) 10mm Flat Washers
10mm Lock Washer
10mm Hex Nut

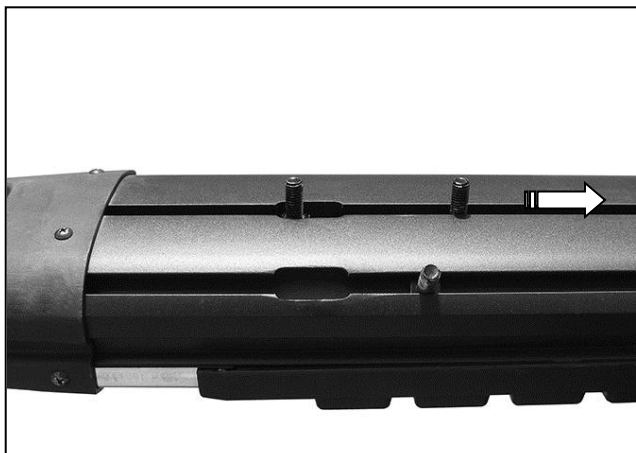

(Fig 9) Slide (2) 8mm T-Bolts into each channel

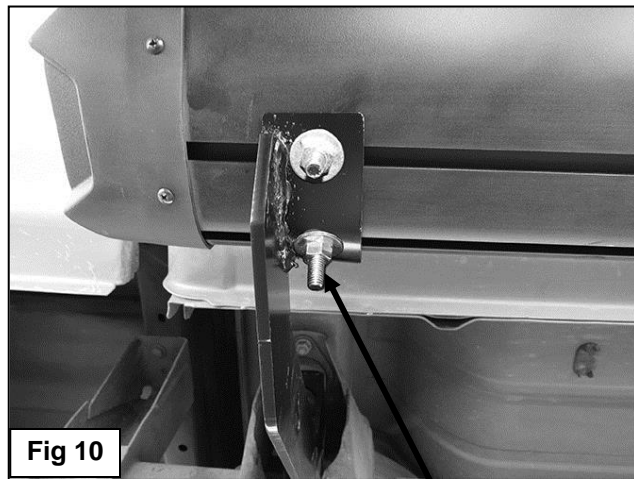

(2) 8mm Flat Washers
(2) 8mm Lock Washers
(2) 8mm Hex Nuts

