



INSTALLATION INSTRUCTIONS

PART#:17TS26MSS\17TS26MA

MODULAR GRILL GUARD FOR TOYOTA SEQUOIA 2/4WD 01-04

MODULAR GRILL GUARD FOR TOYOTA SEQUOIA 2/4WD 01-04

QTY	DESCRIPTION
1	guard, center section
1	brush guard, left side
1	brush guard, right side
1	wire guard insert, left side
1	wire guard insert, right side
1	lower support bracket-left
1	lower support bracket-right
1	hardware kit

NOTE: Please read this information before assembling. Check components received with components listed above. **NO DRILLING REQUIRED.** Complete step by step instruction sheets will be found on the following pages.

- 1st. Stage, mounting of guard to vehicle.
- 2nd. stage, attaching brush guards to center section.
- 3rd . stage, attaching wire head light guards.

IMPORTANT: To obtain correct installation, we recommend you to follow these step by step instructions carefully.

Illustrations are for reference only, styles vary with application. Please review the instruction sheet before proceeding to assemble product.

Please take care when assembling and installing this product to protect the finish and your investment. To protect your investment, wax this product after installing. Regular waxing is recommended. Do not use any type of polish or wax that contains abrasive that could damage the finish.

INSTALLATION INSTRUCTIONS

1ST STAGE

PARTS LIST

1-FORNT BAR	6-M12 × 30 HEX BOLTS	6-M6X20 SCREWS
2-TOP BRACKETS	12- φ 12 FLAT WASHERS	6-M6 HEX NYLOK NUTS
2-FRAME BRACKETS	6-M12 HEX NUTS	6- φ 6 FLAT WASHERS

INSTALLING THE FRAME MOUNTING BRACKETS

- 1) OPEN VEHICLE FRONT HOOD TO GET TO THE EXISTING HOOKS (LOCATED TOP LEFT AND TOP RIGTH.) THE BOLT PATTERN ON THE TOP BRACKETS WILL BE POSITIONED IN MANNER SHOWN IN ILLUSTRATION (PASSENGER SIDE SHOWN) AT THE TOP BRACKETS USING THE M8X20 SCREWS. HANDS TIGHTEN AS YOU MAY HAVE TO MOVE BRACKETS AROUND.

INSTALLING THE FRAME BRACKETS

- 2) REMOVE FACTORY TOW HOOKS (BUT DO NOT DISCARD THE FACTORY BOLTS) THE BOLT PATTERN ON THE FRAME MOUNTING BRACKETS WILL BE POSITIONED IN MANNER SHOWN IN ILLUSTRATION (PASSENGER SHOWN) ATTACH FRAME BRACKETS USING THE FACTORY BOLTS.

INSTALLING THE FRONT BAR

- 3) LINE UP THE THREE HOLES ON THE LOWER PORTION OF FRONT BAR WITH THE THREE HOLES ON THE FRAME BRACKETS (OUTER EDGE) USING THE M12 × 30 HEX BOLT, M12 HEX NUT AND M12 FLAT WASHERS TO FASTEN THE FRONT BAR TO THE FRAME BRACKETS. TOP PORTION OF THE FRONT BAR WILL LINE UP WITH THE HOLES ON THE CENTER BRUSH GUARD PLATE (UNDER) USING THE M8X20 SCREWS, M8 HEX NYLOK NUTS AND φ 8 FLAT WASHERS TO FASTEN THE FRONT BAR.
- 4) REMOVE THE REVETS LOCATED UNDERNEATH THE VEHICLE IN ORDER TO INSTALL THE L-SUPPORT BRACKETS, ATTACH L-SUPPORT BRACKETS USING THE M8X20 SCREWS, M8 HEX NYLOK NUTS AND M12 × 30 HEX BOLTS, φ 12 FLAT WASHERS AND M12 HEX NUT (USE M12X30 HEX BOLT ATTACHING FRAME BRACKET TO THE FRONT BAR)
- 5) ONCE THE FRONT BAR IS ATTACHING TO ALL MOUNTING BRACKETS ALIGN THE LEFT AND RIGTH SIDE OF THE FRONT BAR TO THE BUMPER AND TIGHTEN ALL FASTENERS

PASSENGER SIDE SHOWN

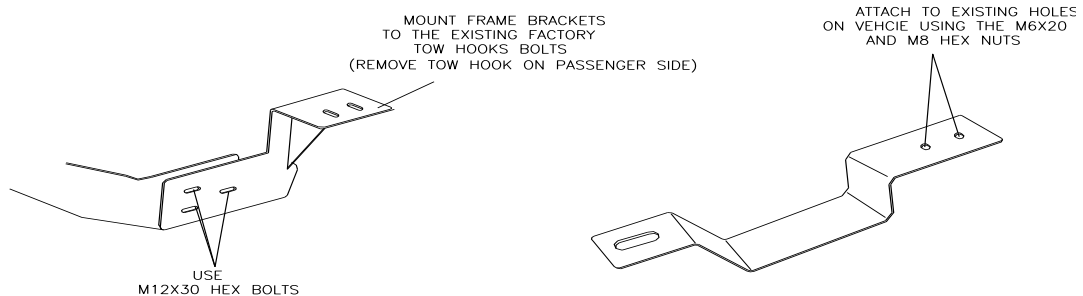

INSTALLATION INSTRUCTION

2nd STAGE

Step One: Locate hardware. Check contents with the hardware listed below.

QTY	DESCRIPTION
6	M8-1.25 x 20 button head bolts, stainless steel
6	M8-1.25 acorn nuts, stainless steel
12	M8 flat washers, stainless steel
2	rubber gaskets

Step Two: Securing brush guards to center section. Locate the following item's listed below.

QTY	DESCRIPTION
1	brush guard, left side
1	brush guard, right side

Assemble the brush guards to the center section of the guard as shown in illustration below. Use the hardware from step one to secure the parts together. Be sure to fully tighten all hardware at this time. Proceed ahead to stage four of the instruction sheet.

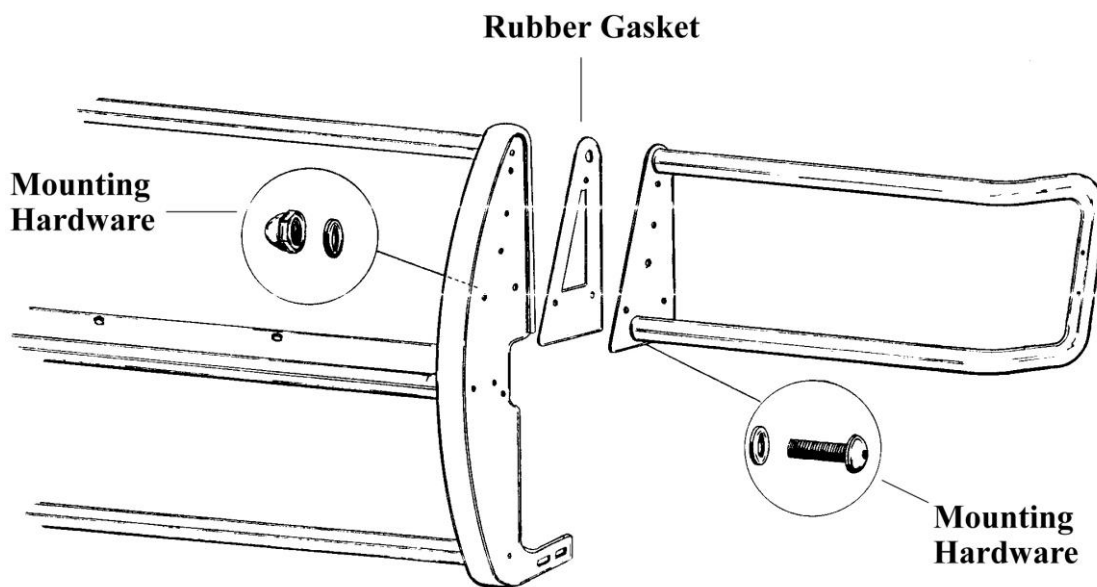

INSTALLATION INSTRUCTION

3rd STAGE

Step One: Locate hardware. Check contents with the hardware listed below.

QTY	DESCRIPTION
8	M6-1.00 x 25mm button head bolts, stainless steel
4	M6-1.00 acorn nuts, stainless steel
12	M6 flat washers, stainless steel
4	rubber gaskets

Step Two: Securing wire insert to brush guards. Locate the following item's listed below.

QTY	DESCRIPTION
2	wire guard insert, left & right side

Attach one rubber gasket to each end of the wire guard. Peel the paper backing off the rubber gasket. Place the gasket on the end of the bracket and press firmly till the gasket is secured in place.

Position the wire insert on the driver's side of the vehicle. Align the two holes in the bracket with the two holes in the brush guard as shown in illustration below. Using the hardware listed in step one, secure the wire insert to the brush guard. Be sure to fasten both ends before fully tightening hardware. Repeat this procedure on the opposite side of the vehicle. Be sure to use all hardware supplied and tighten all bolts.

