

INSTALLATION INSTRUCTIONS

ARMOUR FRONT BUMPER

2018 FORD F150(Incl. EcoBoost engine model)

ARMOUR FRONT BUMPER FOR
2018 FORD F150 (Incl. EcoBoost engine model)
PART#AFB-F115-18

PARTS LIST:

1	Front Bumper Assembly	6	10mm Lock Washer
1	Driver/left Frame Bracket	6	10mm Hex Nut
1	Passenger/right Frame Bracket	2	8-1.25mm x 25mm Hex Bolts
1	Driver/left "L" Bracket (center LED light)	2	8-1.25mm x 16mm Hex Bolts (LED light bar)
1	Passenger/right "L" Bracket (center LED light)	6	8mm x 24mm Flat Washers
1	License Plate Bracket	4	8mm Lock Washers
2	Plastic Plugs for license plate mount	2	8mm Hex Nuts
2	12-1.75mm x 35mm Hex Bolt	2	6mm x 20mm Button Head Bolts
4	12mm x 32mm x 3mm Flat Washer	4	6mm x 18mm x 1.6 Flat Washers
2	12mm Nylon Hex Nut	2	6mm Nylon Lock Nuts
6	10-1.5mm x 35mm Hex Bolt	1	Wrench
12	10mm x 27mm x 3mm Flat Washer	10	Nylon Wire Ties

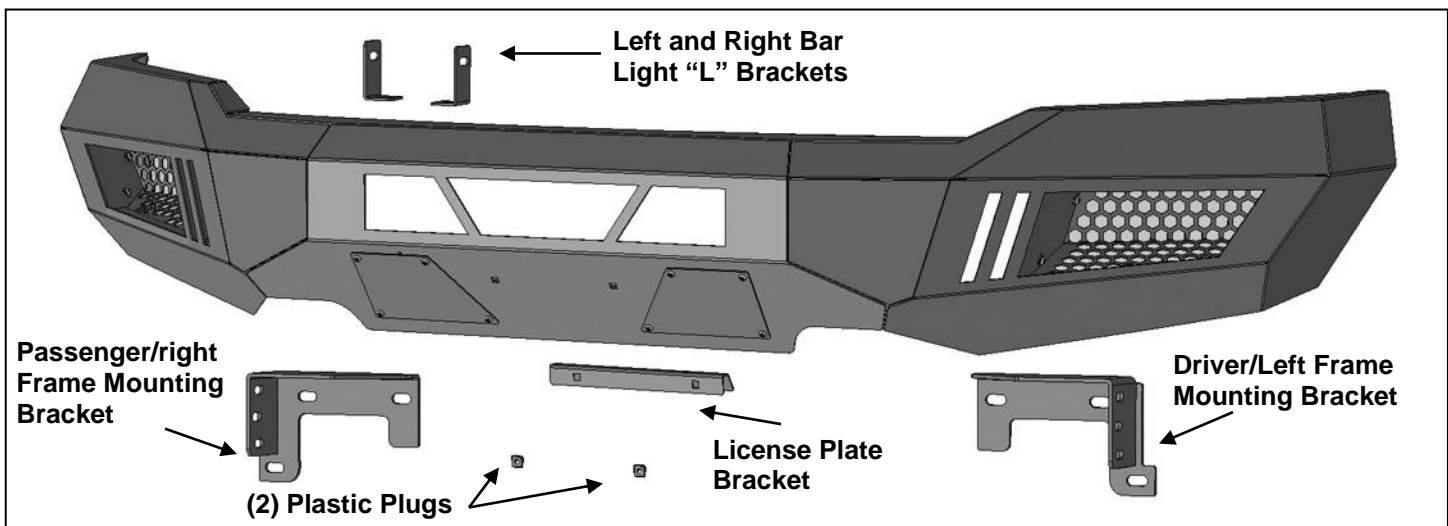

PROCEDURE:

REMOVE CONTENTS FROM BOX. VERIFY ALL PARTS ARE PRESENT. READ INSTRUCTIONS CAREFULLY BEFORE STARTING INSTALLATION. BUMPER IS HEAVY, ASSISTANCE IS HIGHLY RECOMMENDED TO AVOID POSSIBLE INJURY OR DAMAGE TO THE VEHICLE.

1. On models with factory fog lights, unplug wiring harness leading to the bumper. Move harness away from bumper. From behind the bumper, remove factory hex nuts attaching the bottom of the bumper bracket to the frame bracket, **(Figure 1)**.
2. Remove the license plate and bracket. Next, remove both plastic bumper pads from the bumper, **(Figure 2)**. Pad is held in place with metal clips. Release the clips from back of bumper and pull the pad straight out to remove bumper pad. **NOTE:** It may be easier to access bumper hardware with air dam removed from bumper.
3. Place blocks or jack stands under the front bumper to support it during mounting bolt removal. Once the bumper has been safely supported, through the opening in the front of the bumper, remove the factory hex nuts and remove the bumper, **(Figures 2 & 3)**. **WARNING!** Assistance is required to hold the bumper in place during bolt removal to prevent the bumper from falling.
4. Remove the plastic seals around the tow hooks.
5. Select the driver/left Frame Bracket, **(Figure 4)**. Reuse the (2) factory hex nuts to attach the Frame Bracket to the end of the frame. Use (1) 12mm x 35mm Hex Bolt, (2) 12mm Flat Washers and (1) 12mm Nylon Lock Nut to attach the remaining mounting hole in the Bracket

ARMOUR FRONT BUMPER
2018 FORD F150(Incl. EcoBoost engine model)

to the lower mounting hole in the end of the frame. Do not fully tighten hardware at this time. Repeat to install the passenger/right Frame Mounting Bracket, **(Figures 4 & 5)**.

6. If front license plate is required, attach the License Plate Bracket to the holes in the bumper with the included (2) 6mm x 20mm Button Head Screws, (4) 6mm Flat Washers and (2) 6mm Nylon Lock Nuts, **(Figure 6)**. Insert (2) Plastic Plugs into the square holes in the Bracket. Reuse the factory screws to attach the license plate to the plastic plugs, **(Figure 6)**.
7. On EcoBoost models, remove the (2) covers from the bottom of the LD-1 Bumper, **(Figure 7)**.
8. **Center LED light installation** as supplied with bumper or sold separately.
 - a. Select the L/R “L” Brackets, **(Figure 8)**. Attach the Brackets to the top of the (2) mounting tabs welded onto the back of the bumper with the included 8mm x 25mm Hex Bolts, (4) 8mm Flat Washers, (2) 8mm Lock Washers and (2) 8mm Hex Nuts. Leave loose at this time.
 - b. Attach the LED light assembly to the “L” Brackets with the included (2) 8mm x 16mm Hex Bolts, (2) 8mm Lock Washers and (2) 8mm Flat Washers. Do not fully tighten hardware at this time. **IMPORTANT:** “L” Brackets are designed for 8mm light mounting hardware only. Modify “L” Brackets if necessary or use brackets supplied by your light manufacturer if possible to install hardware larger than 8mm.
 - c. Follow light manufacturer’s instructions to properly wire the light.
9. **LED light installation at ends of bumper** (sold separately).
 - a. Insert light into opening and up to mounting slots. Check for clearance between front and back of light. If necessary, remove the screen from the the opening, **(Figure 9)**.
 - b. Follow the light manufacturer’s instructions to attach (1) light to the center slot or (2) lights to the inner and outer slots in the top of the light opening, **(Figure 10)**.
IMPORTANT: On two light systems, attach the flood light to the outer slot and the spot light to the inner slot.
 - c. Repeat the above steps for passenger side light installation.
 - d. Follow light manufacturer’s instructions to properly wire the light.
10. With assistance, position the Bumper Assembly up to the mounting flanges on the frame. Temporarily support the weight of the Bumper. **WARNING:** To avoid possible injury or damage to the vehicle, do not proceed until the bumper is fully and safely supported.
11. Attach the driver side mounting plate on the back of the bumper to the Mounting Bracket with the included (3) 10mm x 35mm Hex Bolts, (6) 10mm Flat Washers and (3) 10mm Nylon Lock Nuts, **(Figures 11 & 12)**. Repeat this Step to attach the passenger side of the Bumper to the Bracket. Do not fully tighten hardware at this time.
12. Level and adjust the bumper and fully tighten all hardware.
13. Do periodic inspections to the installation to make sure that all hardware is secure and tight.

To protect your investment, wax this product after installing. Regular waxing is recommended to add a protective layer over the finish. Do not use any type of polish or wax that may contain abrasives that could damage the finish. Mild soap may be used to clean the Bumper assembly.

ARMOUR FRONT BUMPER
2018 FORD F150(Incl. EcoBoost engine model)

Driver Side Installation Pictured

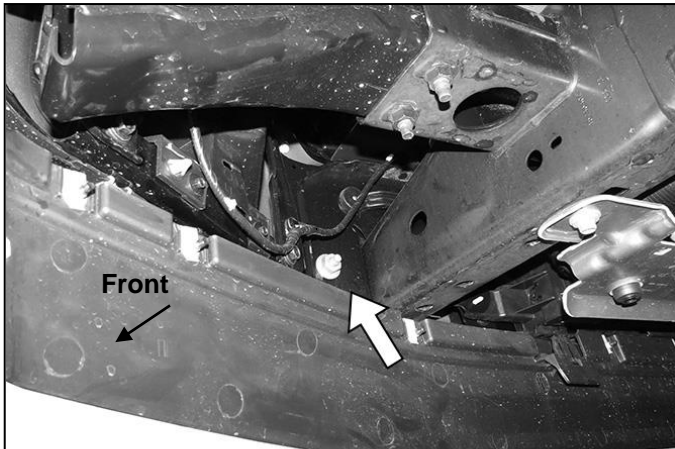

(Fig 1) Remove hex nut (arrow) and release wiring harness leading to bumper if equipped

WARNING! Do not remove bumper bolts unless the bumper is properly supported on blocks or stands or the bumper may fall.



(Fig 2) Remove license plate and plastic bumper pads from bumper (passenger/right side pictured)

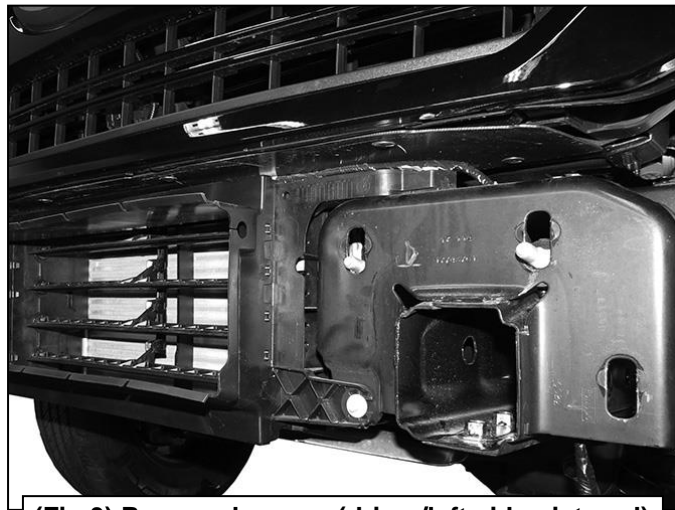

(Fig 3) Remove bumper (driver/left side pictured)

Reuse factory hex nuts

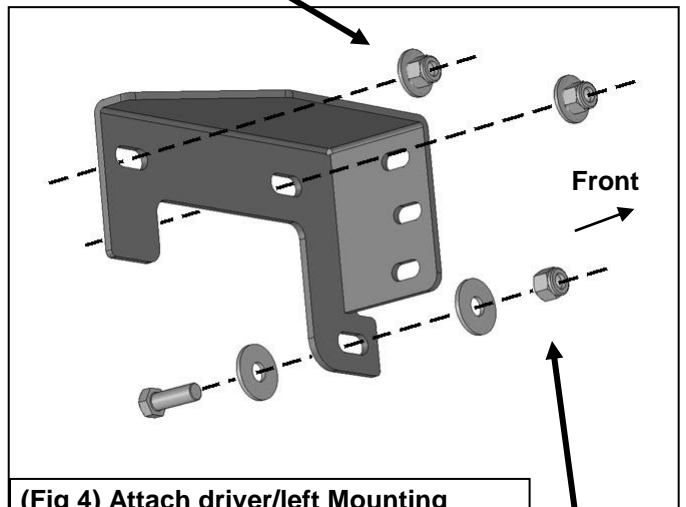

(Fig 4) Attach driver/left Mounting Bracket to end of frame

12mm x 35mm Hex Bolt
(2) 12mm Flat Washers
12mm Nylon Lock Nut



(Fig 5) Frame Mounting Brackets installed

**ARMOUR FRONT BUMPER
2018 FORD F150(Incl. EcoBoost engine model)**

Driver Side Installation Pictured

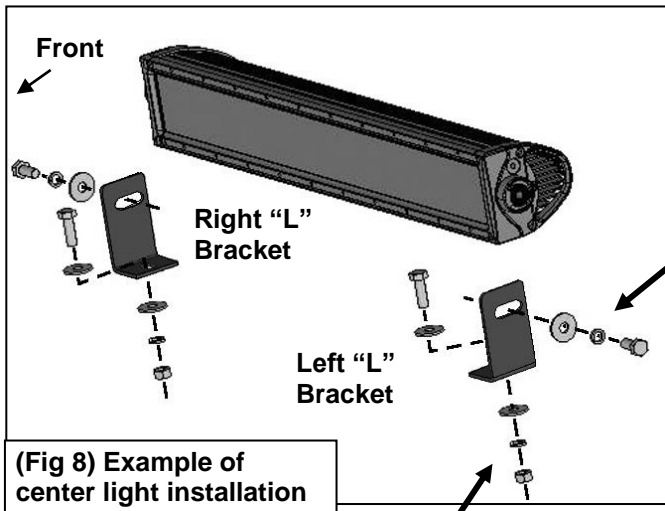
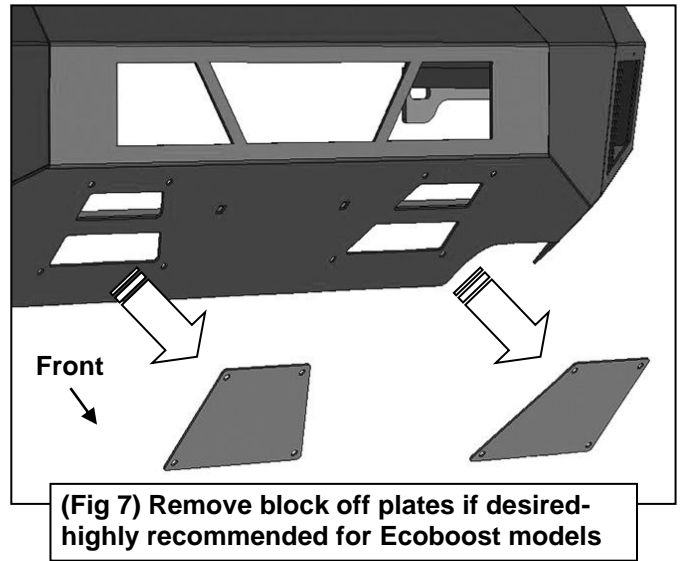
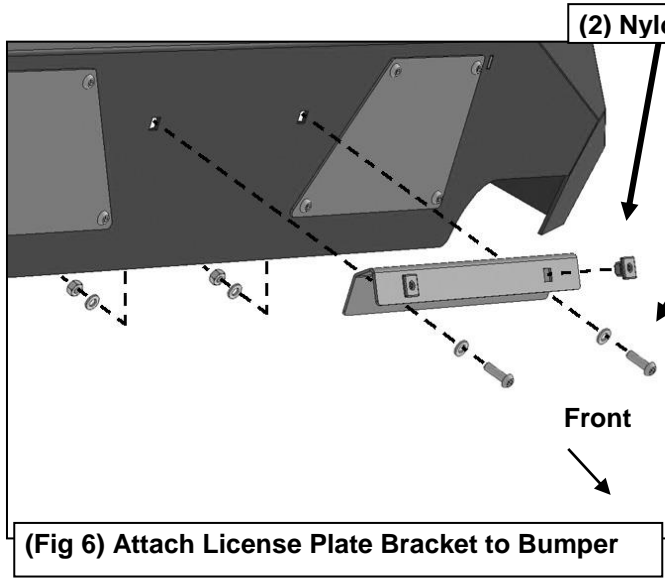

- (2) 8mm x 16mm Hex Bolts
- (2) 8mm Lock Washers
- (2) 8mm Flat Washers

- (2) 8mm x 25mm Hex Bolts
- (4) 8mm Flat Washers
- (2) 8mm Lock Washers
- (2) 8mm Hex Nuts

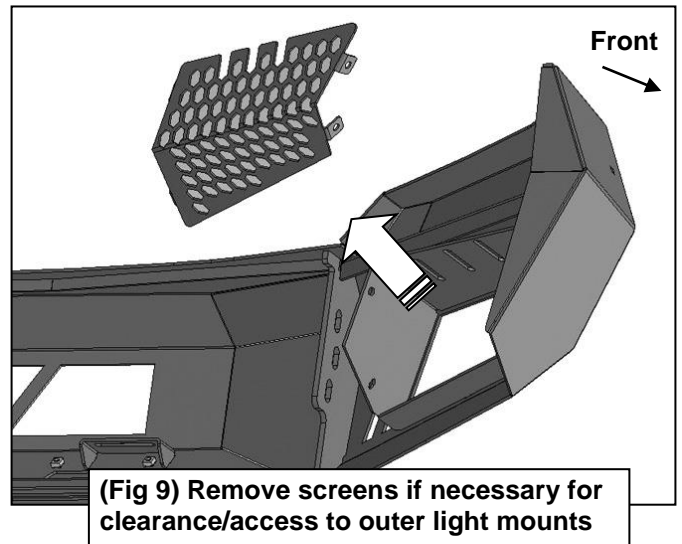

**ARMOUR FRONT BUMPER
2018 FORD F150(Incl. EcoBoost engine model)**

Driver Side Installation Pictured

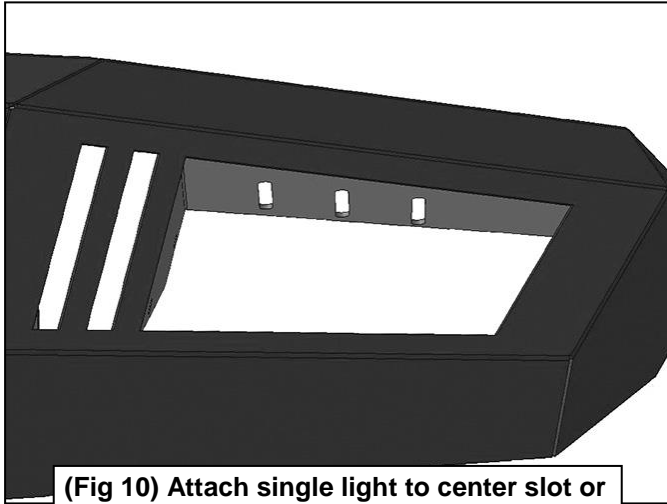

(Fig 10) Attach single light to center slot or use inner and outer slots for dual lights

- (3) 10mm x 35mm Hex Bolts**
- (6) 10mm Flat Washers**
- (3) 10mm Nylon Lock Nuts**

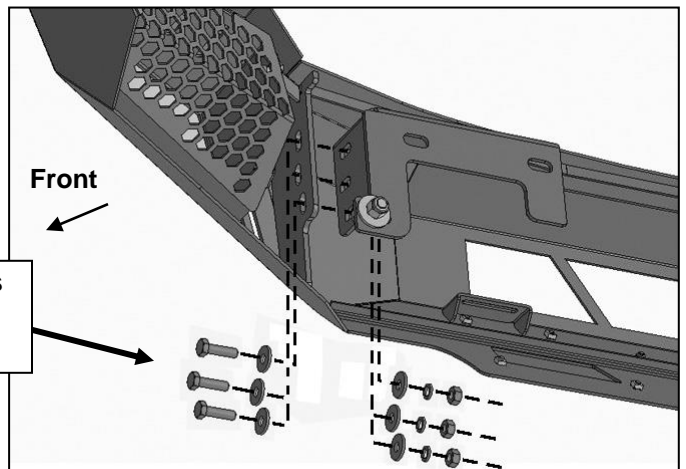

(Fig 11) Attach Bumper to Frame Mounting Bracket

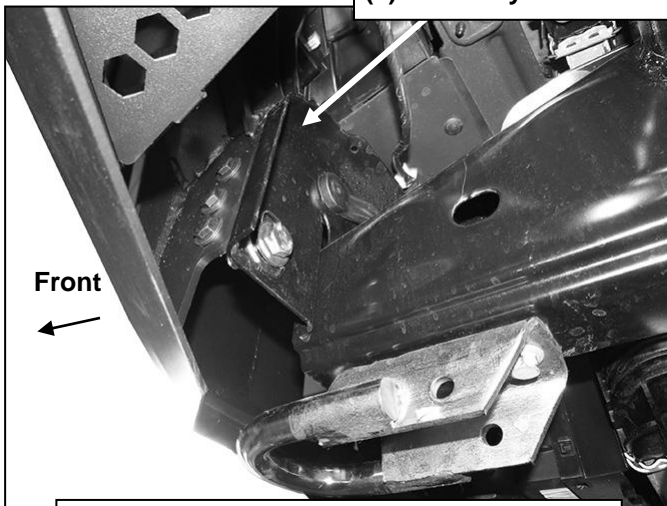

(Fig 12) Driver/left side of Bumper attached to Bracket (pictured from below)

