



TEL: 1-866-XANATOS

INSTALLATION INSTRUCTIONS

**LD-1 REAR BUMPER FOR
09-18 RAM 1500 (Incl. 19-20 Ram 1500 Classic)
10-20 RAM 2500/3500
PART#ARB-RA13**

PARTS LIST:

1	LD1 Rear Bumper Assembly	4	12-1.75mm x 40mm Hex Bolts
1	Step Hole Plug	4	12mm x 37mm x 3mm Flat Washers
1	Push in License Plate Light	4	12mm Lock Washers
2	Plastic Plugs for license plate mount	10	4mm x 10mm Button Head Bolts
4	Sensor Retaining Clips	4	4mm x 12mm x 1mm Flat Washers
4	15.5mm x 25mm x 2mm Foam Washers	2	4mm Lock Washers
4	Sensor Hole Plugs	2	4mm Hex Nuts
2	Dodge Wiring Harnesses	10	Nylon Cable Ties 200mm
1	Sensor Cover Kit	1	6mm Wrench
2	12mm Double Nut Plates	1	4mm Wrench

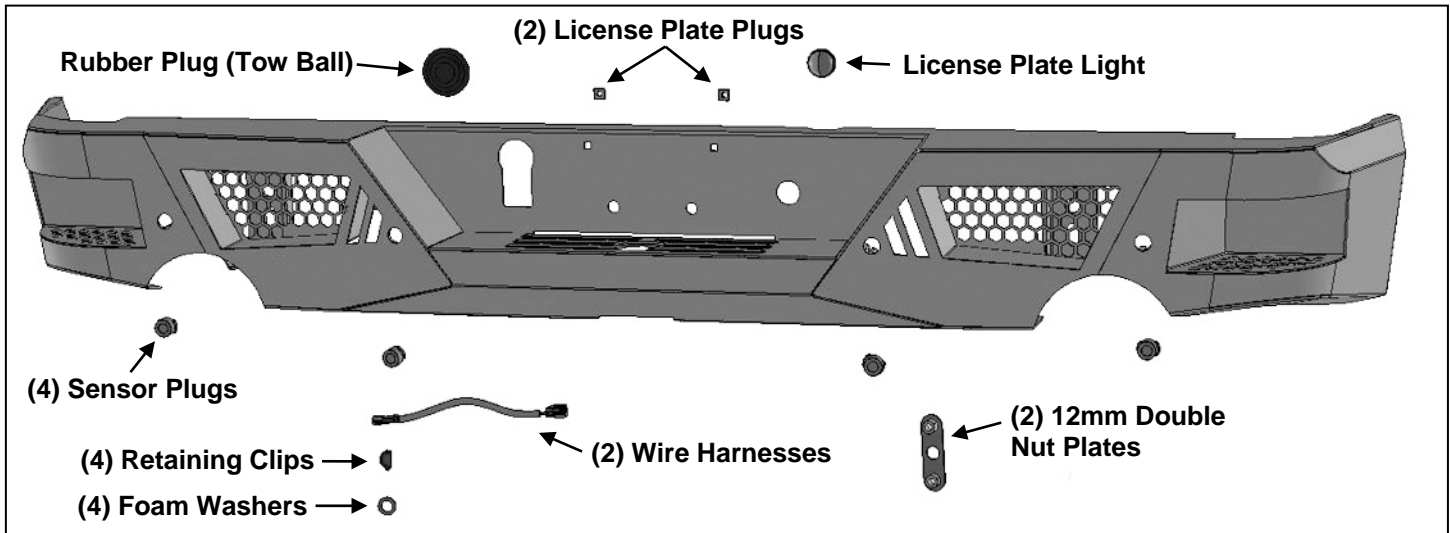

PROCEDURE:

REMOVE CONTENTS FROM BOX. VERIFY ALL PARTS ARE PRESENT. READ INSTRUCTIONS CAREFULLY BEFORE STARTING INSTALLATION. BUMPER IS HEAVY, ASSISTANCE IS HIGHLY RECOMMENDED TO AVOID POSSIBLE INJURY OR DAMAGE TO THE VEHICLE. ON MODELS WITH DUAL EXHAUST, ALLOW EXHAUST TO COMPLETELY COOL BEFORE STARTING INSTALLATION.

1. Start installation by unplugging the wiring harnesses leading to the rear bumper, (Figures 1 & 2). Move the wiring harnesses away from the bumper. Remove the outer tow harness plug, (Figure 3)
2. Remove the license plate. Remove the (2) hex bolts behind the license plate, (Figure 4).
3. Place blocks or jack stands under the bumper to support it during bumper bolt removal. Once the bumper has been safely supported, remove the (4) factory bumper bolts, (2 per side), and slide the bumper off of the end of the frame, (Figures 5 & 6). **WARNING!** Assistance is required to hold the bumper in place during hardware removal and to prevent the bumper from falling. Move the bumper to a clean stable work surface.
4. Determine if the bumper is equipped with sensors, (parking and tire pressure monitoring). NOTE: sensors must be installed in Bumper, (if equipped), before installing Bumper Assembly.

Models without bumper sensors:

- a. Select the included (4) Rubber Plugs.
- b. From behind bumper, push plugs into sensor mounts, (Figure 7). Screws have been provided to lock the plugs in the mount. Use is optional.

Models with bumper mounted sensors:

- a. Remove sensors from factory bumper, (Figure 8).
- b. Remove the outer plastic sleeve from the sensor, (Figure 9). Next, remove the silicone seal from the end of the sensor. Slide the larger Sensor Sealing Washer over the front of the sensor.
- c. Insert sensor with Seal into sensor mount, (Figure 10).
- d. Push Sensor Retaining Clip into sensor mount and lock into mounting holes, (Figure 10).
- e. Repeat previous Steps to install remaining sensors.

LD1 REAR BUMPER

09-18 RAM 1500, 19-20 1500 "CLASSIC," 10-20 25-3500

- f. Attach factory wiring harness to LD1 Bumper and plug into sensors. **NOTE:** Use the included (2) Wiring Harness Extensions as necessary to extend the reach of the harness to the sensors.

Models with TPMS (tire pressure monitoring system).

- a. Remove the sensor from the back of the bumper, **(Figure 11)**. **NOTE:** It may be necessary to partially disassemble the factory bumper to remove the sensor.
 - b. Attach the sensor to tabs on back of bumper with included (2) 4mm Button Head Screws, (4) 4mm Flat Washers, (2) 4mm Lock Washers and (2) 4mm Hex Nuts, **(Figure 12)**. Do Not Overtighten 4mm hardware or damage to sensor could result.
 - c. Once installed, plug wiring harness into TPMS sensor.
5. If installing lights, (lights not included), check for clearance around light. Remove back screens from light housings for additional clearance around lights as required, **(Figure 13)**. **IMPORTANT:** On models with Dual Exhaust, screens must be removed before installing the Bumper if lights are to be installed.
 6. Snap the trailer plug into the opening in the LD1 Bumper, **(Figure 14)**. If necessary, use a flat blade screwdriver to carefully pry the lock tab on the clip out to help lock plug in place.
 7. With assistance, position the LD1 Bumper up to the brackets on the ends of the frame. Temporarily support the weight of the Bumper Assembly. **WARNING:** To avoid possible injury or damage to the vehicle, do not proceed until the Bumper is fully and safely supported.
 8. Line up the (2) mounting holes in the back of the driver/left side of the bumper with the brackets on the end of the frame. Slide (1) 12mm Double Nut Plate behind the mounting plate on the Bumper, **(Figure 15)**. Attach the Bumper to the frame and Nut Plate with (2) 12mm Hex Bolts, (2) 12mm Lock Washers and (2) 12mm Flat Washers, **(Figures 15 & 16)**. Repeat this **Step** to attach the passenger/right side of the Bumper. Leave hardware loose at this time.
 9. Slowly open the tail gate and check for clearance. Level and adjust Bumper and tighten all hardware.
 10. Insert the included (2) push-in plugs to attach the license plate to the Bumper, **(Figure 17)**. Insert the included License Plate Light into the mounting hole in the bumper, **(Figure 17)**.
 11. Connect the license plate light harness to the License Plate Light. Reattach the wiring harness to the back of the trailer plug and back up sensors (if equipped). Use the included Wire Ties to secure the wiring harness to the bumper and frame. Seal off any open wire connections.
 12. Do periodic inspections to the installation to make sure that all hardware is secure and tight.

To protect your investment, Do not use any type of polish or wax that may contain abrasives that could damage the finish. Mild soap may be used to clean the LD1 Bumper assembly.

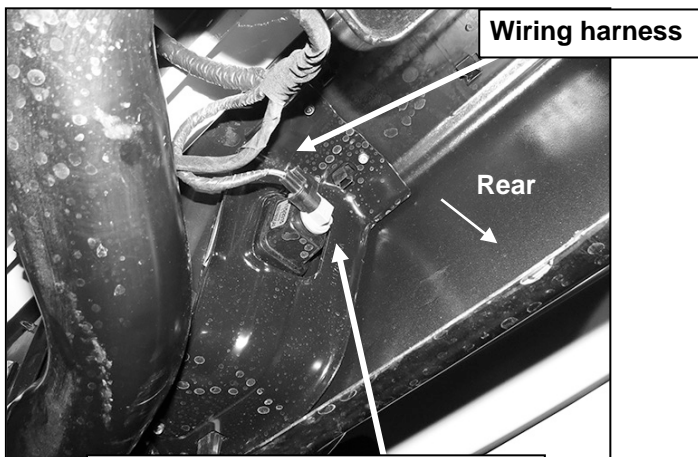

LD1 REAR BUMPER

09-18 RAM 1500, 19-20 1500 "CLASSIC," 10-20 25-3500

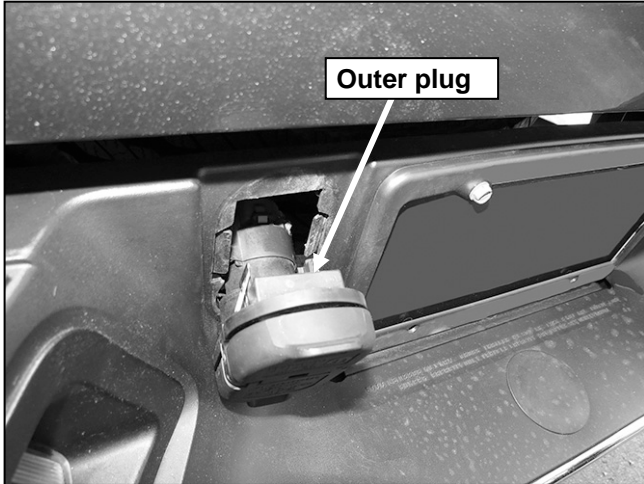

Outer plug

(Fig 3) Remove outer trailer plug from bumper

WARNING! Do not remove bumper bolts unless the bumper is properly supported on blocks or stands or the bumper may fall.

Models with dual exhaust, allow exhaust to completely cool before starting installation

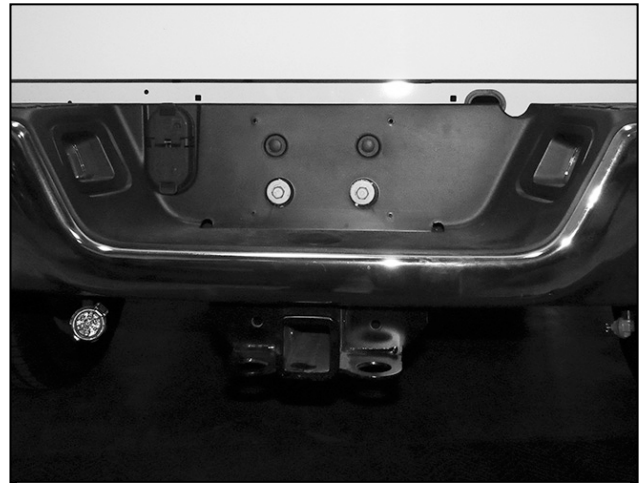

(Fig 4) Remove license plate and (2) hex bolts

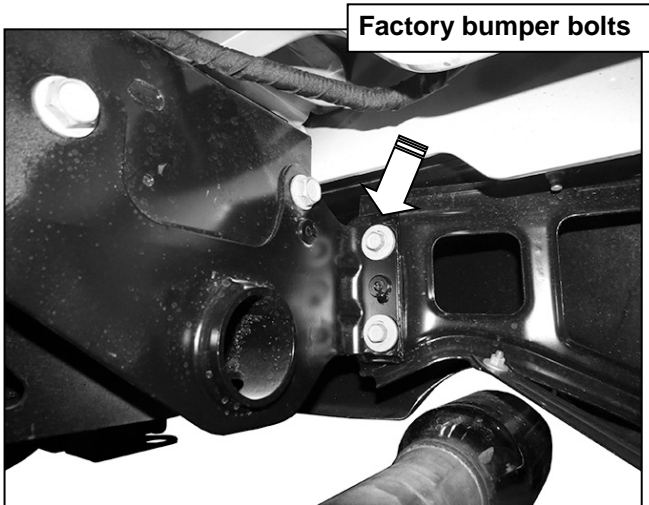

Factory bumper bolts

(Fig 5) Example of factory bumper bracket with (2) hex bolts pictured from behind bumper

Factory receiver hitch



Rear

(Fig 6) Bumper completely removed (1500 model pictured)

LD1 REAR BUMPER
09-18 RAM 1500, 19-20 1500 "CLASSIC," 10-20 25-3500

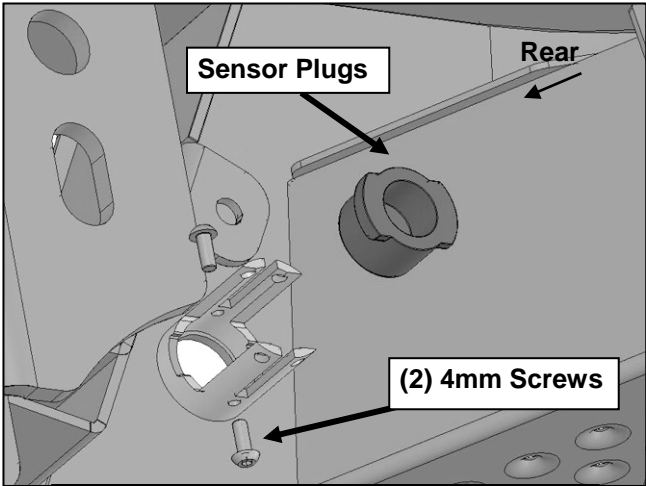

(Fig 7) Push sensor plug into mounting sleeve. Use of 4mm Screws is optional

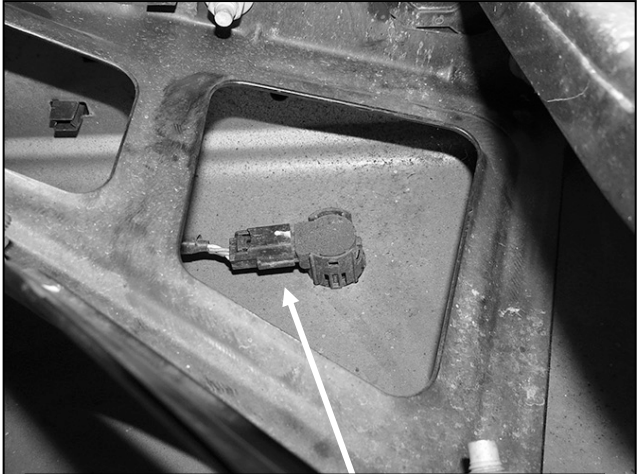

(Fig 8) Unplug the sensor first then remove the sensor from the mounting sleeve. Disassemble bumper to remove all sensors and harness as equipped



(Fig 9) Remove the sleeve (right) from each sensor

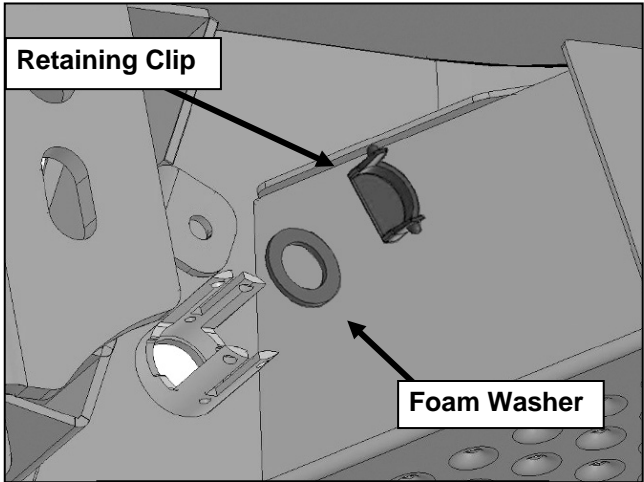

(Fig 10) Push sensor into sensor mount on the back of the Bumper

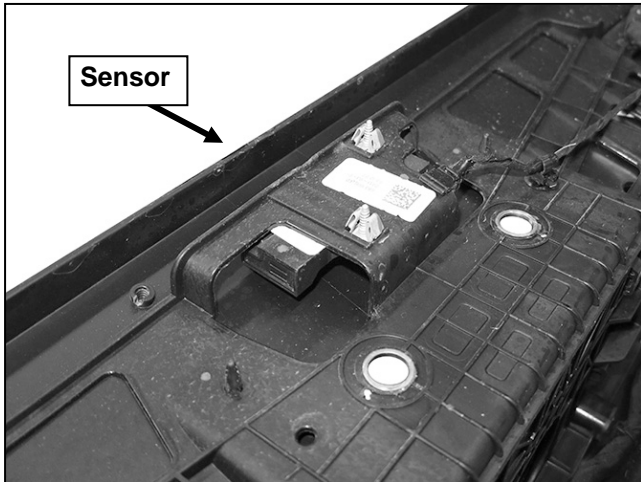

(Fig 11) Remove tire pressure monitoring sensor (TPMS) from back of bumper, if equipped

WARNING! Do not crawl under bumper unless the bumper is properly supported on blocks or stands or the bumper may fall.

- (2) 4mm Screws
- (4) 4mm Flat Washers
- (2) 4mm Lock Washers
- (2) 4mm Hex Nuts

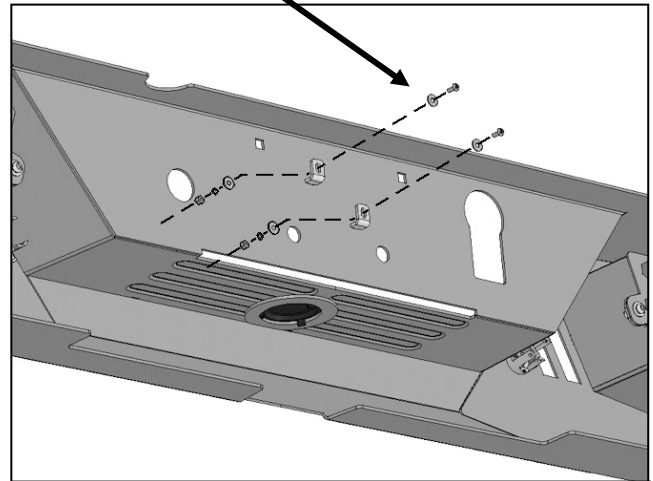

(Fig 12) Attach tire pressure monitoring sensor, if equipped, to tabs on back of bumper

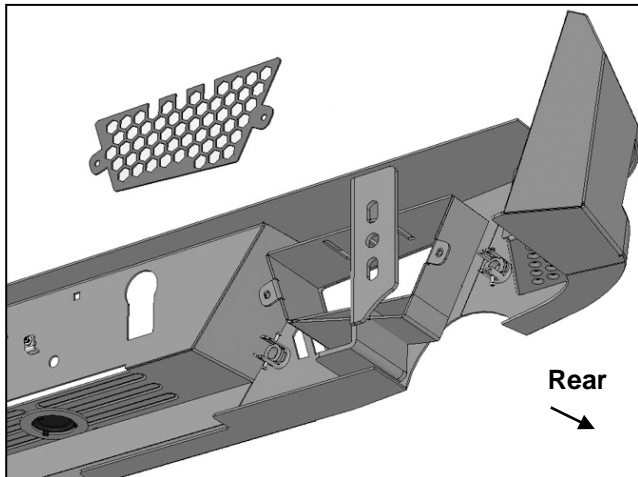

(Fig 13) Remove screens if necessary for additional clearance around or access to lights

IMPORTANT: On models with dual exhaust, if bumper installation will include accessory lights, check for clearance around lights before installing bumper. Screens cannot be removed once bumper is installed.

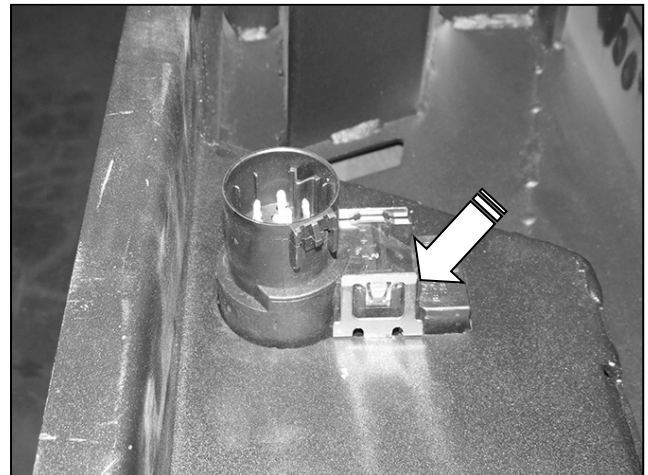

(Fig 14) Push plug into place. Carefully bend locking tab outward if necessary

LD1 REAR BUMPER
09-18 RAM 1500, 19-20 1500 "CLASSIC," 10-20 25-3500

- (2) 12mm Hex Bolts
- (2) 12mm Lock Washers
- (2) 12mm Flat Washers

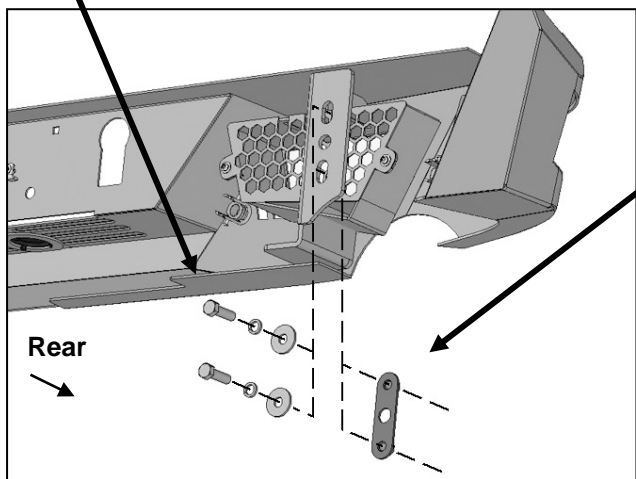

12mm Double Nut Plate

- (2) 12mm Hex Bolts
- (2) 12mm Lock Washers
- (2) 12mm Flat Washers



(Fig 16) Driver/left side pictured from behind bumper

- (2) Plastic plugs

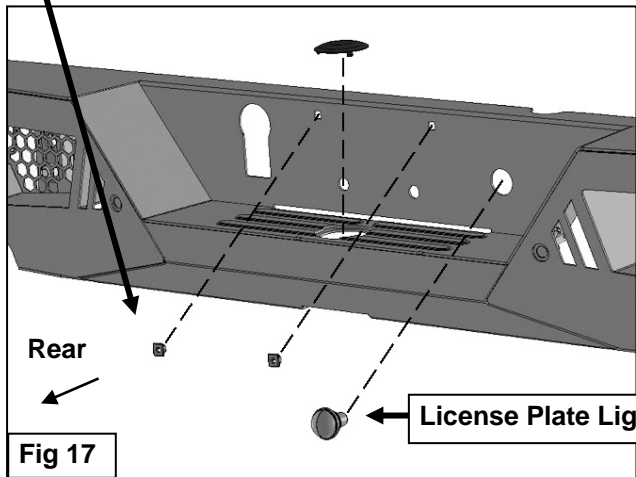

Fig 17

