



TEL: 1-866-XANATOS

INSTALLATION INSTRUCTIONS

BULL BAR 2011-2013 TOYOTA HIGHLANDER

PART # CBB-TYF5207SP/ CBS-TYF5207SP

PARTS LIST:

1	Bull Bar	1	12mm x 37mm OD x 3mm Flat Washer
1	Driver/Left Mounting Bracket	10	12mm x 32mm OD x 3mm Flat Washers
1	Passenger/Right Mounting Bracket	2	12mm Lock Washers
1	Driver/Left Support Bracket	4	12mm Nylon Lock Nuts
1	Passenger/Right Support Bracket	2	10-1.25mm x 35mm Hex Bolts
2	12-1.75mm x 90mm Bolt Plates	2	10mm x 27mm OD x 3mm Flat Washers
1	12-1.75mm x 90mm Hex Bolt	2	10mm Lock Washers
2	12-1.75mm x 35mm Hex Bolts	4	8mm x 24mm OD x 2mm Flat Washers
2	12-1.75mm x 30mm Hex Bolts		

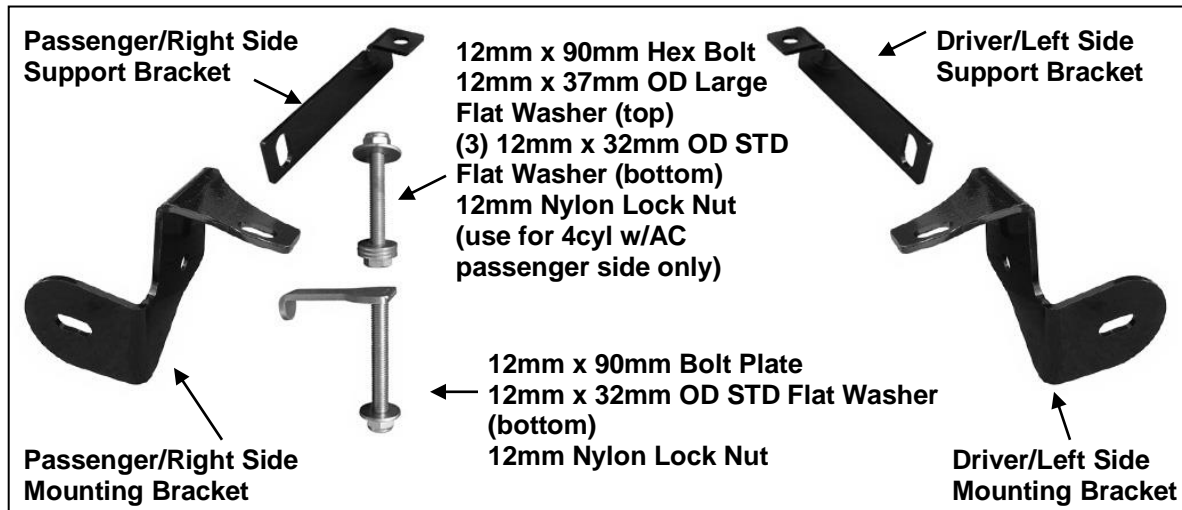

PROCEDURE:

1. REMOVE CONTENTS FROM BOX. VERIFY ALL PARTS ARE PRESENT. READ INSTRUCTIONS CAREFULLY BEFORE STARTING INSTALLATION. ASSISTANCE RECOMMENDED. CUTTING IS REQUIRED.
2. Remove the front plastic splash guard from under the front bumper and place it on a clean, stable work area.
3. Locate the factory vibration dampener on top of the cross member. The vibration dampener covers a mounting location for a Support Bracket. **NOTE:** The vibration dampener is typically located on the passenger side for hybrid models, (Figure 1), and on the driver side for gas models, (Figure 2). Temporarily remove the dampener from the top of crossmember. **IMPORTANT:** Pay close attention to how the dampener is mounted to the crossmember as it will be reinstalled.
4. Remove the plastic plugs covering the holes through the crossmember on the driver and passenger side, (Figure 3).

Gas Models (non Hybrid)

- a. **Driver Side Bolt Plate Installation:** Insert (1) 12mm x 90mm Bolt Plate down through the crossmember from the top, (Figures 4A & 4B). Re-install the suspension dampener over the Bolt Plate using the factory hardware. **NOTE:** Use the included 8mm Flat Washers on the factory hex bolts for spacers between the dampener and the crossmember as required for proper Bolt Plate clearance, (Figure 5). Rotate the lock tab on the Bolt Plate for proper fit between the crossmember and dampener.
- b. **Passenger Side Bolt Plate Installation-4cyl:** Due to the close proximity of the AC compressor, (if equipped), the 12mm x 90mm Bolt Plate cannot be used on the

passenger side bracket installation on 4cyl. vehicles. Skip to **Step 5** for the next step in the installation or see **Step 10b** for more information. On 4cyl. vehicles without air conditioning, insert a 12mm Bolt Plate as described below in **Step 4c, (Figure 6)**.

- c. **Passenger Side Bolt Plate Installation-V6:** Insert (1) 12mm x 90mm Bolt Plate down through the crossmember from the top, **(Figures 4B & 6)**. Rotate the lock tab on the Bolt Plate for proper fit on the crossmember.

Hybrid models

- a. **Driver Side Bolt Plate Installation:** Insert the Bolt Plate through the top of the cross member as described in **Step 4c, (Fig 4A)**. Rotate the lock tab on the Bolt Plate for proper fit on the crossmember.
 - b. **Passenger Side Bolt Plate Installation:** Insert (1) 12mm x 90mm Bolt Plate down through the crossmember from the top, **(Figure 6)**. Re-install the vibration dampener over the Bolt Plate using the factory hardware. **NOTE:** Use the included 8mm Flat Washers on the factory hex bolts for spacers between the dampener and the crossmember as required for proper Bolt Plate clearance, **(Figure 5 for example)**. Rotate the lock tab on the Bolt Plate for proper fit between the crossmember and the dampener.
5. Select the driver side Mounting Bracket. Locate the two factory bolts on the crossmember brace leading towards the bumper, **(Figure 7)**. Remove the factory hex bolt towards the outside of the vehicle, **(Figure 8)**. Position the driver side Mounting Bracket up to the bottom of the crossmember brace. Bolt the Mounting Bracket in place on the bottom of the brace using the included (1) 10-1.25mm x 35mm Hex Bolt, (1) 10mm Lock Washer and (1) 10mm Flat washer, **(Figure 9)**. Snug but do not tighten hardware at this time.
 6. Repeat **Step 5** for passenger side Mounting Bracket installation.
 7. Once you have attached the driver and passenger Mounting Brackets, hold the factory plastic splash guard up in its original mounting position and trace the location of the (2) Mounting Brackets and the (2) Bolt Plates onto the splash guard. Use a sharp knife to cut out the traced area for the Mounting Brackets, **(Figure 10)**. **IMPORTANT:** To maintain strength in the splash guard, only remove necessary material to clear the Mounting Brackets. Next, use a 1/2" drill bit or a sharp knife to open a hole for the threaded end of the (2) Bolt Plates to go through as described in **Step 4**.
 8. Temporarily re-install the splash guard onto the bottom of the vehicle but do not fasten-leave loose at this time.
 9. Select the driver side Support Bracket. Attach the end with the bent tab to the driver side Bolt Plate, (see **Step 4**), and over the splash guard with the included (1) 12mm x 32mm STD Flat Washer and (1) 12mm Nylon Lock Nut. Attach the flat end of the Support Bracket to the inside of the Mounting Bracket using the included (1) 12mm x 30mm Hex Bolt, (2) 12mm Flat Washers and (1) 12mm Nylon Lock Nut, **(Figures 6 & 13)**. Do not tighten hardware at this time. **NOTE:** The plastic cover under the engine/transmission will need to be trimmed slightly to clear the (2) Support Brackets, **(Figure 11)**.
 10. Select the correct vehicle model below for passenger side Support Bracket installation.
 - a. **V6 & Hybrid models:** Repeat **Step 9** for passenger side Support Bracket installation.
 - b. **4cyl. models:** Select the passenger side Support Bracket. Insert (1) 12mm x 90mm Hex Bolt with (1) 12mm x 32mm STD Flat Washer through the Support Bracket, splash guard and up through the holes in the crossmember, **(Figures 12A & 12B)**. Secure the Support Bracket and Hex Bolt with (1) 12mm x 37mm Large Flat Washer and (1) 12mm Nylon Lock Nut on top of the crossmember below the AC Compressor. **IMPORTANT:** There must be a minimum 15mm gap between the 12mm x 90mm Hex Bolt and the AC compressor. (2) additional 12mm Flat Washers have been provided for use as a spacer.

Use a maximum of (3) Flat Washers under the head of the 12mm x 90mm Hex Bolt as necessary, **(Figures 12A & 12B)**. Snug but do not tighten hardware.

11. With assistance, position the Bull Bar up to the Mounting Brackets. Attach the Bull Bar to the Mounting Brackets using the included (2) 12mm x 35mm Hex Bolts, (2) 12mm Lock Washers and (2) 12mm Flat Washers, **(Figure 13)**.

12. Level and adjust the Bull Bar properly and tighten all hardware at this time.

13. Completely secure the splash guard to the vehicle with the factory hardware.

14. Do periodic inspections to the installation to make sure that all hardware is secure and tight.

To protect your investment, wax this product after installing. Regular waxing is recommended to add a protective layer over the finish. Do not use any type of polish or wax that may contain abrasives that could damage the finish.

For stainless steel: Aluminum polish may be used to polish small scratches and scuffs on the finish. Mild soap may be used also to clean the Bull Bar.

For gloss black finishes: Mild soap may be used to clean the Bull Bar.

Hybrid Models: The vibration dampener is located on the passenger side of the front cross member

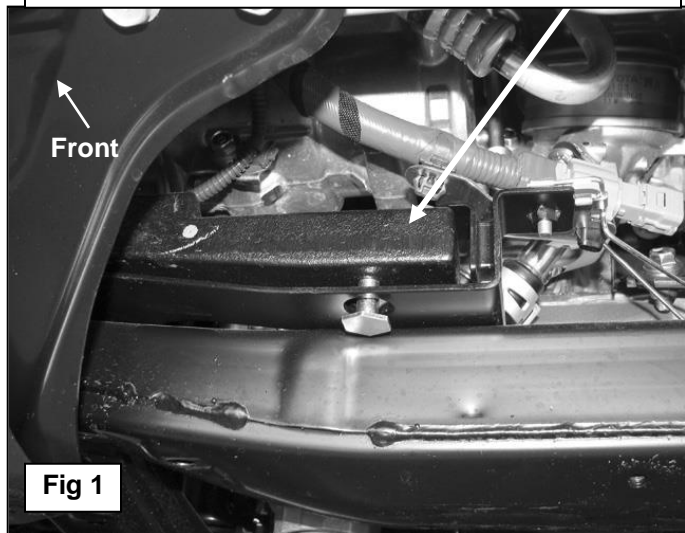

Gas Models: The vibration dampener is located on the driver side of the front cross member

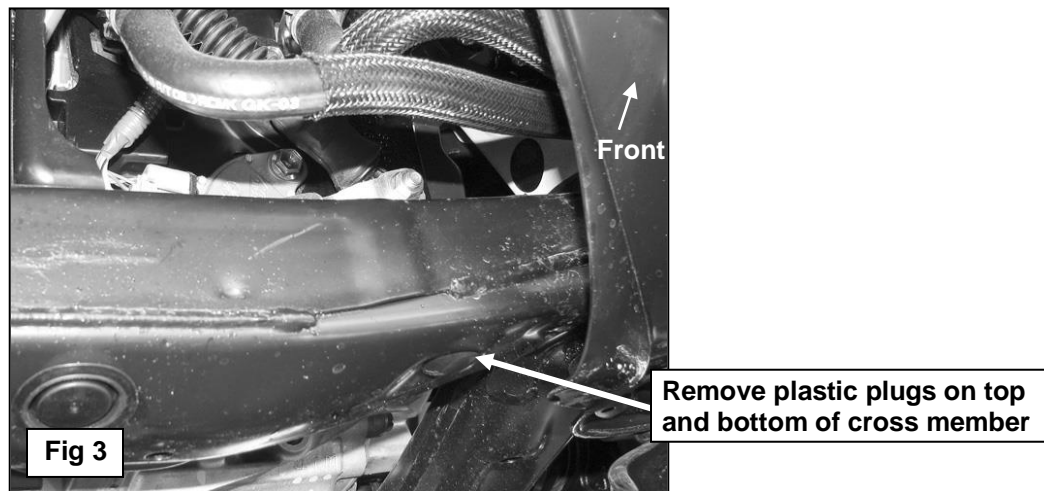
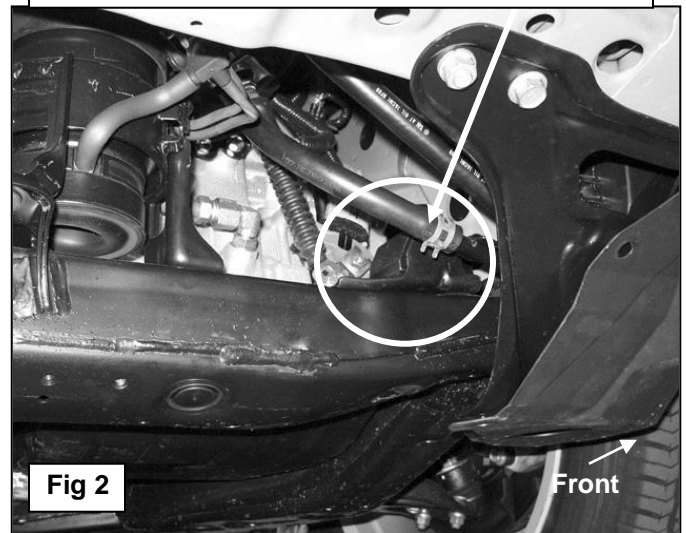

12mm x 90mm Bolt Plate

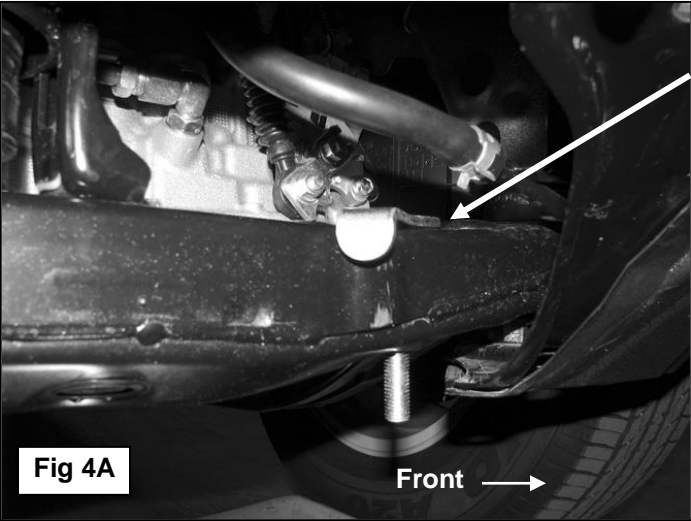

Insert (2) 8mm Flat Washers between the vibration dampener and the cross member (driver side pictured)

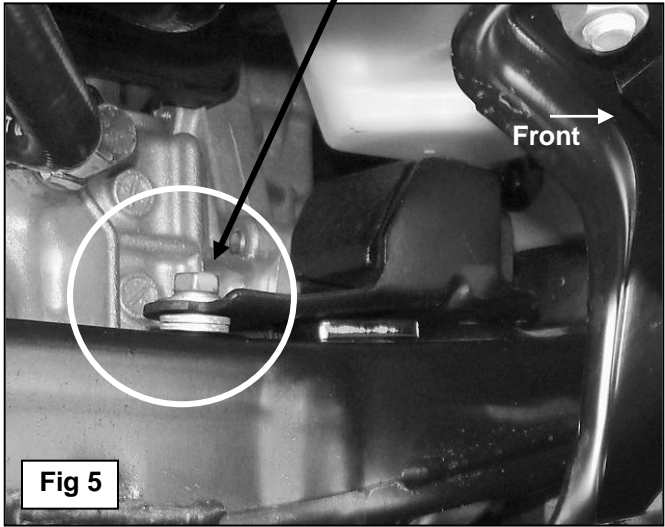
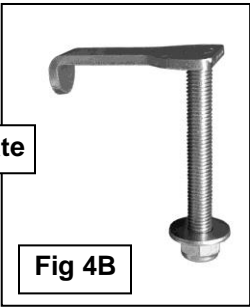

Fig 4A

Front →

Front →

Fig 5



12mm x 90mm Bolt Plate

Fig 4B

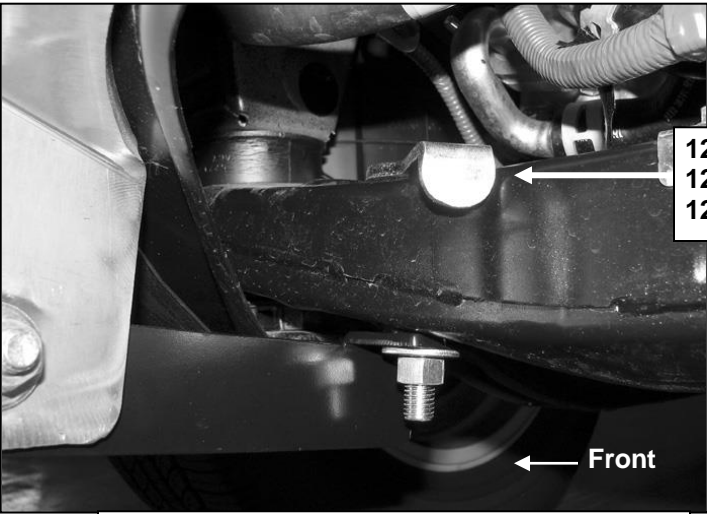

12mm x 90mm Bolt Plate
12mm Flat Washer
12mm Nylon Lock Nut

(Fig 6) Passenger side pictured with Support Bracket in place for reference only

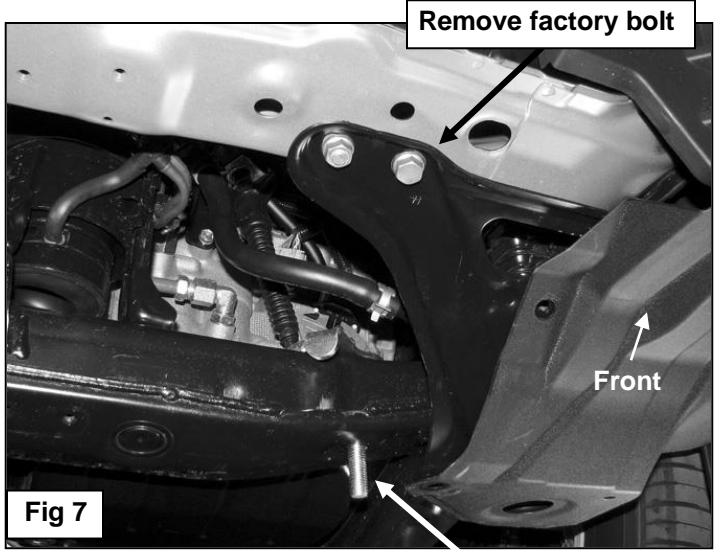

Remove factory bolt

Front →

Fig 7

12mm x 90mm Bolt Plate

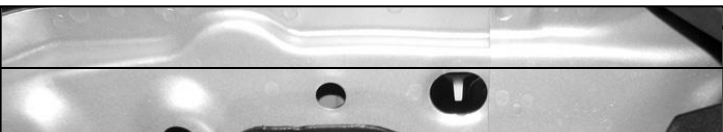

Replace factory bolt with
10-1.25 x 35mm Hex Bolt
10mm Lock Washer
10mm Flat Washer

Replace factory bolt with
10-1.25 x 35mm Hex Bolt
10mm Lock Washer
10mm Flat Washer

Fig 8

12mm x 90mm Bolt Plate
12mm Flat Washer
12mm Nylon Lock Nut
(Support Bracket pictured
in place for reference only)

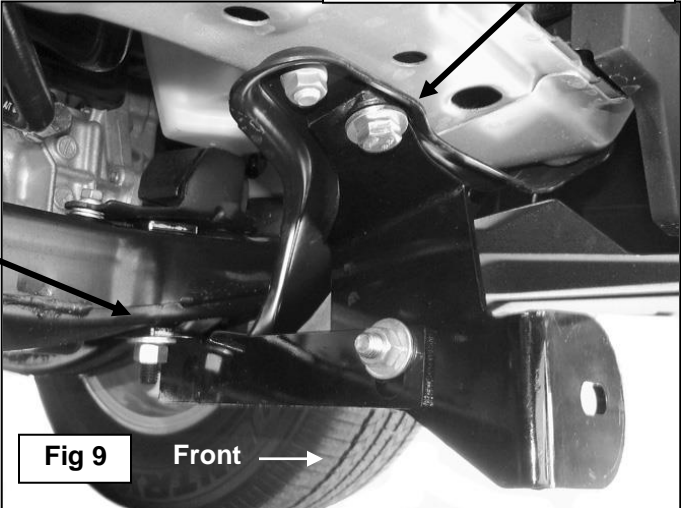

Cut (2) openings through splash guard
for Mounting Brackets (illustrated for
example only. Actual cut out area may
differ according to installation)

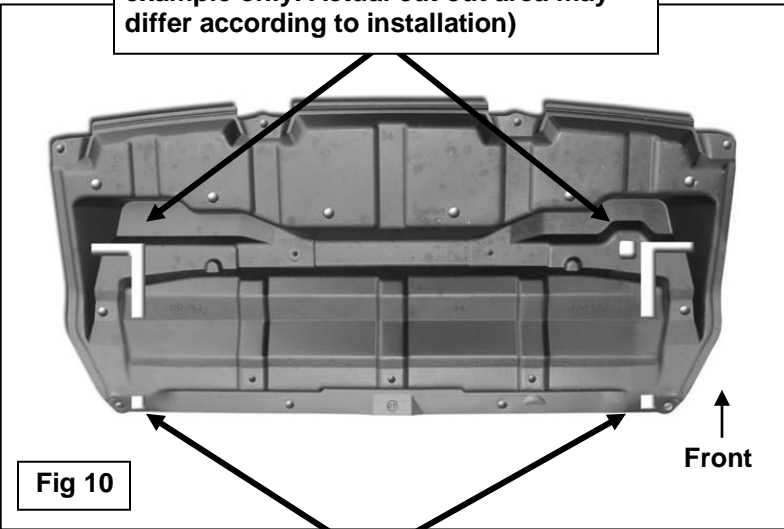

Cut (2) openings through splash
guard for Bolt Plates, (illustrated for
example only. Actual cut out area
may differ according to installation)

Cut (2) openings through front of plastic engine
cover to clear Support Brackets and Bolt Plates,
(illustrated for example only. Actual cut out area
may differ according to installation)

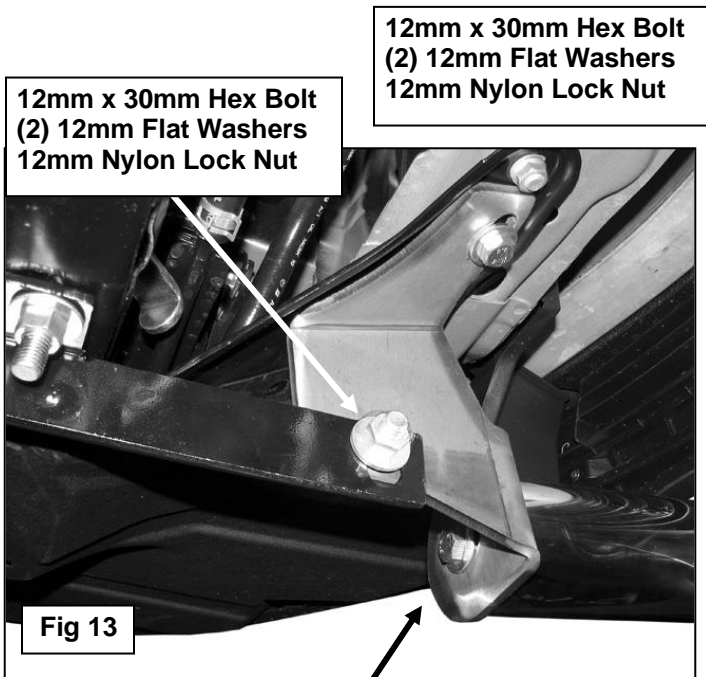
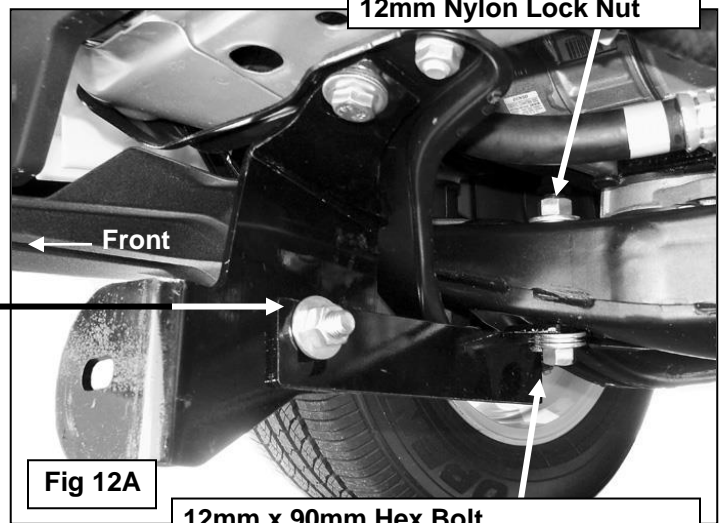
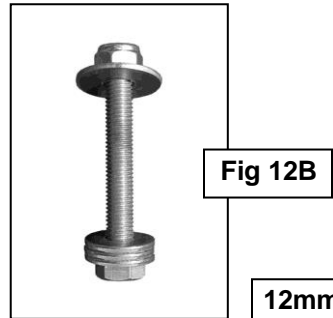
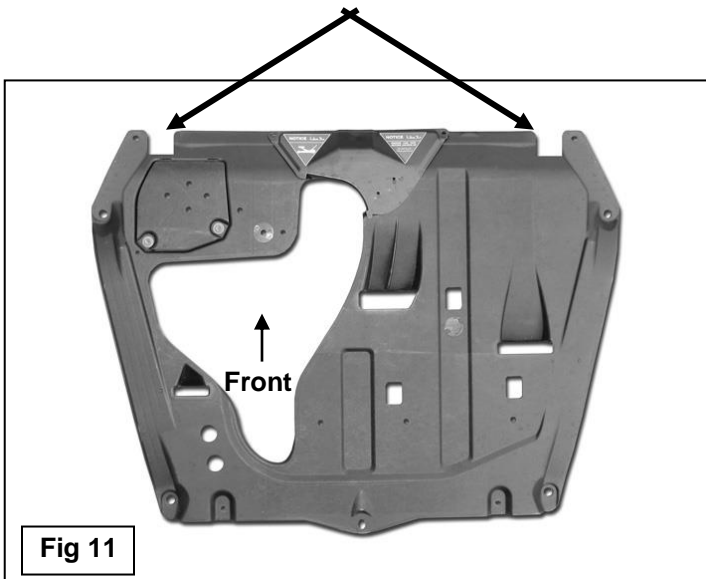

12mm x 30mm Hex Bolt
(2) 12mm Flat Washers
12mm Nylon Lock Nut

12mm x 90mm Hex Bolt
(3) 12mm STD Flat Washers
(4cyl vehicle pictured without splash guard in place for photo purposes only)

Bolt Bull Bar to Brackets with:
(2) 12mm x 35mm Hex Bolts
(2) 12mm Flat Washers
(2) 12mm Lock Washers
(Pictured without splash guard in place for photo purposes only)

