

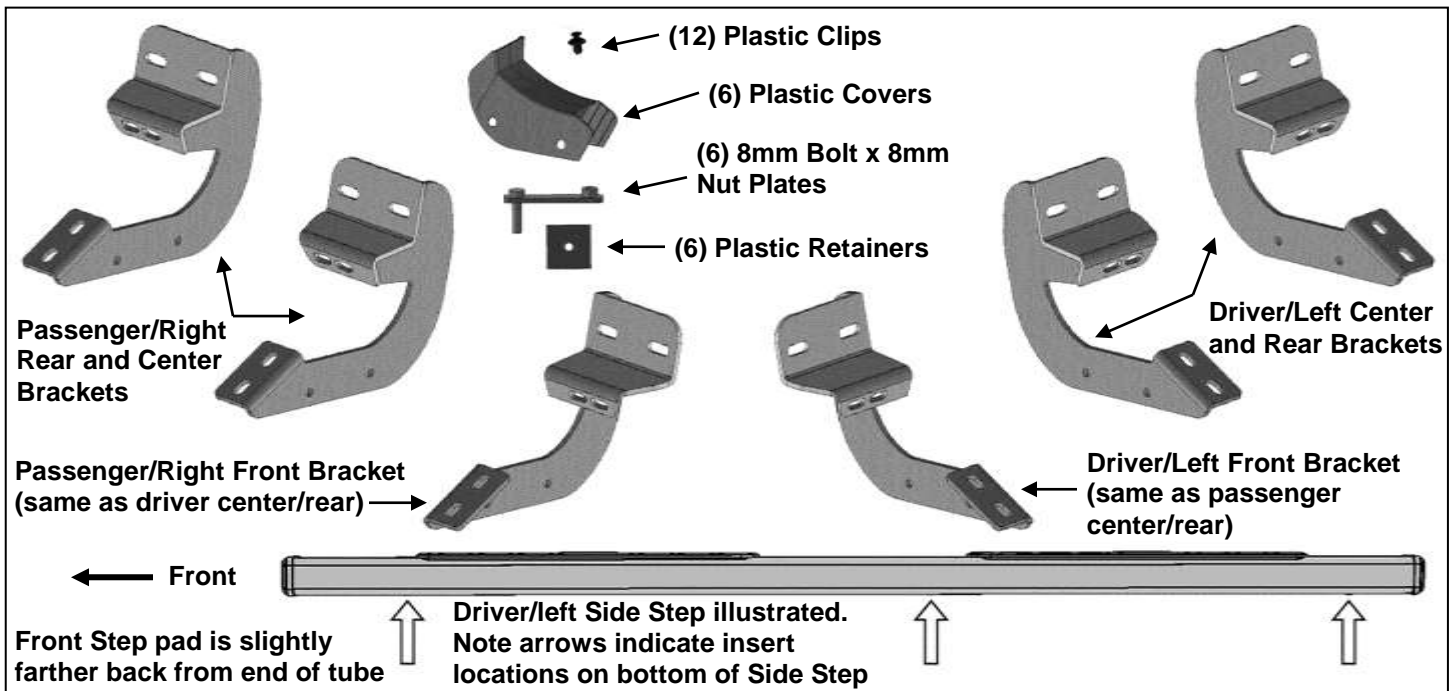

**INSTALLATION INSTRUCTIONS**  
Summit Running Boards for DODGE RAM 1500 QUAD CAB 09-17  
PART # SU-DO0276BK/SU-DO0276SS

**PARTS LIST:**

1	Driver/Left Side Step	12	8-1.25mm x 30 Hex Bolts
1	Passenger/Right Side Step	12	8mm x 24mm x 2mm Flat Washers
3	Driver/left Front Bracket (also fits passenger/right center and rear locations)	12	8mm Lock Washers
3	Passenger/right Front Bracket (also fits driver/left center and rear locations)	6	8mm Hex Nuts
6	Plastic Bracket Covers	12	8-1.25mm x 25mm Combo Hex Bolts
12	Plastic Clips for Covers	12	6-1.0mm x 25mm Socket Head Bolt
6	8mm Nut/Bolt Plates	24	6mm x18mm x 1.6mm Flat Washers
6	8mm Plastic Retainers	12	6mm Flange Nuts
		1	Allen Key



**PROCEDURE:**

- REMOVE CONTENTS FROM BOX. VERIFY ALL PARTS ARE PRESENT. READ INSTRUCTIONS CAREFULLY BEFORE STARTING INSTALLATION. DRILLING MAY BE REQUIRED.**
- Starting at the driver side-front of the vehicle, remove the sealing tape covering the factory holes in the side of the inner panel, **(Figure 1)**.
- Determine the correct procedure to attach the driver side front Bracket for your model/year:
 

**Models without factory threaded inserts in body panel:**

  - Select (1) 8mm Bolt/nut Plate, **(Figure 2)**. Partially thread an 8mm Hex Bolt onto the threaded end of the Nut Plate, **(Figure 3)**. Thread the Hex Bolt in until it is flush with the welded nut. Use the Hex Bolt as a handle and insert the Bolt and Nut Plate into the oval hole, **(Figure 4)**. Feed the threaded bolt on the Bolt Plate through one of the hex shaped factory holes.
  - Thread (1) 8mm Plastic Retainer onto the threaded end and down tight against the body panel, **(Figure 5)**. **NOTE:** The Plastic Retainer is designed to keep the Bolt/Nut Plate from falling into the body panel and to aid in Bracket installation.
  - Select the driver side front Mounting Bracket, **(Figure 6)**. Attach the Bracket to the threaded end of the Bolt Plate with (1) 8mm Flat Washer, (1) 8mm Lock washer and (1) 8mm Hex Nut, **(Figure 7)**. **IMPORTANT:** Driver/left front Bracket is the same as the passenger/right center and rear Brackets. Do not tighten hardware at this time.
  - Remove the 8mm Hex Bolt from the nut on the Bolt Plate from **Step 3a**. Rotate the Bolt on the Bolt Plate until the threaded nut lines up with the remaining hole in the Mounting Bracket and

body panel, **(Figure 7)**. Attach the Bracket to the threaded Nut Plate with (1) 8mm x 30mm Hex Bolt, (1) 8mm Lock Washer and (1) 8mm Flat Washer, **(Figure 7)**. Do not tighten hardware.

**Models with factory threaded inserts:**

- a. Attach the driver side Front Bracket to the threaded inserts with (2) 8mm x 30mm Hex Bolts, (2) 8mm Lock Washers and (2) 8mm Flat Washer, **(Figures 8 & 9)**. Leave hardware loose.
4. Next, attach the Bracket to the back of the pinch weld with (2) 6mm x 25mm Socket Head Screws, (4) 6mm Flat Washers and (2) 6mm Flange Nuts, **(Figures 10 & 11)**. Do not fully tighten hardware at this time. **IMPORTANT:** 2009-10 models are not equipped with factory holes and will require drilling through the pinch weld to attach the Support Bracket. Do not drill through pinch weld at this time, **(see Step 8)**.
5. Select (1) Plastic Bracket Cover and (2) Retaining Clips. Slide the Cover over the driver side front Bracket. Line up the (2) mounting holes in the Cover with the holes in the Bracket. Insert the Clip into the holes and push center pin to expand Clip, **(Figure 12)**. Repeat this Step for all Cover installation.
6. Move along the side of the body panel to the center mounting location, **(Figure 13)**. Repeat the appropriate **Steps 2—5** to install the driver side center Bracket, **(Figure 14)**. **IMPORTANT:** The front bracket is different from the center and rear Mounting Brackets, (see illustration above-note direction of mounting plate).
7. Move to the rear location, **(Figure 15)**. Repeat **Step 6** to install the rear Mounting Bracket, **(Figure 16)**.
8. Select the driver/left Sidebar. Carefully position the Driver Sidebar onto the (3) Mounting Brackets. **IMPORTANT:** Do not slide, (front to back or rotate), the Sidebar on the Brackets or damage to the finish on the Sidebar may result. Attach the Side Step to the (3) Brackets with (6) 8mm Combination Hex Bolts, **(Figures 17—19)**. Do not fully tighten at this time.
9. Properly level and adjust the Sidebar and fully tighten all hardware.  
**2009-10 models requiring drilling for driver side Support Brackets:**
  - a. Level the Side Step to the vehicle. Make sure all (3) Brackets are tight against the bottom of the body panel and tighten all mounting hardware.
  - b. Mark the location of the slots onto the pinch weld.
  - c. Drill (2) 1/4" holes through the pinch weld for each Support Bracket. **IMPORTANT:** Do not drill too close to the bottom edge of the pinch weld. Drill the holes in the center of the marked slots.
  - d. Repeat **Step 4** to attach the Brackets to the drilled holes in the pinch weld. Check for level then fully tighten all hardware.
10. Move to the passenger side of the vehicle. Remove tape covering front, center and rear locations. Repeat **Steps 2—9** for passenger side Mounting Bracket installation. **NOTE:** Refer to the illustration on **Page 1** to identify the correct Mounting Bracket for each of the remaining locations.
11. Do periodic inspections to the installation to make sure that all hardware is secure and tight.

**To protect your investment**, wax this product after installing. Regular waxing is recommended to add a protective layer over the finish. Do not use any type of polish or wax that may contain abrasives that could damage the finish.

**For stainless steel:** Aluminum polish may be used to polish small scratches and scuffs on the finish. Mild soap may be used also to clean the Side Steps.

**For gloss black finishes:** Mild soap may be used to clean the Side Steps.

### Driver Side Installation Pictured

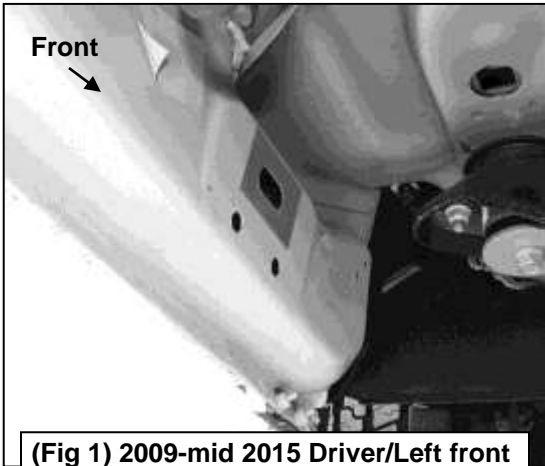

(Fig 1) 2009-mid 2015 Driver/Left front mounting location (No factory holes in pinch weld 2009-2011 models)



(Fig 2) 8mm Bolt-8mm Nut Plate, NOTE: 8mm Bolt-Nut Plate is not required on models with threaded inserts

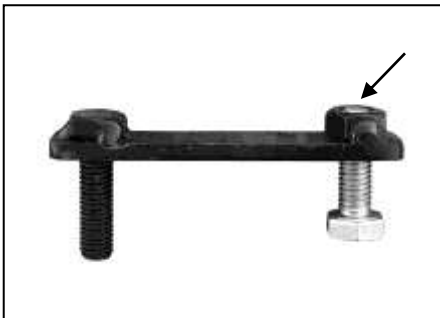

(Fig 3) Thread (1) 8mm Hex Bolt into the nut on the plate. Stop when bolt reaches end of nut as pictured

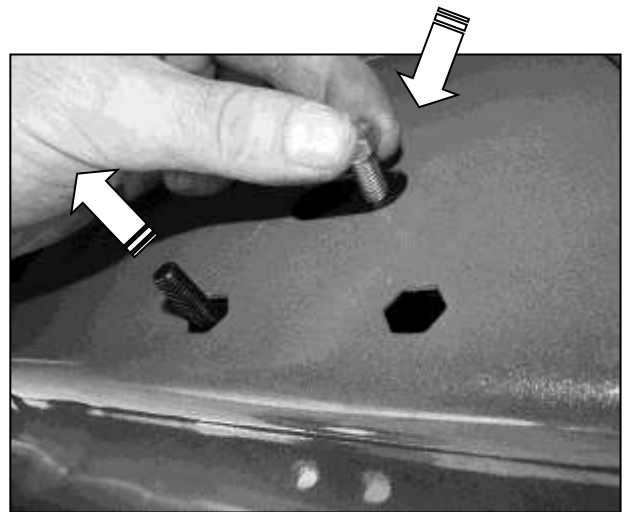

(Fig 4) Use the loose Hex Bolt as a handle. Insert the Bolt Plate into the oval hole and feed the threaded end out either factory hex shaped hole. IMPORTANT: Do not let go of the hex bolt until after Plastic Retainer has been threaded onto bolt (Fig 5)

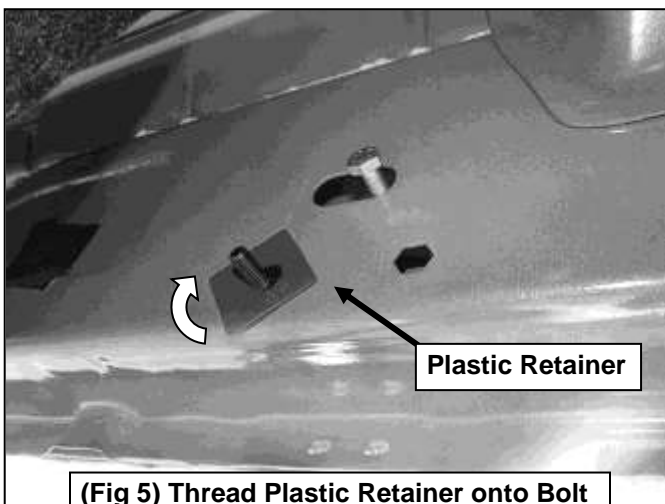

(Fig 5) Thread Plastic Retainer onto Bolt Plate to hold Bolt Plate in position.

### Driver Side Installation Pictured

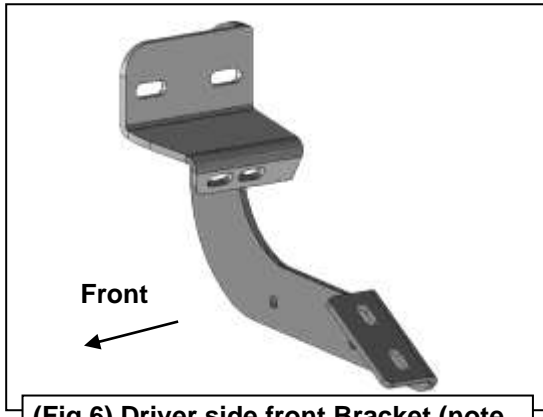

(Fig 6) Driver side front Bracket (note same Bracket is used on passenger side center and rear locations)

8mm Flat Washer  
8mm Lock Washer  
8mm Hex Nut

8mm Hex Bolt  
8mm Lock Washer  
8mm Flat Washer

Plastic Retainer

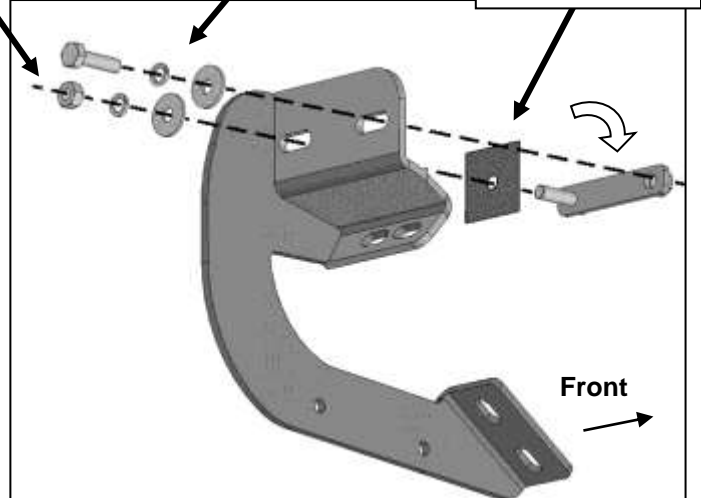

(Fig 7) Attach Bracket to threaded end of Bolt Plate first. Remove 8mm Hex Bolt (see Fig 3). Rotate Bolt Plate to line up with remaining factory hex shaped hole.

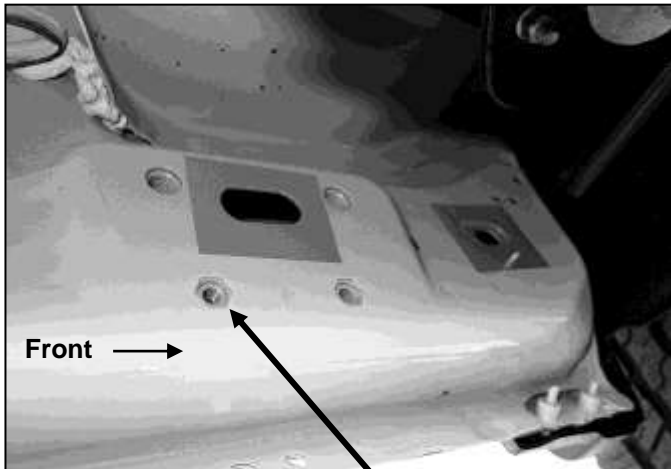

(Fig 8) Driver side front mid 2015-on, an example of models with factory installed threaded inserts

(2) 8mm Hex Bolts  
(2) 8mm Lock Washers  
(2) 8mm Flat Washers

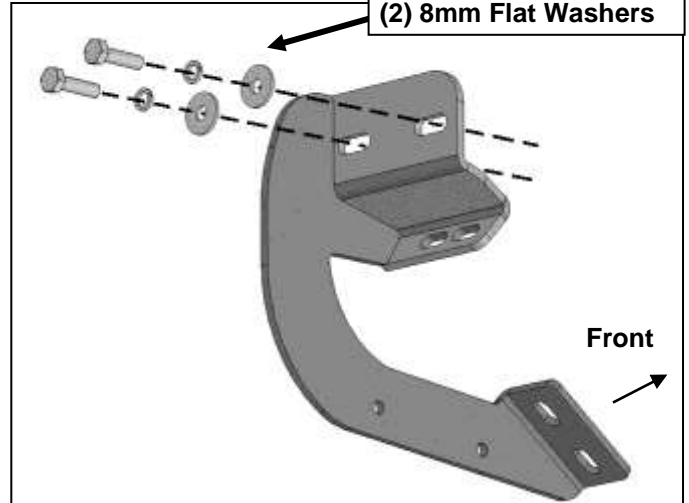

(Fig 9) Driver side front models with factory installed threaded inserts. Bolt Plate not required

(2) 6mm Screws  
(4) 6mm Flat Washers  
(2) 6mm Flange Nuts

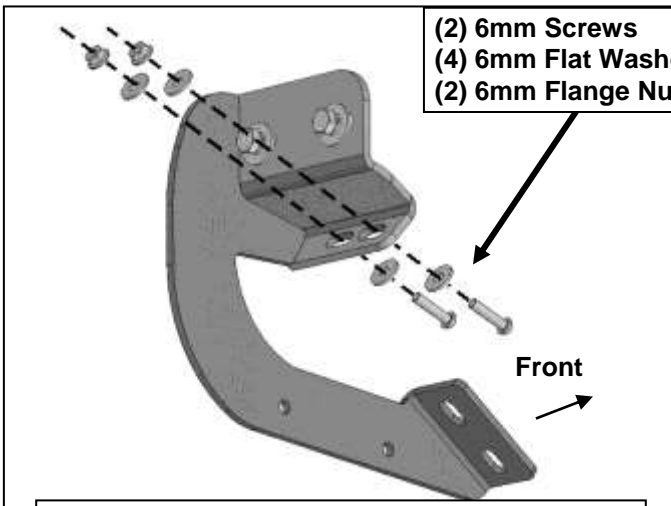

(Fig 10) Attach Bracket to back of pinch weld (models with factory holes in pinch weld only)

### Driver Side Installation Pictured

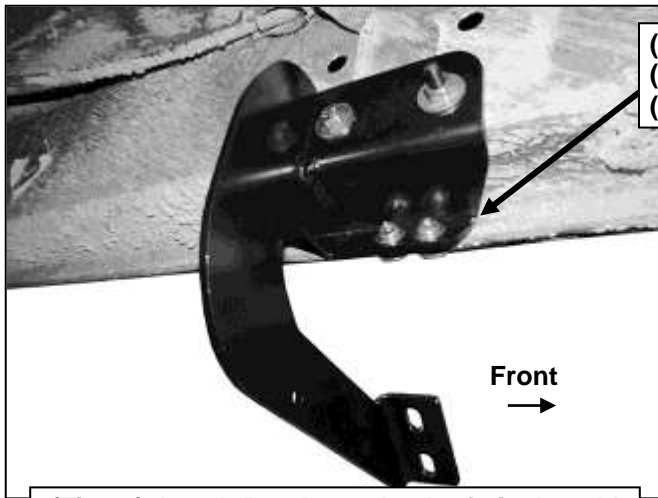

- (2) 6mm Screws
- (4) 6mm Flat Washers
- (2) 6mm Flange Nuts

(Fig 11) Attach Bracket to back of pinch weld (models with factory holes in pinch weld only)

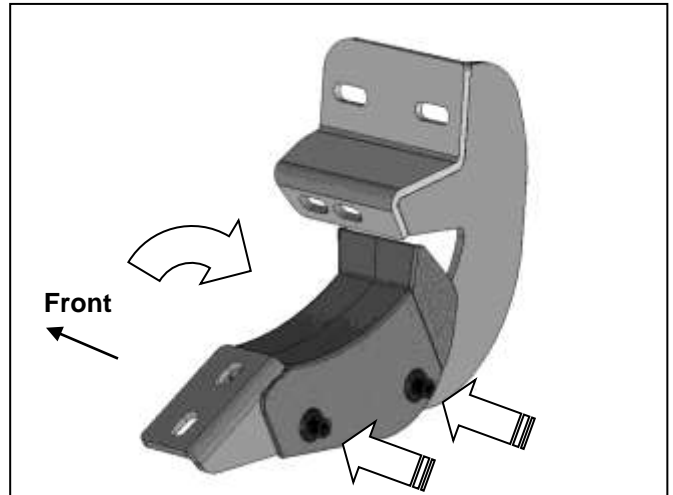

(Fig 12) Slide Cover over top of Bracket. Attach Cover to Bracket with (2) Retaining Clips

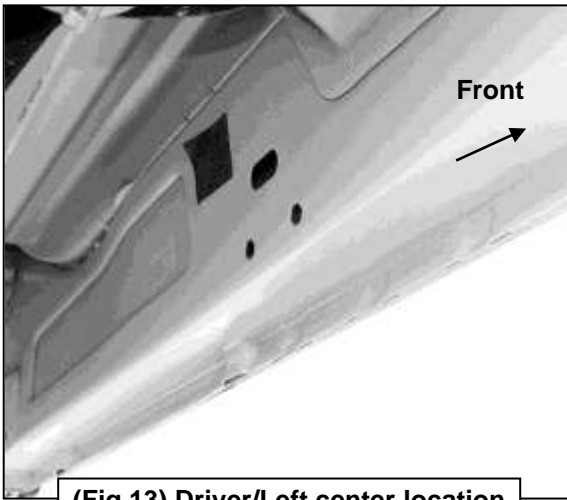

(Fig 13) Driver/Left center location

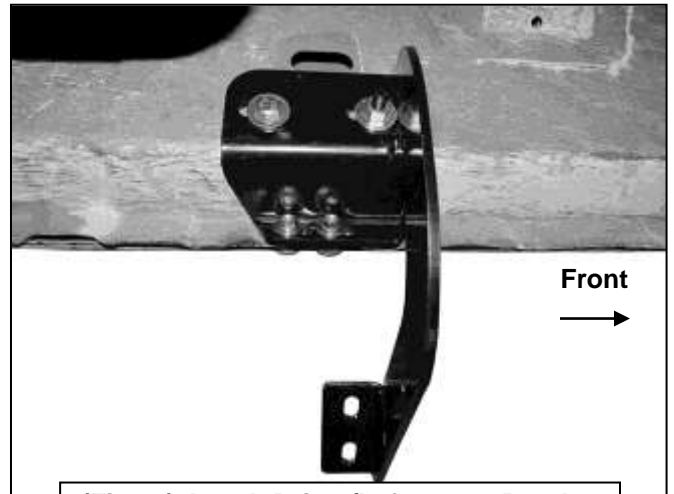

(Fig 14) Attach Driver/Left center Bracket

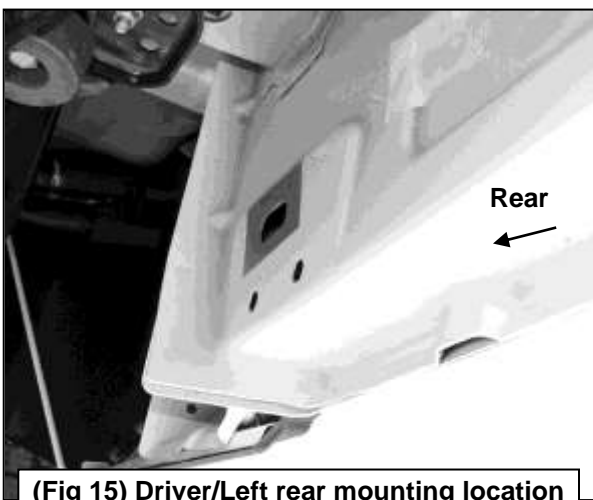

(Fig 15) Driver/Left rear mounting location

**IMPORTANT:** 2009-2010 models without holes in pinch weld will require drilling 1/4" holes through pinch weld to attach driver side front support bracket. Do complete installation of sidebars first, level sidebar before drilling holes for support bracket.

### Driver Side Installation Pictured

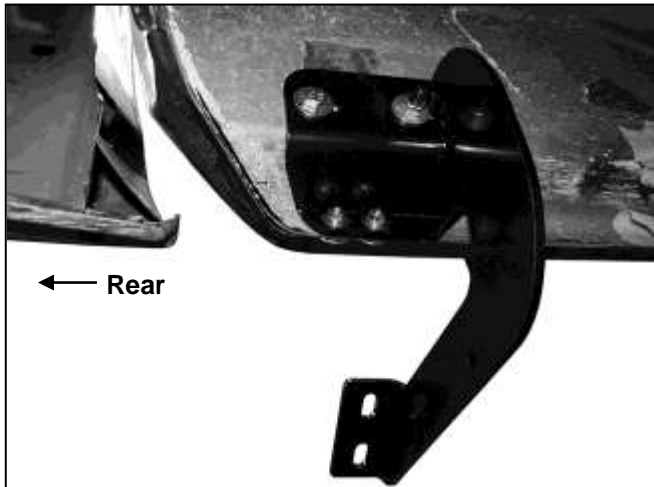

(Fig 16) Driver/Left rear Mounting Bracket assembly

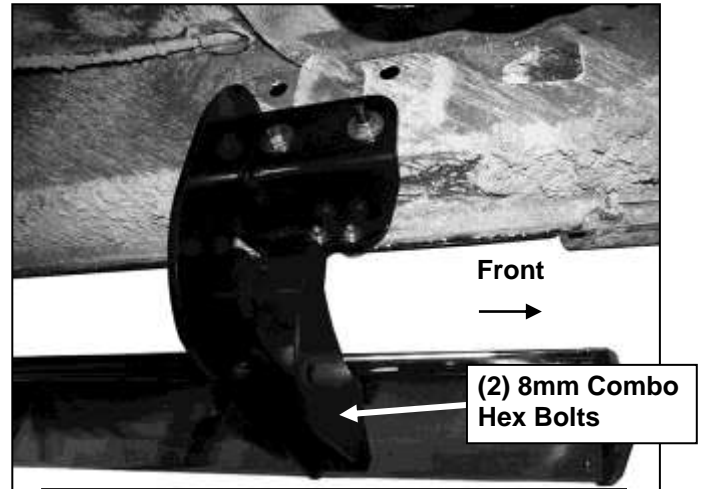

(Fig 17) Driver/Left front Mounting Brackets

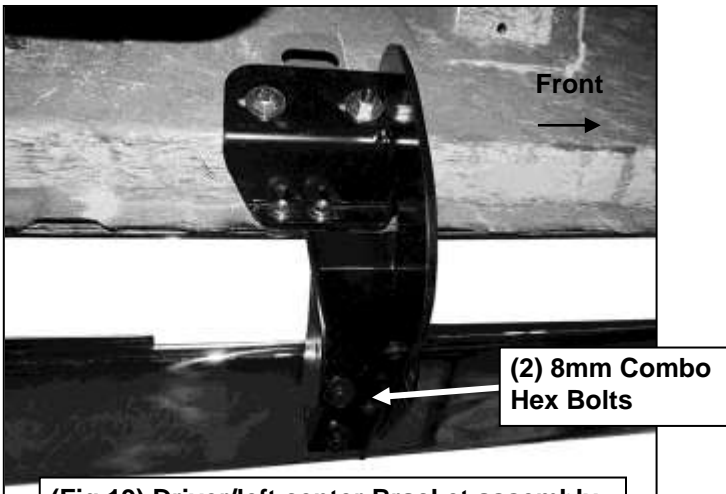

(Fig 19) Driver/left center Bracket assembly

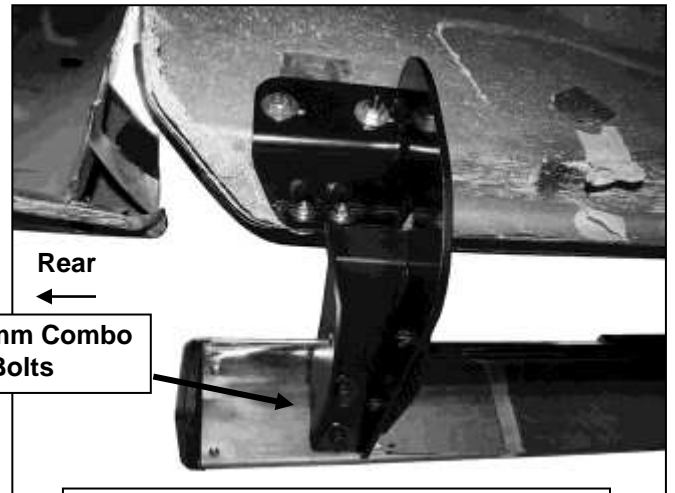

(Fig 19) Driver/left rear Bracket assembly

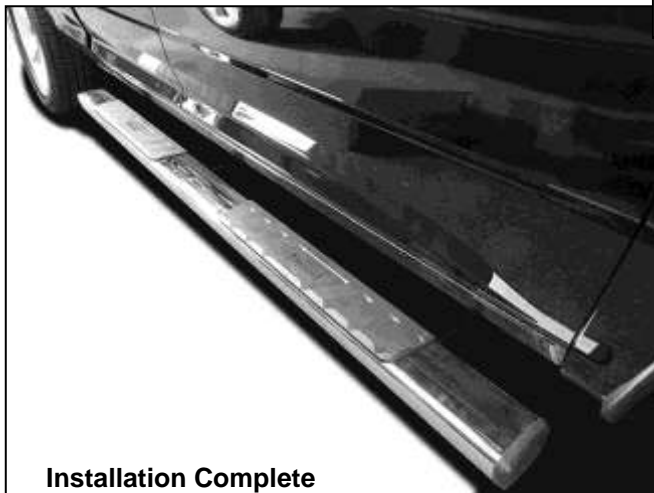

**IMPORTANT:** 2009-2010 models without holes in pinch weld will require drilling 1/4" holes through pinch weld to attach driver side front support bracket. Do complete installation of sidebars first, level sidebar before drilling holes for support bracket.