

Installation for Jeep Wrangler PN 140479



These instructions have been written to help you with the installation of your Borla Performance Exhaust System. Please read this document completely before beginning the installation of your system.

Please compare the parts in the box with the bill of materials provided to assure that you have all the parts necessary for this installation.

Thank you for purchasing a Borla Performance Cat-Back™ [Exhaust System](#).

Borla Performance Cat-Back™ Exhaust System (Part number 140479) is designed for the Jeep Wrangler 4 door , equipped with a 3.6L V6 engine, four-wheel drive and automatic and manual transmissions.

Borla Performance Industries recommends that an exhaust shop or professional after market parts installer perform the installation of this system. However, if you decide to perform the installation on your own it is recommended that two people are used. This installation should not be performed by one person due to the risk of injury. Ensure the installers use all under car safety precautions including eye protection.

Please take time to read and understand the following...

By installing your Borla Performance Exhaust System, you indicate that you have read this document and you agree with the terms stated below.

It is the responsibility of the purchaser to follow all installation instruction guidelines and safety procedures supplied with your Borla Performance Exhaust System

Borla Performance Industries assumes no responsibility for damages occurring from misuse, abuse, improper installation, improper operation, lack of responsible care, or all previously stated reasons resulting from incompatibility with other manufacturer's products and/or systems.

Minimum Required Tool List:

TOOLS:

1. 3/8" Drive Ratchet
2. 3/8" Drive Extension 3"
3. 14mm, 15mm Deep Well Socket
4. Pry Bar

SHOP SUPPLIES:

- 1 Spray Lubricant

Borla Performance - Bill of Materials

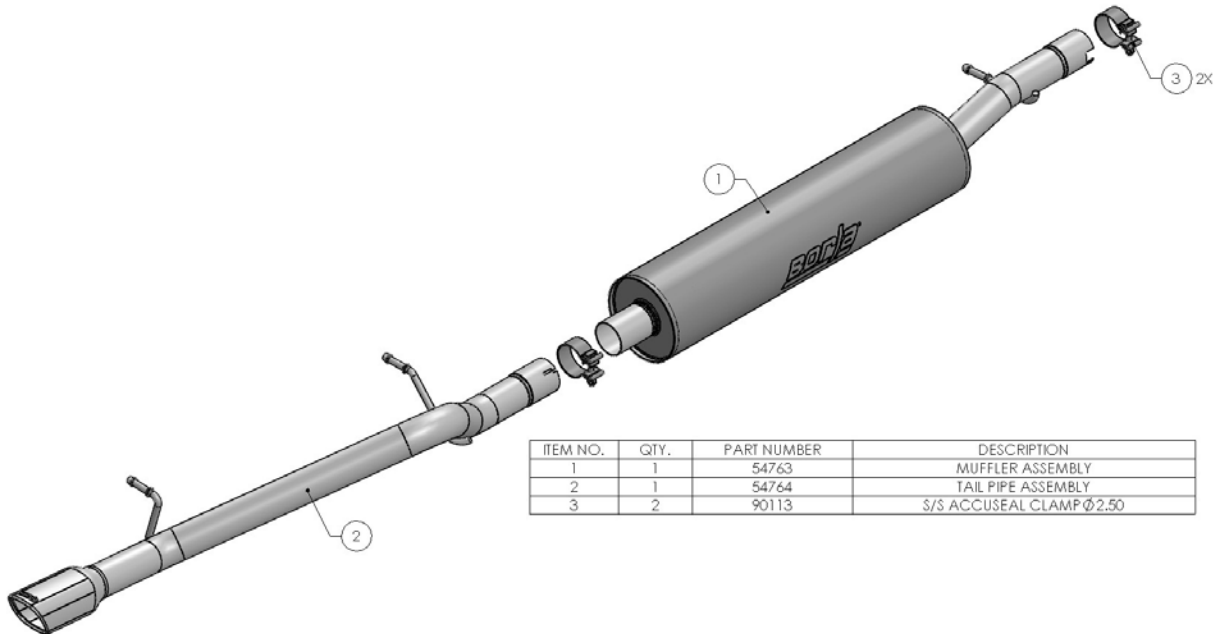

ITEM NO.	QTY.	PART NUMBER	DESCRIPTION
1	1	54763	MUFFLER ASSEMBLY
2	1	54764	TAIL PIPE ASSEMBLY
3	2	90113	S/S ACCUSEAL CLAMP Ø2.50

Caution!!! Never work on a hot exhaust system. Serious injury in the form of burns can result If the vehicle has been in use and the exhaust system is hot, allow vehicle to cool for at least 1 hour. Always wear eye protection when working under any vehicle.

Note: It is our recommendation that you use a hoist or hydraulic lift to facilitate the installation of your new Borla Performance Rear Section Exhaust System.

Taking all under car safety precautions, lift the vehicle using a hoist or hydraulic lift. Once this has been done, you may begin the removal of your old exhaust system from your vehicle.

Note: Before removing the original exhaust system from your vehicle, please compare the parts you have received with the bill of materials provided on the previous page to assure that you have all the parts necessary for the installation of your new Borla Performance Rear Section Exhaust System.

Original Exhaust System Removal

Note: With a used vehicle, we suggest a penetrating spray lubricant to be applied liberally to all exhaust fasteners and allowing a significant period of time for the chemical to lubricate the threads before attempting to disassemble.

1. Lubricate all hangers and rubber brackets.
2. Loosen clamp on rear muffler assembly. Remove the two hangers located on the rubber brackets and remove this assembly from vehicle. (See Fig. 1)
3. Loosen clamp on front muffler assembly. Remove the two hangers located on the front muffler assembly from the rubber brackets and remove this assembly from vehicle. (See Fig. 2)
4. Original system removed. (See Fig. 3)

Warning: Use extreme caution during installation. Torque all fasteners according to manufacturer's torque values and tightening sequence. **DO NOT** use air impact tools to tighten fasteners on Borla Performance Exhaust Systems. Use of such tools may result in bent flanges or gasket contact areas leading to exhaust leaks.



Borla Performance Cat-Back Exhaust System Installation

1. Place a clamp over the front pipe. (See Fig.3)
2. Insert the expanded-end of the front muffler assembly into pipe. Insert hangers into rubber isolators. Lightly tighten clamp. (See Fig. 4)
3. Place a clamp over the tailpipe assembly and place into position installing the hanger into the rubber bracket. DO NOT tighten the clamp. (See Fig. 5)
4. Check your exhaust system for proper clearance under the vehicle and also for tip alignment.
5. Once position has been determined to be correct, tighten the hardware at the flange securing the muffler assembly and the two clamps to 32-35ft. lbs. (See Fig. 6)
6. Before starting your vehicle, make sure to check all wires, hoses, brake lines, body parts and tires for safe clearance from the exhaust system.
7. Start vehicle and check for any leaks. If any leaks are found, determine cause (such as loose or incorrectly positioned clamp) and repair as necessary.

Note: When you first start your vehicle after the installation of your new Borla Performance Exhaust System, there may be some smoke and fumes coming from the system. This is a protective oil based coating used in the manufacturing of mandrel bent performance exhaust tubing. This is not a problem and will disappear within a very short period of time after the exhaust has reached normal operating temperatures.



Fig. 3

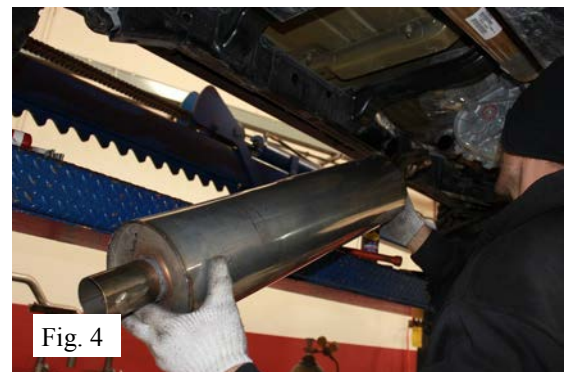

Fig. 4



Fig. 5

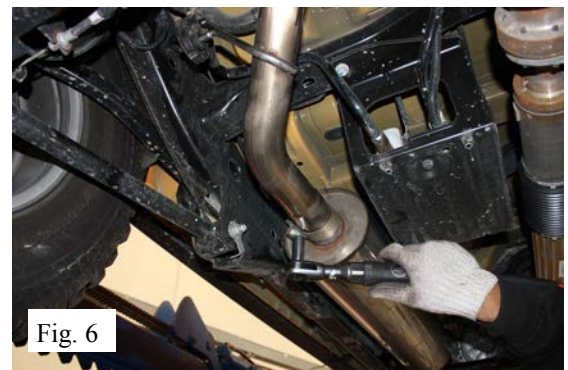

Fig. 6