

## Installation Guide for Ford F-250 PNs 140798, 140798BC, 60691, 60692, 60693



**\*\*\*\*\* Please compare the parts in the box with the bill of materials provided \*\*\*\*\*  
to assure that you have all the parts necessary for this installation.**

These instructions have been written to help you with the installation of your Borla Performance exhaust system. Please read this document completely before beginning the installation of your system.

Thank you for purchasing a Borla Performance Cat-Back™ exhaust system.

These Borla Performance Cat-Back™ exhaust systems (PNs 140798, 140798BC) are designed for the Ford F-250 & F-350 Super Duty, equipped with a 6.2L V8 engine and 2WD or 4WD automatic transmission.

Borla Performance PN 60691 is designed to complement Borla PNs 140798 and 140798BC for use on 148" wheelbase trucks.

Borla Performance PN 60692 is designed to adapt Borla PNs 140798 and 14098BC for use on 164" wheelbase trucks.

Borla Performance PN 60693 is designed to adapt Borla PNs 140798 and 140798BC for use on 176" wheelbase trucks.

Borla Performance Industries recommends that an exhaust shop or professional after market parts installer, who has all the necessary equipment, tools and experienced personnel needed for proper installation, should perform the installation of this system. However, if you decide to perform the installation, we recommend someone should help you. Ensure the installer uses all under car safety precautions including eye protection.

*Please take time to read and understand the following...*

By installing your Borla Performance exhaust system, you indicate that you have read this document and you agree with the terms stated below.

It is the responsibility of the purchaser to follow all installation instruction guidelines and safety procedures supplied with your Borla Performance Exhaust System.

Borla Performance Industries assumes no responsibility for damages occurring from misuse, abuse, improper installation, improper operation, lack of responsible care, or all previously stated reasons resulting from incompatibility with other manufacturer's products and/or systems.

Included with your Borla Performance exhaust system is a warranty card. Please read it carefully before you begin any work on your vehicle. If you should have any questions regarding our warranty policy, installation, or any other matter pertaining to your new Borla Performance exhaust system, please give us a call at the number provided on the warranty card.

**Minimum Required Tool List:**

**TOOLS:**

1. 3/8” drive ratchet
2. 3/8” drive extension 6”
3. 15mm deep well socket
4. 13mm socket
5. Pry bar

**SHOP SUPPLIES:**

1. Spray lubricant

**Borla Performance - Bill of Materials**

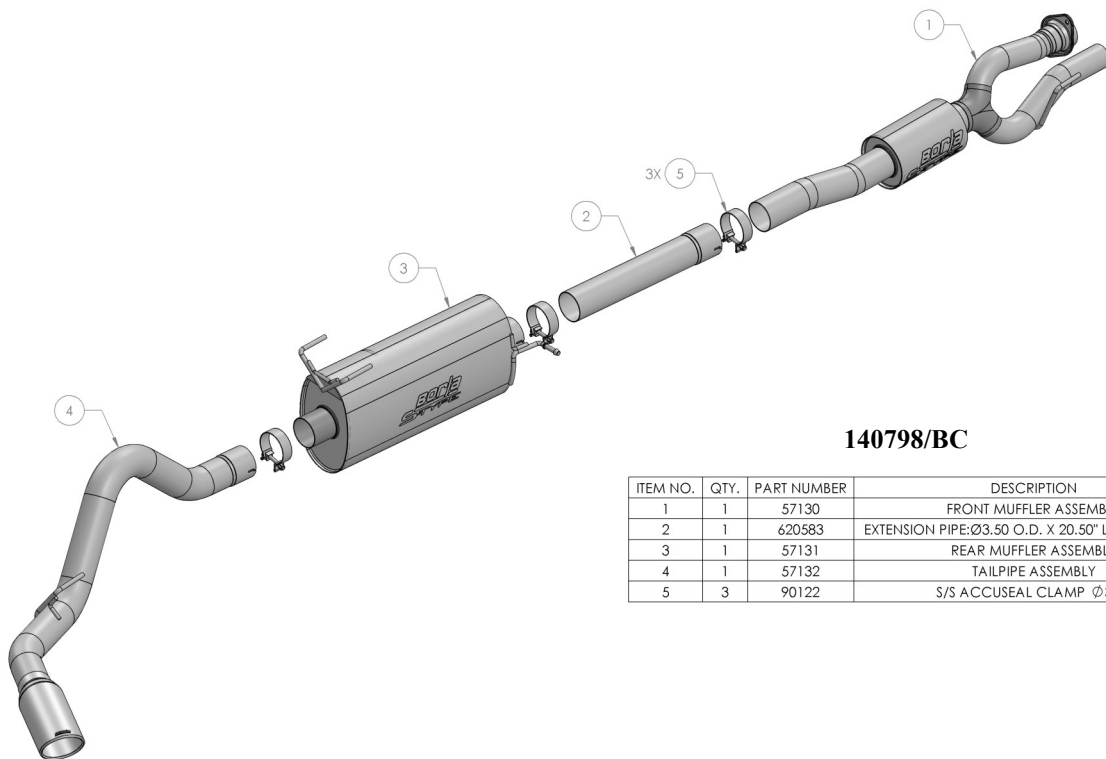

**140798/BC**

ITEM NO.	QTY.	PART NUMBER	DESCRIPTION
1	1	57130	FRONT MUFFLER ASSEMBLY
2	1	620583	EXTENSION PIPE-Ø3.50 O.D. X 20.50" LG. X Ø3.53 I.D.
3	1	57131	REAR MUFFLER ASSEMBLY
4	1	57132	TAILPIPE ASSEMBLY
5	3	90122	S/S ACCUSEAL CLAMP Ø3.50

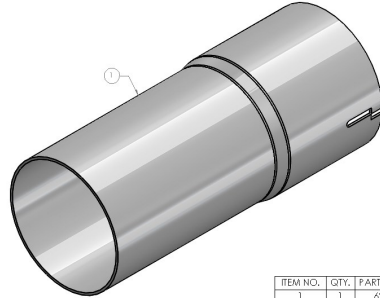

**60691**

ITEM NO.	QTY.	PART NUMBER	DESCRIPTION
1	1	620582	EXTENSION PIPE:Ø3.50 O.D. X 8.50" LG. X Ø3.53 I.D.

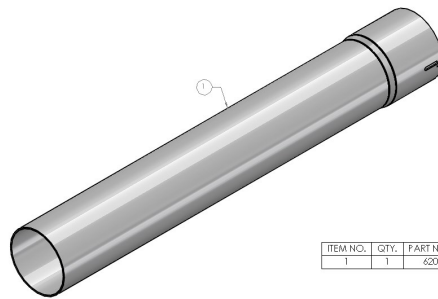

**60692**

ITEM NO.	QTY.	PART NUMBER	DESCRIPTION
1	1	620584	EXTENSION PIPE:Ø3.50 O.D. X 24.50" LG. X Ø3.53 I.D.

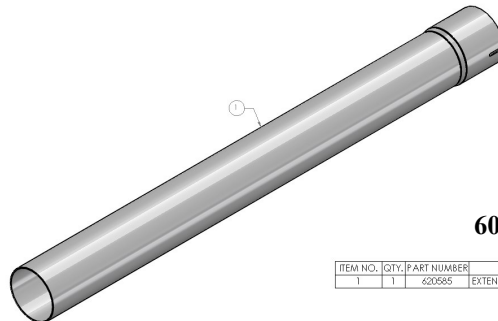

**60693**

ITEM NO.	QTY.	PART NUMBER	DESCRIPTION
1	1	620585	EXTENSION PIPE:Ø3.50 O.D. X 34.50" LG. X Ø3.53 I.D.

**Caution!!!** *Never work on a hot exhaust system. Serious injury in the form of burns can result if the vehicle has been in use and the exhaust system is hot, allow vehicle to cool for at least 1 hour. Always wear eye protection when working under any vehicle.*

**Note:** *It is our recommendation that you use a hoist or hydraulic lift to facilitate the installation of your new Borla Performance exhaust system.*

**Taking all under car safety precautions, lift the vehicle using a hoist or hydraulic lift. Once this has been done, you may begin the removal of your old exhaust system from your vehicle.**

**Note:** *Before removing the original exhaust system from your vehicle, please compare the parts you have received with the bill of materials provided on the previous page to assure that you have all the parts necessary for the installation of your new Borla Performance exhaust system.*

**Note:** *With a used vehicle, we suggest a penetrating spray lubricant to be applied liberally to all exhaust fasteners and allowing a significant period of time for the chemical to lubricate the threads before attempting to disassemble.*

## Original Exhaust System Removal

1. Lubricate all hangers, rubber isolators, bolts and nuts.
2. Remove the rear muffler assembly hangers from their rubber isolators (figs. 1, 2, 3).
3. Loosen the clamp connecting the rear muffler assembly to the mid muffler assembly (fig. 3).
4. With the rear muffler assembly and tailpipe assembly as one piece, slide the tailpipe assembly's hanger rearward out of its rubber isolator using a muffler stand or an additional person (fig. 4).
5. Loosen the clamp connecting the mid muffler assembly to the front muffler assembly and remove it (fig. 5).

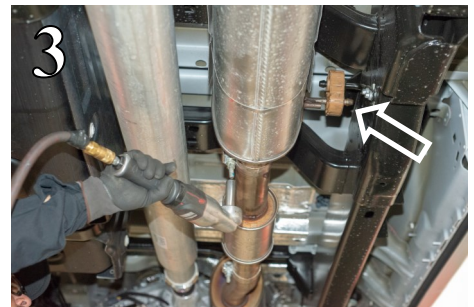
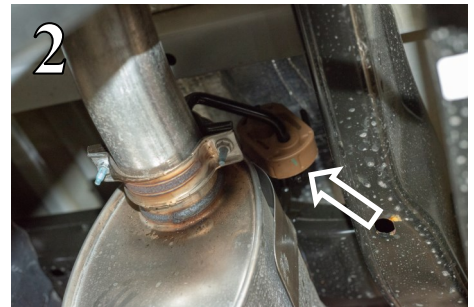
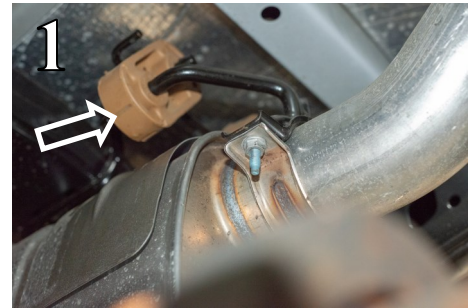

**Caution!!!** *Never work on a hot exhaust system. Serious injury in the form of burns can result if the vehicle has been in use and the exhaust system is hot, allow vehicle to cool for at least 1 hour. Always wear eye protection when working under any vehicle.*

**Note:** *It is our recommendation that you use a hoist or hydraulic lift to facilitate the installation of your new Borla Performance exhaust system.*

**Taking all under car safety precautions, lift the vehicle using a hoist or hydraulic lift. Once this has been done, you may begin the removal of your old exhaust system from your vehicle.**

**Note:** *Before removing the original exhaust system from your vehicle, please compare the parts you have received with the bill of materials provided on the previous page to assure that you have all the parts necessary for the installation of your new Borla Performance exhaust system.*

**Note:** *With a used vehicle, we suggest a penetrating spray lubricant to be applied liberally to all exhaust fasteners and allowing a significant period of time for the chemical to lubricate the threads before attempting to disassemble.*

## Original Exhaust System Removal Cont'd

7. Loosen the nuts securing the front muffler assembly flange to the vehicle (fig. 6).
8. Loosen the nuts securing the front muffler assembly rubber isolator bracket to the vehicle (fig. 7).
9. Remove the front muffler assembly rubber isolator bracket from the vehicle (fig. 8). Keep the part and hardware for later reinstallation.
10. Remove the front muffler assembly from the vehicle (fig. 9).
11. Original exhaust system removed.

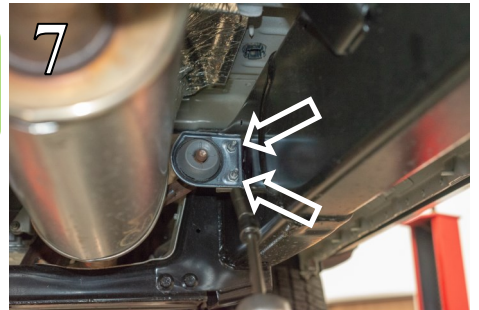

## Borla Performance Cat-Back™ Exhaust System Installation Cont'd

11. Orient the components on the shop floor according to the page-2 drawing.
12. Reinstall the front muffler rubber isolator bracket onto the vehicle (fig. 11).
13. Connect the Borla front muffler assembly to the vehicle (fig. 10).
14. Tighten the clamp connecting the front muffler assembly to the vehicle (fig. 11).
15. Tighten the nuts on the front muffler assembly flange (fig. 12).
16. Slide a clamp over the inlet of the mid pipe and connect it to the vehicle (fig. 13). Refer to this step for part numbers 60691, 60692, and 60693, replacing the included mid pipe. For 142" wheelbase trucks, use no extension pipe. For 160" wheelbase trucks, use the extension pipe included in the Cat-Back kit.
17. Slide a clamp over the inlet of the rear muffler assembly and connect it to the vehicle (fig. 14).
18. Insert the muffler assembly hangers into their rubber isolators.

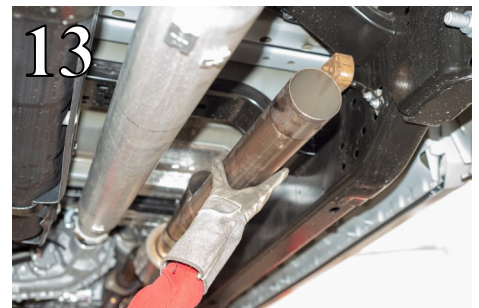
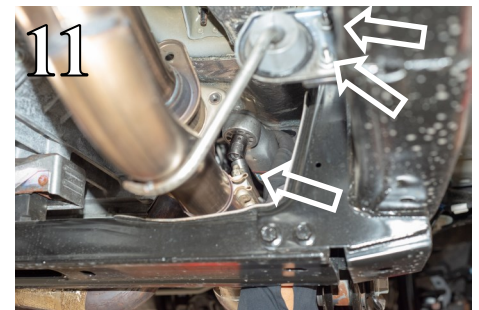

**WARNING:** Use extreme caution during installation. Torque all fasteners according to manufacturer's torque values and tightening sequence. **DO NOT** use air impact tools to tighten fasteners on Borla Performance exhaust systems. Use of such tools may result in bent flanges or gasket contact areas leading to exhaust leaks.

**NOTE:** When you first start your vehicle after the installation of your new Borla Performance exhaust system, there may be some smoke and fumes coming from the system. This is a protective oil based coating used in the manufacturing of mandrel bent performance exhaust tubing. This is not a problem and will disappear within a very short period of time after the exhaust has reached normal operating temperatures.

## Borla Performance Cat-Back™ Exhaust System Installation Cont'd

11. Slide a clamp over the inlet of the tailpipe assembly and connect it to the rear muffler assembly (fig. 15).
12. Insert the tailpipe assembly into the rubber isolator bracket from the rear.
13. Check your exhaust system for proper clearance under the vehicle and also for tip alignment (fig. 16). Starting at front flanges and moving to rear of vehicle, tighten flange hardware bolts. Orient position of bolt (on supplied clamps) between (not over) pipe notches and tighten to 35 ft. lbs. torque.
14. Align tips and tighten hardware. Loosen clamps to rotate or slide pipe for better alignment.
15. Before starting your vehicle, make sure to check all wires, hoses, brake lines, body parts and tires for safe clearance from the exhaust system.
16. Start the vehicle and check for any leaks. If any leaks are found, determine cause (such as loose or incorrectly positioned clamp) and repair as necessary.

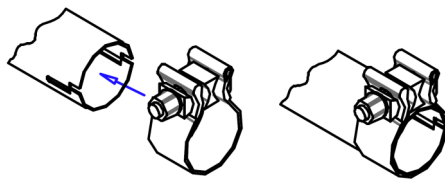

**WARNING:** Use extreme caution during installation. Torque all fasteners according to manufacturer's torque values and tightening sequence. **DO NOT** use air impact tools to tighten fasteners on Borla Performance exhaust systems. Use of such tools may result in bent flanges or gasket contact areas leading to exhaust leaks.

**NOTE:** When you first start your vehicle after the installation of your new Borla Performance exhaust system, there may be some smoke and fumes coming from the system. This is a protective oil based coating used in the manufacturing of mandrel bent performance exhaust tubing. This is not a problem and will disappear within a very short period of time after the exhaust has reached normal operating temperatures.