

Quick Installation Guide



1. System Overview

- One VTB202MINI high resolution HD CMOS color camera with the following features:
 - IP69K Waterproof Rating
 - 160 degree Wide Viewing Angle
 - 360-degree adjustable mounting angle
 - LED automatically adjusts to light conditions
 - Infrared light for improved image quality in low-light situations
 - Nightvision distance of approx 8M
- 20M Extension Cable Included
- Supplied installation accessories

2. Installation

Install the VTB202MINI as follows:

- a. Install the VTB202MINI camera in the desired location, as follows:
 - 1) Fasten the camera mounting bracket, using the 2 self-tapping Philips screws, to the desired mounting surface
 - 2) Position the camera in the camera mounting bracket. Adjust the camera to the proper angle

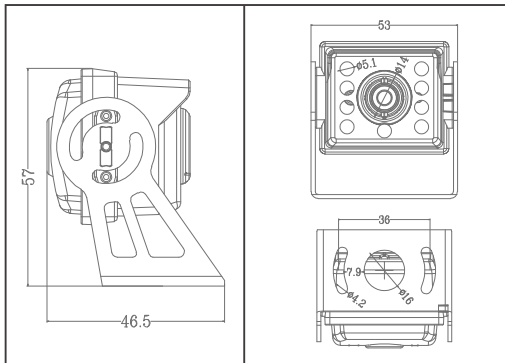
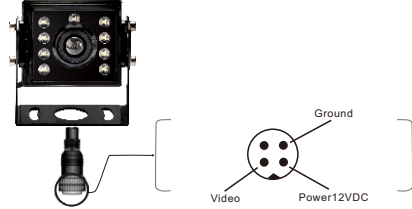

Figure 1. Installing the Camera

- b. Route the extension cable from the camera location to the location of the output device (not supplied), such as a monitor or switcher.
- c. Insert the male connector of the extension cable into the appropriate female audio/video port of the output device (not supplied), such as a monitor or switcher.

3. Grid Line Selector

The camera default setting is grid line on. To turn off the grid lines, unplug the jumper plug with the blue wires and re-power the camera for the changes to take effect.



4. Specifications

	The parameter name	specifications
1	Sensor type	cmos
2	Photosensitive size	1/4"
3	Effective pixels	1280(h)x720(V)
4	The white balance	automatic
5	Automatic gain control AGC	automatic
6	Backlight compensation	Yes
7	The noise reduction	3DDNR
8	S/N Ratio	>52dB(AGC OFF)
9	Video formats	CVBS PAL/NTSC AHD 720P@25FPS AHD 720P@30FPS
10	Video output	1.0Vp-p/75ohm
11	Ng code correction	0.45
12	voltage operating	9VDC ~36VDC
13	operating current	160mA~180mA
14	power	0.55W(U=3.3V)
15	Working temperature	-40°C ~ + 70°C
16	Whole plate thickness	4.8mm
17	Installation dimensions	Eight to edge 17mm

CAUTION: To reduce the risk of electrical shock, disconnect the battery from the electrical system of the vehicle before starting the installation.

CAUTION: Before inserting screws into the mounting surface, ensure that the underside of the mounting surface is clear of equipment that might be damaged by the screws.