



**MODEL 475/485/675/685  
NITROGEN INFLATION  
SYSTEMS**

Installation, Operation  
& Repair Parts  
Information



## TABLE OF CONTENTS

---

SAFETY INSTRUCTIONS	1
DEFINITIONS	1
SPECIFICATIONS	2
INSTALLATION INSTRUCTIONS	3
COMPONENT IDENTIFICATION	4
PURGING THE SYSTEM	5
PURITY ADJUSTMENT	5
OPERATING INSTRUCTIONS	6
TROUBLESHOOTING	8
MAINTENANCE	9
REPAIR PARTS	10
REPAIR PARTS LIST	16

## SAFETY INSTRUCTIONS

---

- NEVER allow unauthorized personnel to operate this product.
- NEVER use this product for anything other than its intended use.
- THOROUGHLY train new employees in the proper use and care of this product.
- PROHIBIT unauthorized personnel from being in shop area while this product is in use.

## DEFINITIONS

---

- **CAUTION:** Indicates a potentially hazardous situation, which if not avoided, may result in damage to property or minor personal injury.
- **HAZARD:** A source of potential injury to a person.
- **MAINTENANCE:** Those actions that preserve the correct and proper conditions under which the machine shall be used. This may include adjustment, replacement of wear items, lubrication and cleaning, but not modifications or repair of damage.
- **MAY:** This word is understood to be permissive.
- **MUST:** This word is understood to be mandatory.
- **OPERATION:** The correct and proper use of the machine as described in this manual.
- **SAFETY ALERT SYMBOL:** A symbol that indicates a potential personal safety hazard. It is composed of an equilateral triangle surrounding an exclamation point.
- **SHALL:** This word is understood to be mandatory.
- **SHOULD:** This word is understood to be advisory.
- **WARNING:** Indicates a potentially hazardous situation, which if not avoided, may result in death or serious personal injury.

## CAUTION

- ◆ Before using this product, read and fully understand the operating instructions and all decals on the product. This is necessary to prevent injury to the operator and damage to the product.
- ◆ Do not attempt to use this product for anything other than its intended purpose.
- ◆ Use of this product should be in a suitably ventilated shop.
- ◆ Operate valves slowly to prevent damage to coalescing filter.
- ◆ Use of this product is only permitted in places free from explosion or fire hazard.
- ◆ Do not use this product if it is visibly worn, distorted or damaged.

### SPECIFICATIONS

Operating Temperature	40° to 140° F (4° to 60° C)
Min/Max Compressed Air Supply	100 to 175 psi (6.9 to 12.0 bar)
Digital Inflator Accuracy	+/- 0.3 psi (0.02 bar)
Display Increments	1 psi (0.1 bar)
Dimensional data:	
Model 475 / 675	28.2 x 28.3 x 47.3 in (71.6 x 71.8 x 120.1 cm)
Model 485 / 685	31.8 x 28.3 x 47.3 in (80.7 x 71.8 x 120.1 cm)
Weight:	
Model 475	307 lbs (140 kgs)
Model 675	360 lbs (163 kgs)
Model 485	337 lbs (153 kgs)
Model 685	390 lbs (177 kgs)

Specifications shown below are at an air temperature of 75° F (24° C) and a supply air pressure of 125psi (8.6 bar). These specifications are intended to be a baseline to result in the production of 95% pure nitrogen. The output flow of nitrogen has been pre-set to 3.2 scfm (5.1 Nm<sup>3</sup>/hr) per membrane. Changes to air temperature, supply air pressure or supply air flow will change the result of nitrogen purity.

Model #	Supply Air Pressure		Supply Air Flow		Maximum Output N <sub>2</sub> Flow		N <sub>2</sub> Purity
	psi	bar	scfm	Nm <sup>3</sup> /hr	scfm	Nm <sup>3</sup> /hr	
475/485	125	8.6	6.3	10.1	3.2	5.1	95%*
675/685	125	8.6	12.6	20.2	6.4	10.1	95%*

\* These are minimum settings. The purity can be increased by rotating the purity adjustment dial clockwise.

Change	Note	Result
When supply air temperature increases	Supply air flow requirement will increase	Nitrogen Purity increases
When supply air pressure increases		
When supply air flow decreases	N <sub>2</sub> output flow will decrease	
When supply air temperature decreases		Nitrogen Purity decreases
When supply air pressure decreases		
Rotating purity adjustment dial clockwise	N <sub>2</sub> output flow will decrease	Increase Purity
Rotating purity adjustment dial counterclockwise	N <sub>2</sub> output flow will increase	Decrease Purity

## **INTENDED USE**

---

The Nitrogen Inflation System is a pneumatic device designed to generate deoxygenated air for the purpose of inflating vehicle tires.

## **INSTALLATION INSTRUCTIONS**

---

1. Unpack and remove unit from shipping carton and pallet.
2. Inspect the unit for any visible damage.
3. Make sure the installation location is free from explosion or fire hazard and is suitably ventilated, otherwise, ventilate the area periodically during use of the equipment.
4. Connect an air supply line from the nitrogen system inlet port to your compressed air source. *Be certain there is at least 30 feet of plumbing with a minimum I.D. of 3/8" between the air compressor holding tank and the inlet port of the nitrogen system. This distance is recommended to allow moist air to condense before reaching the nitrogen system.*

### **NOTE:**

- *The air supply line feeding your nitrogen system must not have an oiler or a regulator adjusted below the nitrogen system's minimum required pressure. An oiler will send oil to the nitrogen system which will prematurely plug the pre-filters.*
- *The nitrogen generator has a filter system that captures oil, water and other contaminants. However, if your air supply system generates an excessive amount of water, etc., it may be desirable to install an air dryer.*
- *The air supply should be 125 psi (8.6 bar) minimum.*

---

### **NOTICE:**

**The presence of any oil in the Nitrogen Membrane will void the manufacturer's warranty.**

---

# COMPONENT IDENTIFICATION

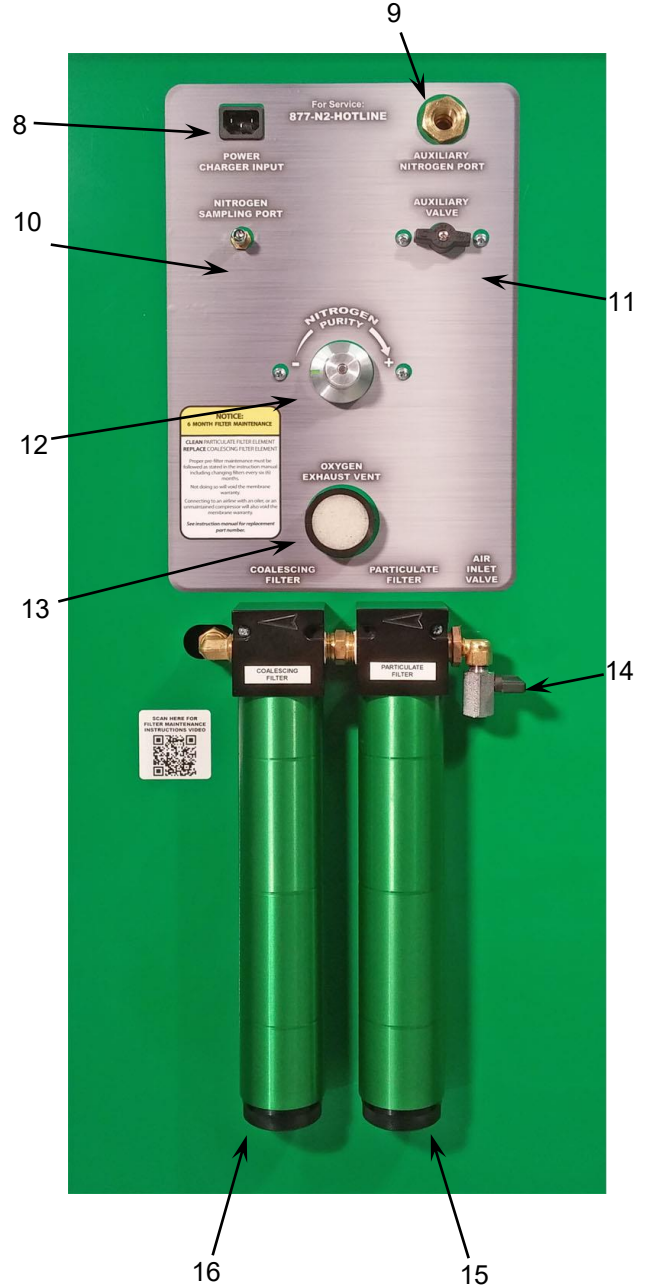
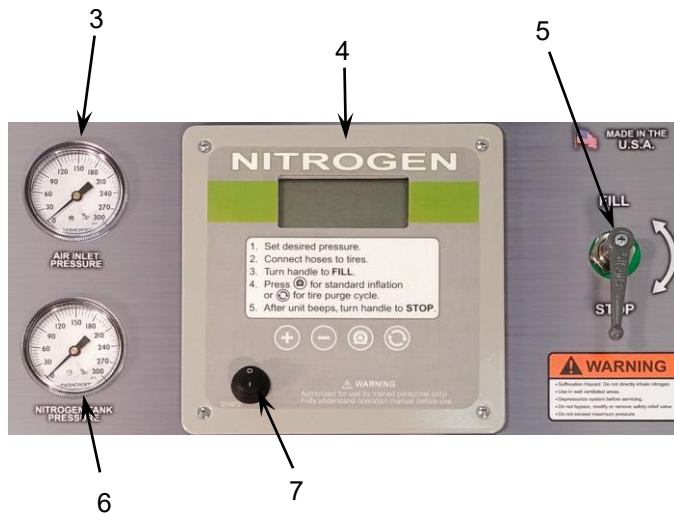
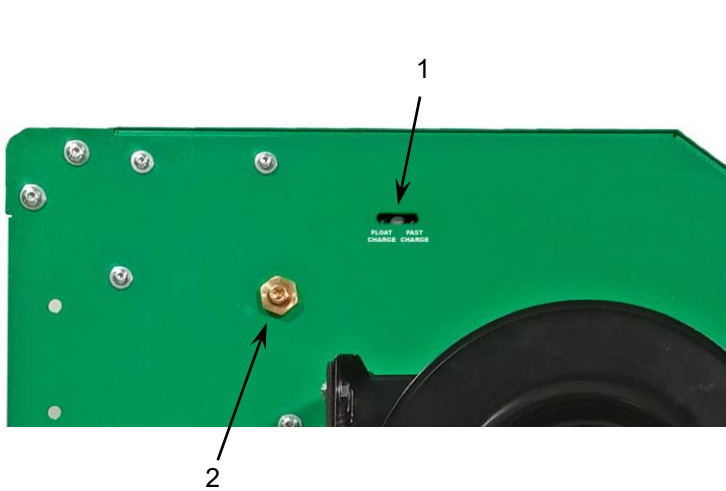

- 1 Charge Indicator
- 2 Optional Inflation Hose Port (1 each side)
- 3 Air Inlet Pressure Gauge
- 4 Digital Inflator
- 5 Tire Fill Control Valve
- 6 Nitrogen Tank Pressure Gauge
- 7 Power On/Off Button
- 8 Power Charger Input

- 9 Auxiliary Nitrogen Port
- 10 Nitrogen Sampling Port
- 11 Auxiliary Valve
- 12 Purity Adjustment Dial
- 13 Oxygen Exhaust Vent
- 14 Air Inlet Valve (1/4 NPT)
- 15 Particulate Filter
- 16 Coalescing Filter

## **PURGING THE SYSTEM (intial setup only)**

---

Now you are ready to fill the internal 30 gallon tank with nitrogen. There may be “regular” air in the tank and this must be purged to obtain the proper nitrogen purity in the tank.

1. On the particulate filter, rotate the Air Inlet Valve to the ON position (vertical).
2. On the digital inflator, flip the Power On/Off button to the ON position. The inflator will go through its status check and calibration procedure. Air will now begin to flow through the nitrogen membrane and begin to fill the internal 30 gallon tank.

**NOTE: This nitrogen system is equipped with an automatic air supply shut-off. When the tank reaches the preset pressure, the air feed will automatically shut-off. This is done to prevent unnecessary use of the air compressor. When approximately 15 psi is used from the nitrogen storage tank, the automatic shut-off will open and begin filling the storage tank again.**

3. Let the tank pressure build until the system automatically shuts-off the air supply.
4. Rotate the Air Inlet Valve to the OFF position (horizontal).
5. Open the Auxiliary Valve located on the back of the unit.
6. When the tank is empty (Tank Pressure Gauge reads 0), close the Auxiliary Valve.
7. Rotate the Air Inlet Valve to the ON position and refill the tank to full pressure.
8. Use a Nitrogen Analyzer to check the purity in the tank at the Nitrogen Sampling Port. If the purity is 95% or better, you're ready to inflate tires with nitrogen. If purity is not at least 95%, repeat steps 4 – 8.

## **PURITY ADJUSTMENT INSTRUCTIONS**

---

Your nitrogen generator is equipped with a purity adjustment dial. Nitrogen purity is factory set to a minimum of 95%. Maximum travel of the dial will vary by model but will be between 180° and 270°.

**NOTE: Increasing nitrogen purity will decrease your nitrogen flow which can increase tire fill times.**

To increase nitrogen purity, rotate the purity adjustment dial clockwise. To decrease nitrogen purity, rotate the purity adjustment dial counter-clockwise.

## **DIGITAL INFLATOR OPERATING INSTRUCTIONS**

---

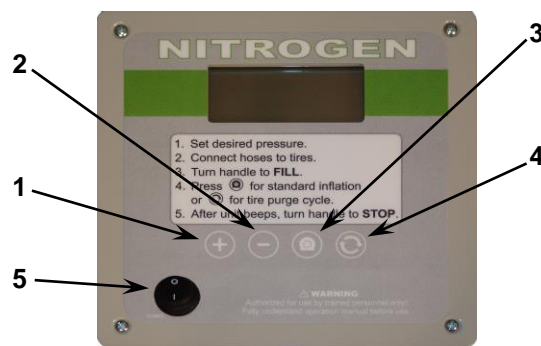

- 
- |   |  |
|---|--|
| 1 | Increase Key                                 |
| 2 | Decrease Key                                 |
| 3 | Top-Off Key                                  |
| 4 | Nitrogen Purge Cycle Key                     |
| 5 | Power “On/Off” Button                        |
| 6 | Fill Control Valve (grey handle) – not shown |
-

## **OPERATING INSTRUCTIONS**

---

### **Power Requirements & Charging instructions**

- The system is powered by an internal Sealed Lead Acid (SLA) 12 volt rechargeable battery.
- Charge system by plugging the electrical cord into the charger socket on the back of unit, and the other end into a 110/120 volt outlet.
- A completely flat battery could take up to 7 hours to charge to full.
- The charge time is dependent upon many factors including use, how often it is charged, etc. Once fully charged, the system should provide up to 8 hours of continuous operation.
- Under no circumstances should the battery be left in a flat state, designated by a blank display or diagnostic codes E10 or LO. This will significantly shorten battery life.

### **Inflator Power Up**

1. Flip the ON/OFF button of the digital inflator to the on position.
2. Display will show the following:
  - a) LCD segment check
  - b) software version and model number
  - c) mode 'N2P' for approximately 6 seconds and then display 'PCL'
  - d) battery status and display 'HI' or 'LO'
  - e) default pressure setting '32 psi'

### **Adjustment of Parameters**

#### **Default Parameters**

- Parameter nPC (Number of Purge Cycles) = 2
- Parameter OPS (Over Pressure Setting) = 0 psig
- Parameter LPL (Lower Purge Limit) = 10%
- Parameter Cti (NOT RELEVANT)
- Parameter tnP (Tank Pressure Limit) = 120 psi
- Parameter diF (Differential Pressure Limit) = 15 psi

**Number of Purge Cycles** (nPC) is adjustable between 0 and 5 cycles. Increase cycles to improve N2 tire purity.

**Over Pressure setting** (OPS) is adjustable between 0 and 29 psig. OPS will allow the inflation pressure to go beyond the set pressure by the value assigned and then back down to the target pressure.

---

## **WARNING**

**When using the OPS function, the sum pressure must not exceed the tire manufacturer's maximum inflation pressure.**

---

**Lower Purge Limit** (LPL) is adjustable between 10% and 50%. For tires with higher set pressures the low pressure threshold can be increased to reduce time and can be coupled with an increased number of N2 cycles.

**Tank Pressure Limit** (tnP) is adjustable between 87 - 174 psi. This limit should be set to approximately 10 psi lower than the incoming air pressure.







**NOTE: Setting the Tank Pressure Limit too high will cause the air compressor to run continuously.**

**Differential Pressure Limit** (diF) is adjustable between 15-58 psi. This is the pressure loss from the Tank Pressure Limit before the supply valve is opened. Increasing this limit will lower the available N<sub>2</sub> in the storage tank before the system starts to generate more N<sub>2</sub>.

**Example:** To alter the number of purge cycles, follow these steps:



1. Turn on the power supply.
2. Display will show and check all LCD digits.
3. Display will show the current firmware version number, e.g., '.3.1.9'.
4. Display will show the program model variant, e.g., '349'.
5. Display will show the current application mode, 'N2P'.

**Note: During stages 2-5 do not press any buttons. During this phase the unit is being calibrated.**

6. After approximately 6 seconds the display will show 'PCL'. Press the  button.
7. Display will show nPC, press the  button to enter.
8. Display will show '2', press the  or  buttons to the desired number of cycles.
9. Press the  button to confirm.
10. Exit from the program by pressing the  button twice.
11. Inflator will now reboot with the new settings.

## Tire Fill Procedures

### Converting air filled tires to nitrogen





1. Place the Fill Control Valve handle to the STOP position and flip the ON/OFF button to the on position.
2. Firmly attach the tire fill hoses to the valve stems of the tire(s) and ensure that leaks do not exist.
3. Set the target tire pressure with the  and  buttons on the front panel.

**Note: The target pressure should be the vehicles recommended tire pressure found in the owner's manual, on the sticker inside the driver's door jamb, or inside the fuel access door.**



4. Turn the Fill Control Valve handle to FILL.
5. Press the  button to start the nitrogen conversion.
6. When the alarm sounds the cycle is complete.
7. Turn the Fill Control Valve handle to STOP and remove hoses from valve stems.
8. To turn off the power to the inflator flip the ON/OFF button to off.

### Filling tires to two different pressures

Some vehicles require two different tire pressure settings from the front tires to the rear. In this example, we will use target pressures of 32 psi in the front and 40 psi in the rear.

1. Go through steps 1 through 6, as mentioned above in "Converting air-filled tires to nitrogen" using the lowest of the two pressures (32 psi) as the target pressure.
2. After step 6, turn Fill Control Valve handle to STOP. Disconnect the hoses from the tires that are at their final pressure (in this example the front tires are at 32 psi).
3. Change the target pressure for the remaining two tires using the  or  buttons (in this example press the  button to 40 psi).
4. Turn the grey Fill Control Valve handle to the 'FILL' position.
5. Press the  button.
6. When the alarm sounds the cycle is complete.
7. Turn the Fill Control Valve handle to STOP and remove hoses from valve stems.
8. To turn off the power to the inflator, flip the ON/OFF button to off.

### To top off tires already filled with nitrogen

1. Place the Fill Control valve to the STOP position and flip on the ON/OFF button to turn on the power.
2. Firmly attach the tire fill hoses to the valve stems of the tire/tires and ensure that leaks do not exist.
3. Set the target tire pressure with the  and  buttons on the front panel.

**Note: The target pressure should be the vehicles recommended tire pressure found in the owner's manual, on the sticker inside the driver's door jamb, or inside the fuel access door.**

4. Turn the Fill Control valve handle to FILL.
5. Press the  button.
6. When the alarm sounds the cycle is complete.
7. Turn the Fill Control valve handle to STOP and remove hoses from valve stems.



8. To turn off the power to the inflator, flip the ON/OFF button to off.

**Emergency Stop**

To stop the inflation / deflation cycle, press any button on the front panel or turn the Fill Control valve handle from FILL to STOP.

***TROUBLESHOOTING / DIAGNOSTIC CODES***

The following diagnostic codes are reported via the inflator display.

<b>Problem / Code</b>	<b>Possible Cause</b>	<b>Solution</b>
Hose connectors leak and will not seal to the tire valve stem	Hose Connectors are worn out or not properly seated on the valve stem	Replace connectors or reseal on the valve stem
Hose connectors leak while not connected to the tire valve stem	Hose Connectors are worn	Replace connectors
No Display	No power connected	Switch power on
Buzzer does not sound	Buzzer volume has been turned off Buzzer is damaged	Turn buzzer on Replace buzzer
Inflation process starts but does not complete	Low or no supply pressure Leaks exist	Check supply pressure Confirm leaks do not exist
E1	Unstable or insufficient supply pressure	Check the supply pressure
E4	Small volume, caused inflator to check pressure > 29psi over target pressure	Check hose to see if kinked or blocked
E5	Unit powered ON under pressure; i.e., hose is connected to tire and control valve set to FILL	Turn control valve to STOP and cycle the power ON/OFF again
E6	Pressure sensor drift out	New sensor required Contact Customer Service
E8	Pressure sensor disconnected from PCB or faulty	New sensor required Contact Customer Service
E9	Pressure sensor failure - high	New sensor required Contact Customer Service
E10 or LO	Under voltage	Check power supply
E11	Over voltage	Check power supply
E12	Checksum corrupted	New PCB required Contact Customer Service
E13	Lost or corrupted calibration settings	New PCB required Contact Customer Service
E17	Calibration data corrupted	Calibration is required Contact Customer Service
E19	Capacitive touch interface error	Contact Customer Service
E18, E20, E21,E22,E23,E28	Software error	Contact Customer Service

## **MAINTENANCE**

---

**NOTE:** To avoid personal injury or damage to the Nitrogen Inflation System, permit only qualified personnel to perform maintenance. **When cleaning or replacing filter elements and automatic float drains, disconnect airline from filters and turn Air Inlet valve to ON to allow air to drain from system. When Air Inlet Pressure Gauge reads zero psi, you can service the filters.**

See repair parts breakdown for replacement parts.

**ALWAYS:**      **Keep Nitrogen Inflation System clean.**

**DAILY:**        **Check the automatic float drain on all filters for proper operation.**

If the automatic float drain should become stuck open or inoperable, shut off the air supply (see NOTE above). Remove the bottom cap from the bottom of the filter. The drain can be cleaned in hot soapy water. DO NOT attempt to disassemble the drain. If the drain is still inoperable after cleaning, it will have to be replaced. When installing a new drain, make sure the o-ring is installed on the bottom stem before screwing it into the bottom cap. Finger tighten only.

**WEEKLY:**      **Clean the automatic float drain on both filters.**

See above.

**BI-YEARLY:**   **Clean particulate filter element and replace coalescing element.**

---

# REPAIR PARTS

## HOSE CONNECTING LEGEND

EXAMPLE: A2    A = HOSE "A"  
                   2 = FIGURE NUMBER

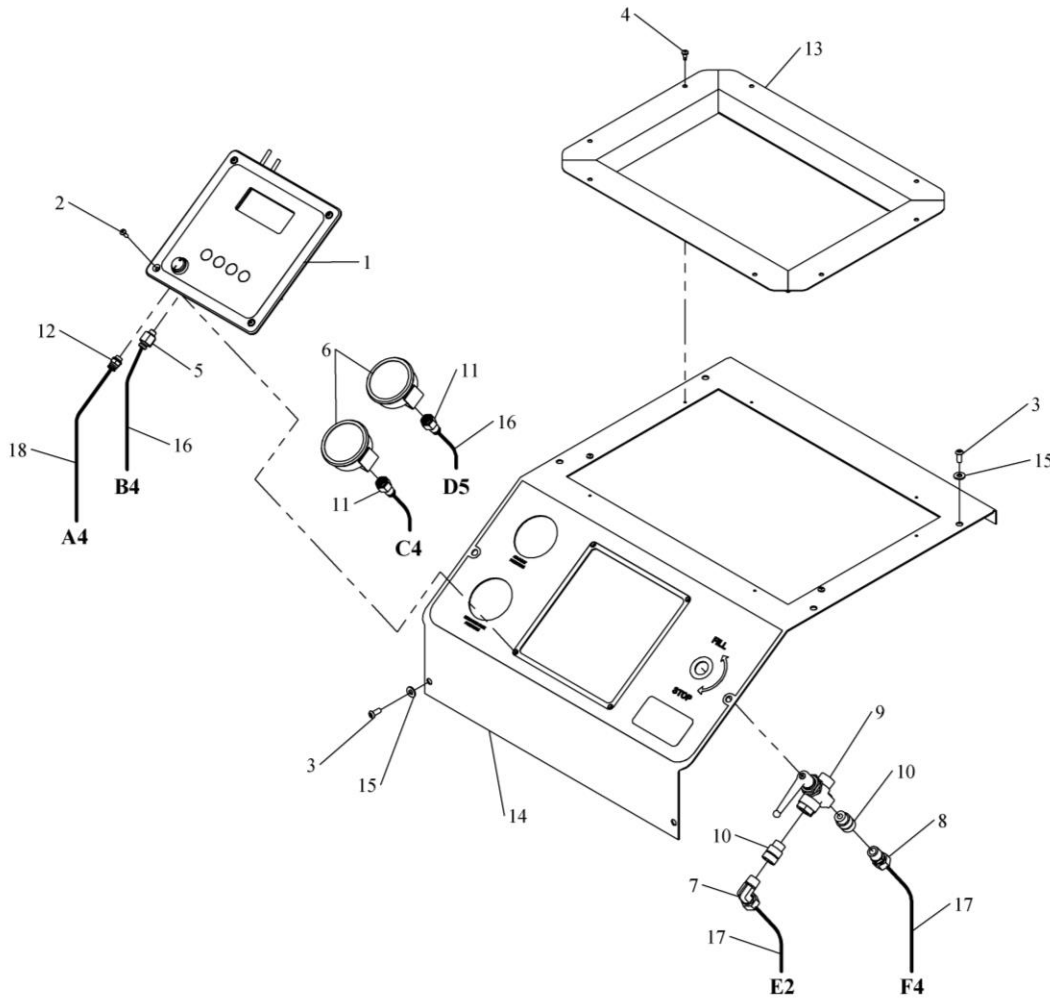

**Top Panel Detail**  
 FIGURE 1

ITEM	QTY	P/N	DESCRIPTION	ITEM	QTY	P/N	DESCRIPTION
1	1	40-0087	Digital Inflator	10	2	60-0237	3/8 BSPP to NPT Adapter
2	4	50-0103	#8-32 x 1/2 Machine Screw	11	2	60-0343	1/4 NPT x 1/4 Tube Fitting
3	10	50-0125	1/4-20 x 5/8 Button Capscrew	12	1	60-0345	1/8 BSPP x 6mm Tube Fitting
4	8	50-0141	#10-16 x 1/2 Screw	13	1	72-0463	Tray
5	1	60-0166	1/8 BSPP x 1/4 Tube Fitting	14	1	72-0468	Top Cover
6	2	60-0167	Pressure Gauge	15	10	108-110	1/4 Flat Washer
7	1	60-0175	3/8 NPT x 1/2 Tube 90° Fitting	16	-	D20-002	1/4 O.D. Tube (green)
8	1	60-0177	3/8 NPT x 1/2 Tube Fitting	17	-	D20-031	1/2 O.D. Tube (black)
9	1	60-0235	3-Way Ball Valve	18	-	D20-041	1/4 O.D. Tube (red)



## Tank & Membrane

ITEM	QTY	P/N	DESCRIPTION
1	1	03-0617	Base Frame
2	1	10-0029	Grommet
3	4	10-0031	Foam Pad
4	8	028-002	5/16-18 x 5/8 Capscrew
5	4	028-034	1/2-13 x 1-1/4 Capscrew
6	2	028-307	#10-24 x 1-3/4 Machine Screw
7	1	039-008	1/2 NPT x 1/4 NPT Reducer Bushing
8	2	055-157	3/4-10 Lock Nut
9	8	055-105	5/16-18 Flange Lock Nut
10	2	055-127	#10-24 Lock Nut
11	4	055-156	1/2-13 Lock Nut
12	1	60-0074	3/8 NPT Plug
13	1	60-0117	Ball Valve
14	1	60-0144	Pop-Off Valve
15	2	60-0175	3/8 NPT x 1/2 Tube 90° Fitting
16	2	60-0176	1/2 Tube Tee
17	4	60-0181	1/2 NPT x 1/2 Tube 90° Fitting
18	1	60-0190	3/4 NPT x 3/8 NPT Reducer Bushing
19	6	60-0191	1/4 NPT x 3/8 Tube Fitting
20	2	60-0198	1/2 NPT x 3/4 Barb 90° Fitting
21	1	60-0229	Manifold
22	1	60-0334	1 x 3/4 Barb Wye Fitting
23	1	60-0335	1 NPT Vent
24	1	60-0336	1 NPT 90° Fitting
25	1	60-0337	1 NPT x 1 Barb Adapter Fitting
26	1	61-0039	Square Profile O-Ring
27	2	64-0022	N2 Separator
28	1	69-0013	30 gal. Tank
29	1	72-0464	Support Bracket
30	2	106-016	Wheel
31	2	106-014	Swivel Caster
32	8	108-044	1/2 Flat Washer
33	-	D20-006	3/8 O.D. Tube (black)
34	-	D20-031	1/2 O.D. Tube (black)
35	-	D20-032	3/4 I.D. Braided Tube
36	-	D20-038	1 I.D. Tube

## HOSE CONNECTING LEGEND

EXAMPLE: A2    A = HOSE "A"  
                   2 = FIGURE NUMBER

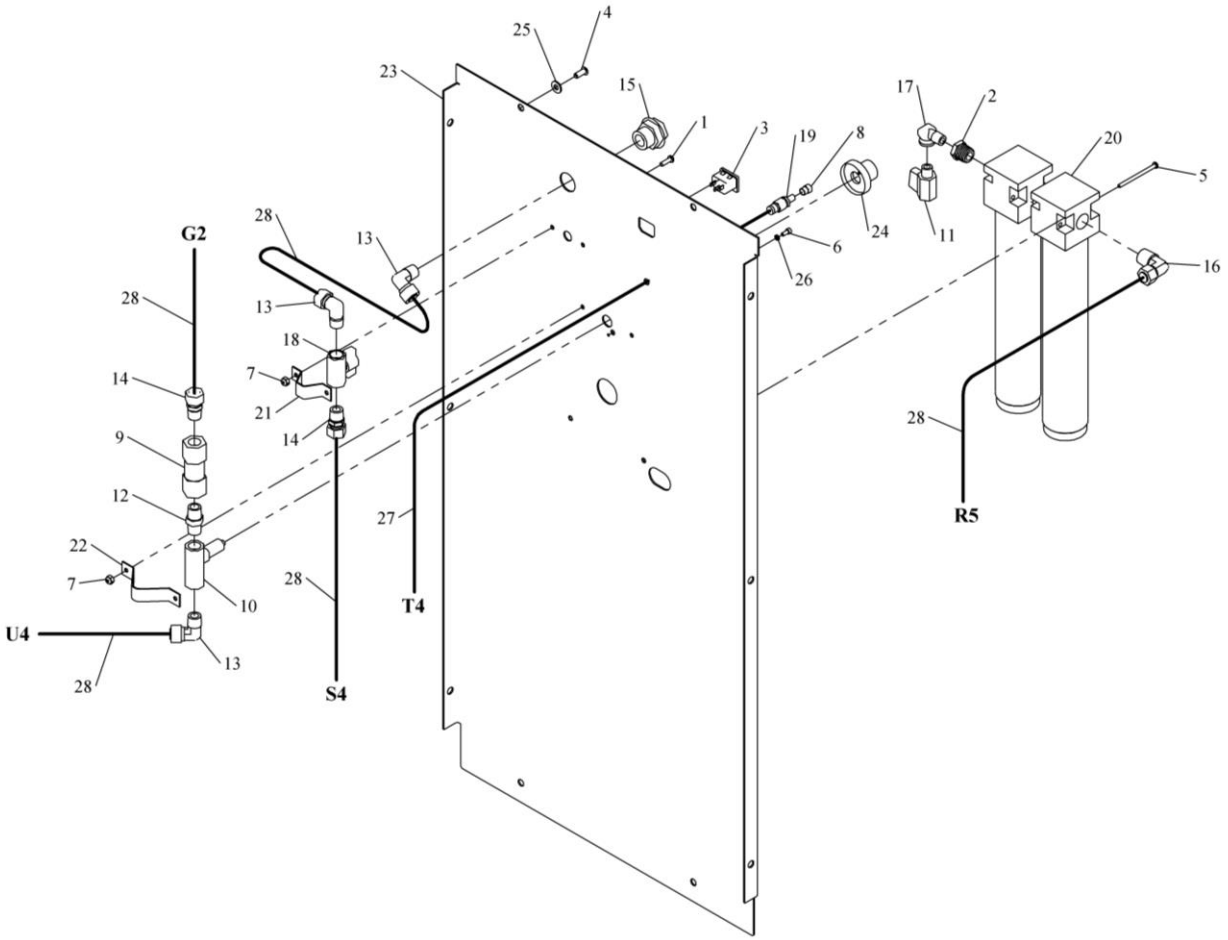

**Rear Panel Detail**  
 FIGURE 3

ITEM	QTY	P/N	DESCRIPTION	ITEM	QTY	P/N	DESCRIPTION
1	4	028-155	#10-24 x 5/8 Machine Screw	17	1	60-0194	1/4 NPT M x F 90° Fitting
2	1	039-008	1/2 NPT x 1/4 NPT Rdcr Bushing	18	1	60-0195	3/8 NPT Ball Valve
3	1	43-0048	Power Entry Module	19	1	60-0196	1/4 Schrader Valve
4	10	50-0125	1/4-20 x 5/8 Button Capscrew	20	1	64-0016	Filter Assembly
5	2	50-0137	#8-32 x 2-1/2 Machine Screw	21	1	72-0206	Ball Valve Bracket
6	1	50-0148	#8-32 x 3/8 Capscrew	22	1	72-0209	Needle Valve Bracket
7	4	055-127	#10-24 Lock Nut	23	1	72-0469	Back Panel
8	1	59-0021	Valve Stem Cap	24	1	73-1100	Purity Adjustment Dial
9	1	60-0114	Check Valve	25	10	108-110	1/4 Flat Washer
10	1	60-0115	Flow Control Valve	26	1	108-168	#8 Split Lock Washer
11	1	60-0117	1/4 NPT Ball Valve	27	-	D20-002	1/4 O.D. Tube (green)
12	1	60-0134	3/8 NPT Hex Nipple	28	-	D20-031	1/2 O.D. Tube (black)
13	3	60-0175	3/8 NPT x 1/2 Tube 90° Fitting	29	-	64-0017	Coalescing Filter Element
14	2	60-0177	3/8 NPT x 1/2 Tube Fitting	30	-	64-0021	Mesh Filter Element
15	1	60-0178	3/8 NPT x 1-14 Bulkhead	31	-	69-0020	Automatic Float Drain
16	1	60-0181	1/2 NPT x 1/2 Tube 90° Fitting				

\* Items not shown

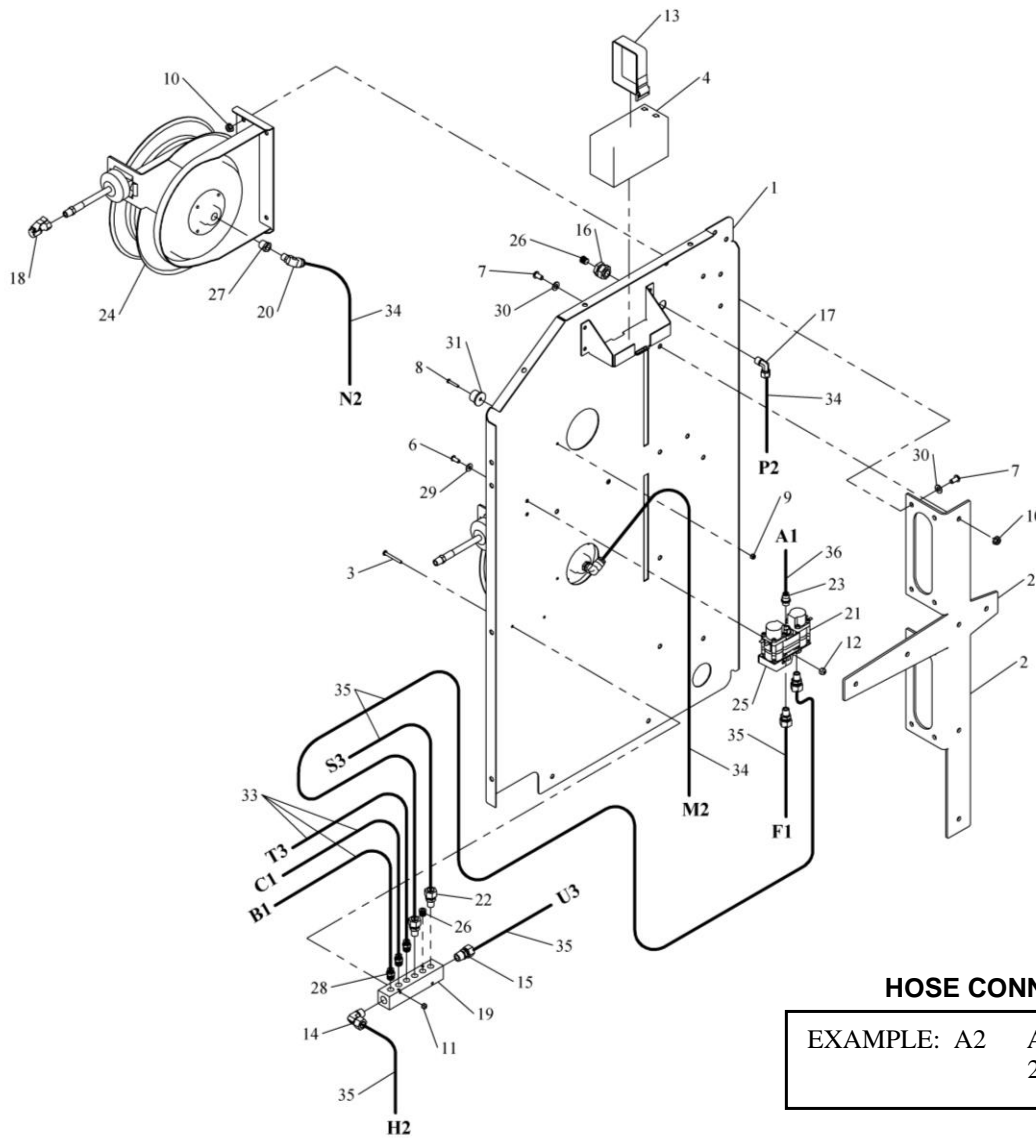

**HOSE CONNECTING LEGEND**

EXAMPLE: A2    A = HOSE "A"  
                   2 = FIGURE NUMBER

**Left Panel Detail**  
**FIGURE 4**

ITEM	QTY	P/N	DESCRIPTION	ITEM	QTY	P/N	DESCRIPTION
1	1	03-0619	Side Panel - left	19	1	60-0229	Manifold
2	1	06-0116	Hose Reel Bracket - left	20	2	60-0231	1/4 NPT x 3/8 Tube 90° Fitting
3	2	028-307	#10-24 x 1-3/4 Machine Screw	21	1	60-0256	Solenoid Valve
4	1	40-0063	Battery	22	4	60-0316	1/4 NPT x 1/2 Tube Fitting
5	1	42-0024	Battery/Inflator Harness	23	1	60-0344	1/4 BSPP x 6mm Tube Fitting
6	15	50-0125	1/4-20 x 5/8 Button Capscrew	24	2	62-0032	Hose Reel
7	17	50-0126	5/16-18 x 5/8 Button Capscrew	25	1	72-0331	Solenoid Bracket
8	2	50-0149	#8-32 x 1 Machine Screw	26	2	096-004	1/4 NPT Plug
9	2	055-082	#8-32 Lock Nut	27	2	096-039	3/8 NPT x 1/4 NPT Rdcr Bushing
10	17	055-105	5/16-18 Flange Lock Nut	28	3	096-340	1/4NPT x 1/4 Tube Fitting
11	2	055-127	#10-24 Lock Nut	29	15	108-110	1/4 Flat Washer
12	2	055-160	1/4-20 Lock Nut	30	17	108-123	5/16 Flat Washer
13	1	59-0085	Battery Strap	31	2	808-018	Grommet
14	1	60-0175	3/8 NPT x 1/2 Tube 90° Fitting	32	-	D10-007	Foam Tape
15	1	60-0177	3/8 NPT x 1/2 NPT Fitting	33	-	D20-002	1/4 O.D. Tube (green)
16	1	60-0192	1/4 NPT x 3/4-16 Bulkhead	34	-	D20-006	3/8 O.D. Tube (black)
17	1	60-0193	1/4 NPT x 3/8 Tube 90° Fitting	35	-	D20-031	1/2 O.D. Tube (black)
18	2	60-0201	Air Chuck (closed)	36	-	D20-041	1/4 O.D. Tube (red)

\* Items not shown

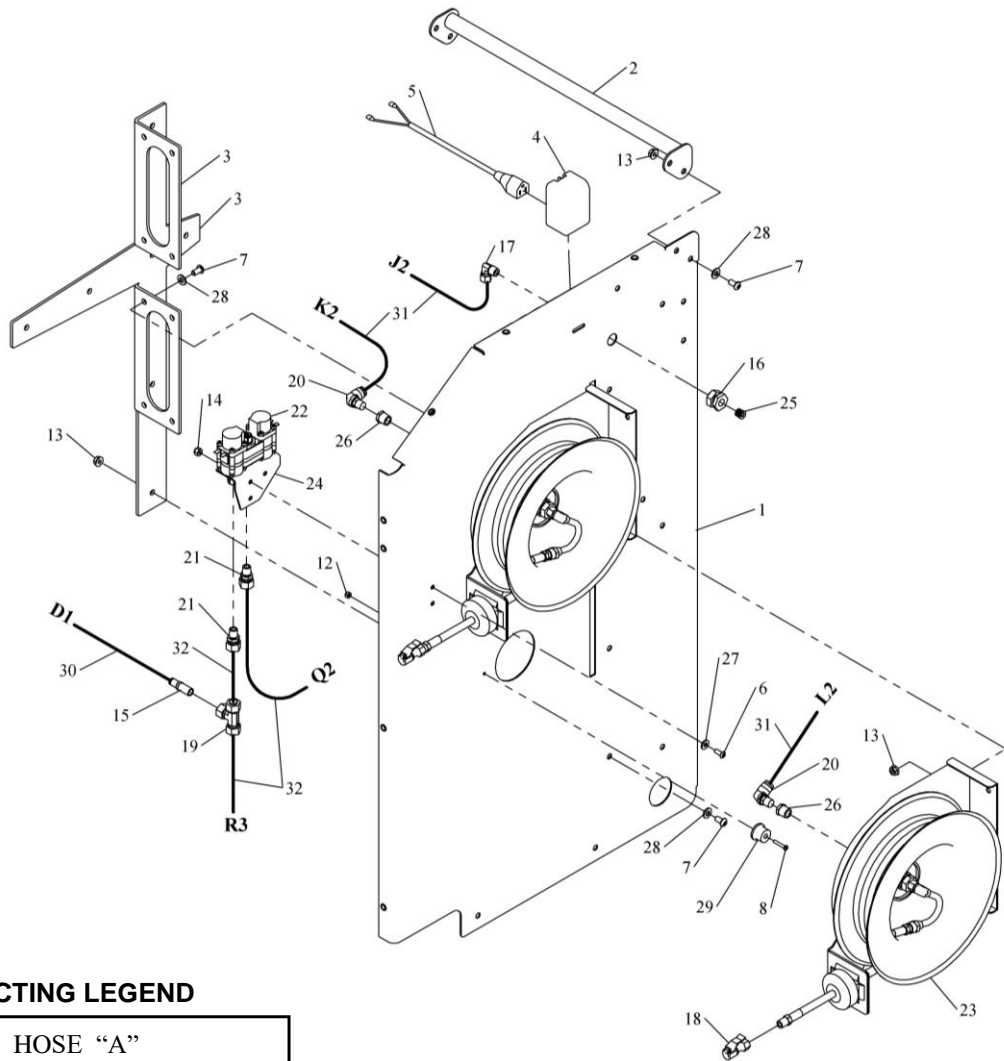

### HOSE CONNECTING LEGEND

EXAMPLE: A2    A = HOSE "A"  
                   2 = FIGURE NUMBER

## Right Panel Detail

FIGURE 5

ITEM	QTY	P/N	DESCRIPTION	ITEM	QTY	P/N	DESCRIPTION
1	1	03-0618	Side Panel - right	17	1	60-0193	1/4 NPT x 3/8 Tube 90° Fitting
2	1	03-0620	Handle	18	2	60-0201	Air Chuck (closed)
3	1	06-0115	Hose Reel Bracket - right	19	1	60-0176	1/2 Tube Tee
4	1	40-0064	Charger	20	2	60-0231	1/4 NPT x 3/8 Tube 90° Fitting
5	1	42-0025	Power Harness	21	2	60-0316	1/4 NPT x 1/2 Tube Fitting
6	15	50-0125	1/4-20 x 5/8 Button Capscrew	22	1	60-0328	Tank Solenoid Valve
7	17	50-0126	5/16-18 x 5/8 Button Capscrew	23	2	62-0032	Hose Reel
8	2	50-0149	#8-32 x 1 Machine Screw	24	1	72-0331	Solenoid Bracket
9	3	53-0001	Tie Wrap - small	25	1	096-004	1/4 NPT Plug
10	3	53-0002	Adhesive Mount - small	26	2	096-039	3/8 NPT x 1/4 NPT Rdcr Bushing
11	1	53-0028	Tie Wrap - medium	27	15	108-110	1/4 Flat Washer
12	2	055-082	#8-32 Lock Nut	28	17	108-123	5/16 Flat Washer
13	17	055-105	5/16-18 Flange Lock Nut	29	2	808-018	Grommet
14	2	055-160	1/4-20 Lock Nut	30	-	D20-002	1/4 O.D. Tube (green)
15	1	60-0139	1/2 Tube x 1/4 Tube Reducer	31	-	D20-006	3/8 O.D. Tube (black)
16	1	60-0192	1/4 NPT x 3/4-16 Bulkhead	32	-	D20-031	1/2 O.D. Tube (black)

\* Items not shown



## HOSE CONNECTING LEGEND

EXAMPLE: A2    A = HOSE "A"  
                   2 = FIGURE NUMBER

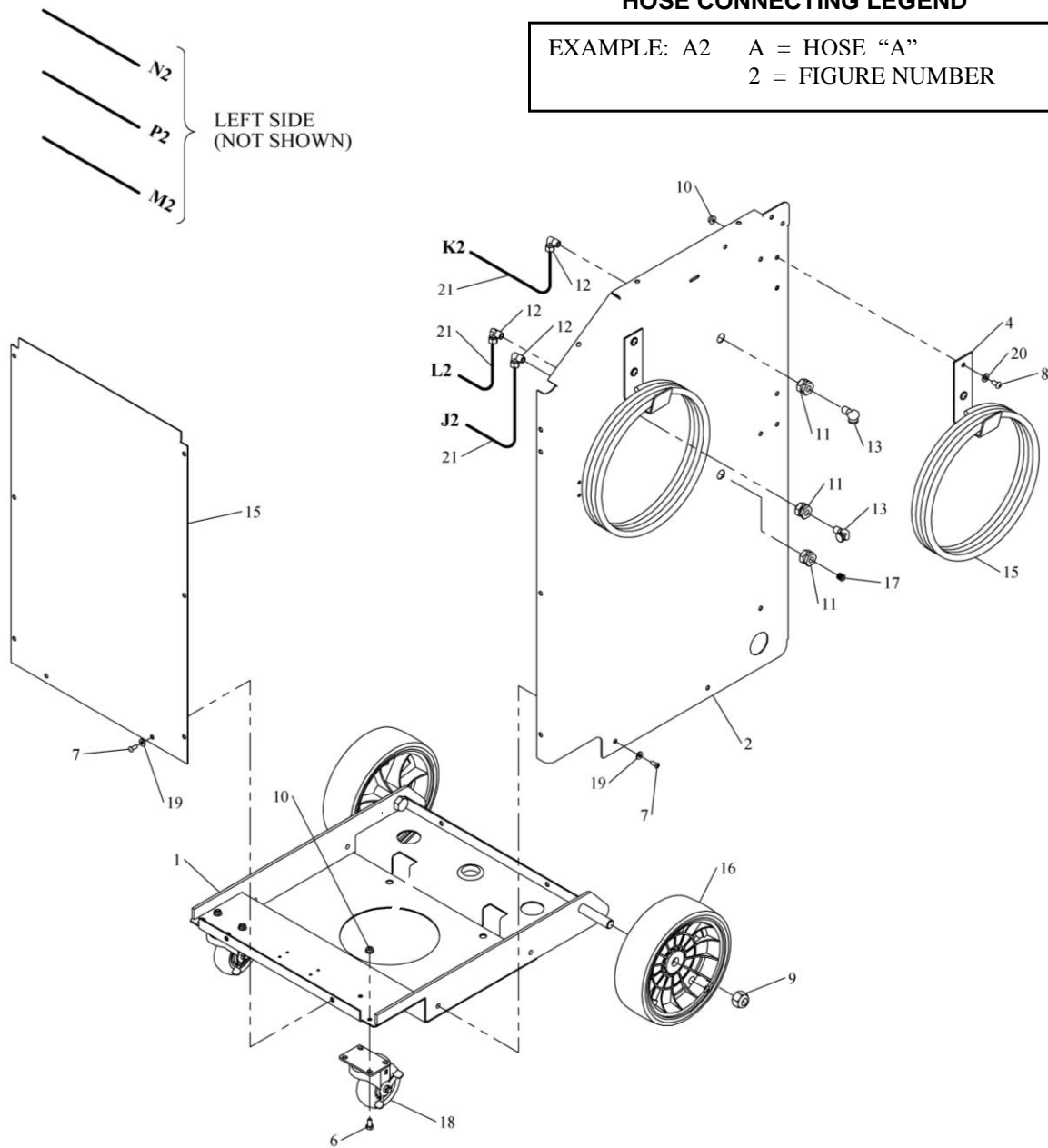

## Right Panel, Model 475/675

FIGURE 6

ITEM	QTY	P/N	DESCRIPTION	ITEM	QTY	P/N	DESCRIPTION
1	1	03-0617	Base Frame	11	6	60-0193	1/4 NPT x 3/8 Tube 90° Fitting
2	1	03-0621	Side Panel (475/675) - right	12	4	60-0194	1/4 NPT M x F 90° Fitting
3	1	03-0622	Side Panel (475/675) - left	*	13	62-0020	Air Hose with Chuck
4	4	06-0047	Hose Bracket	14	1	72-0470	Front Panel
5	8	028-002	5/16-18 x 5/8 Capscrew	15	2	106-016	Wheel
6	32	50-0125	1/4-20 x 5/8 Button Capscrew	16	2	096-004	1/4 NPT Plug
7	12	50-0126	5/16-18 x 5/8 Button Capscrew	17	2	106-014	Swivel Caster
8	2	055-157	3/4-10 Lock Nut	18	32	108-110	1/4 Flat Washer
9	20	055-105	5/16-18 Flange Lock Nut	19	12	108-123	5/16 Flat Washer
10	6	60-0192	1/4 NPT x 3/4-16 Bulkhead	20	-	D20-006	3/8 O.D. TUBE (black)

\* Items not shown