



MODEL 5550
Tire Repair
Station

Installation, Operation
and Repair Parts
Information



TABLE OF CONTENTS

SAFETY INSTRUCTIONS	1
DEFINITIONS	1
INSTALLATION INSTRUCTIONS	2
OPERATING INSTRUCTIONS	2
MAINTENANCE INSTRUCTIONS	3
REPAIR PARTS	

SAFETY INSTRUCTIONS

- NEVER allow unauthorized personnel to operate this product.
- NEVER use this product for anything other than its intended use.
- THOROUGHLY train new employees in the proper use and care of this product.
- PROHIBIT unauthorized personnel from being in shop area while this product is in use.

DEFINITIONS

- **CAUTION:** Indicates a potentially hazardous situation, which if not avoided, may result in damage to property or minor personal injury.
- **WARNING:** Indicates a potentially hazardous situation, which if not avoided, may result in death or serious personal injury.
- **HAZARD:** A source of potential injury to a person.
- **MAINTENANCE:** Those actions that preserve the correct and proper conditions under which the machine shall be used. This may include adjustment, replacement of wear items, lubrication and cleaning, but not modifications or repair of damage.
- **MAY:** This word is understood to be permissive.
- **MUST:** This word is understood to be mandatory.
- **OPERATION:** The correct and proper use of the machine as described in this manual.
- **SAFETY ALERT SYMBOL:** A symbol that indicates a potential personal safety hazard. It is composed of a triangle surrounding an exclamation point.
- **SHALL:** This word is understood to be mandatory.
- **SHOULD:** This word is understood to be advisory.

CAUTION

- ◆ Before using this product, read and fully understand the operating instructions and all decals on the product. This is necessary to prevent injury to the operator and damage to the product.
- ◆ Use this product only for lifting, spreading and repairing tire casings. Do not use this product for any other purpose.
- ◆ Keep fingers and hands clear of spread hooks during tire spread.
- ◆ Do not use this product if it is visibly worn, distorted or damaged.
- ◆ Always wear appropriate eye protection.

WARNING

- ◆ Keep feet clear of the tire ramp and scissor arms when raising and lowering spreader platform.
- ◆ All personnel must be clear of the tire lift area during operation.

INSTALLATION

- 1) Position the Model 5550 on a solid level floor, leaving adequate clearance to operate the machine.
- 2) Attach the ramp and ramp linkage to the front of the Model 5550. Use the supplied 3/8" bolts and lock nuts to attach the ramp to the brackets on the end of the platform. Slide the linkage rod through the linkages and mounts at the base of the unit with the linkages on the outside of the mounts. Place the supplied washer over the end of the rod and insert the cotter pin, bending the tabs to secure the pin.
- 3) Attach a 1/4" NPT quick coupler nipple (not provided) into the in-line filter located on the base frame below the tool tray. Use a 1/4" air hose with a supply pressure of no more than 150 psi maximum.

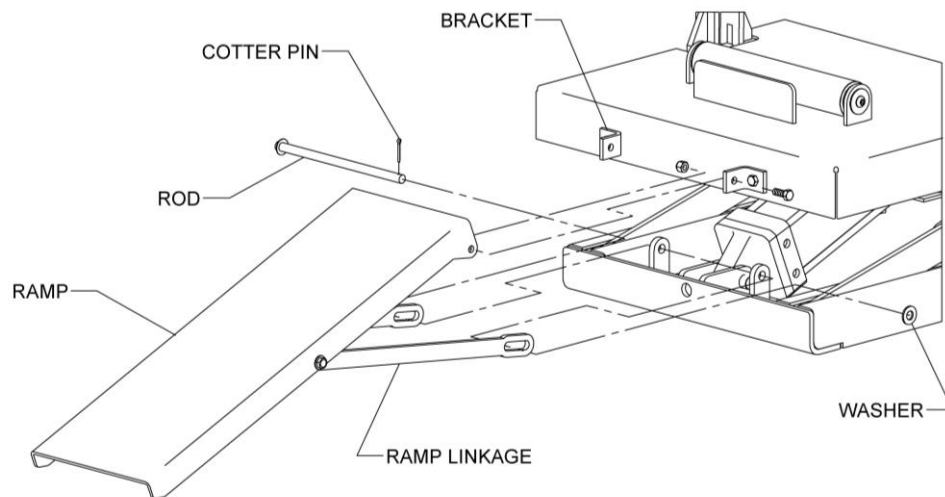

OPERATION

- 1) Rotate the spread hooks out into the upright position.
- 2) Make sure the spreader platform is in the lowest position. If not lower it using the foot pedals.
- 3) Roll the tire up the ramp and onto the platform rollers. Steady the tire with your hand while placing the spread hooks over the tire bead.
- 4) Raise the spreader platform to a comfortable working height using the foot pedals.
- 5) To adjust the spread hooks to the proper height, pull out on the locking pin knob and move the adjustable posts to the correct height. Release the knob and ensure the post is locked. Most large truck tires use the uppermost adjustment hole. Both posts must be adjusted to the same height.
- 6) Spread the tire to the desired width using the hand levers at the rear of the platform. If the tire lifts off the rollers when spread, adjust the posts to a lower position.
- 7) After the tire repairs are complete, lower the platform to its lowest position.
- 8) Release the pressure on the spread arms and lift the hooks out of the tire.
- 9) Steady the tire and roll it down the ramp using both hands.

MAINTENANCE

If maintenance is required, a Locking Key is supplied to hold the platform in the raised position. Keys are located on both sides of the spreader base frame. To use, raise the platform to its highest position and insert the Key into the locked position. The platform will remain in this position when air is disconnected. Do not remove the Key until the air supply is restored. Replace the key in the stored position when maintenance is complete.

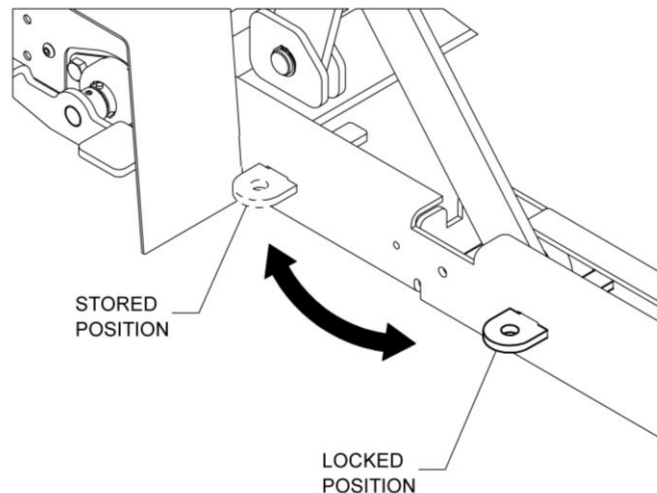

REPAIR PARTS

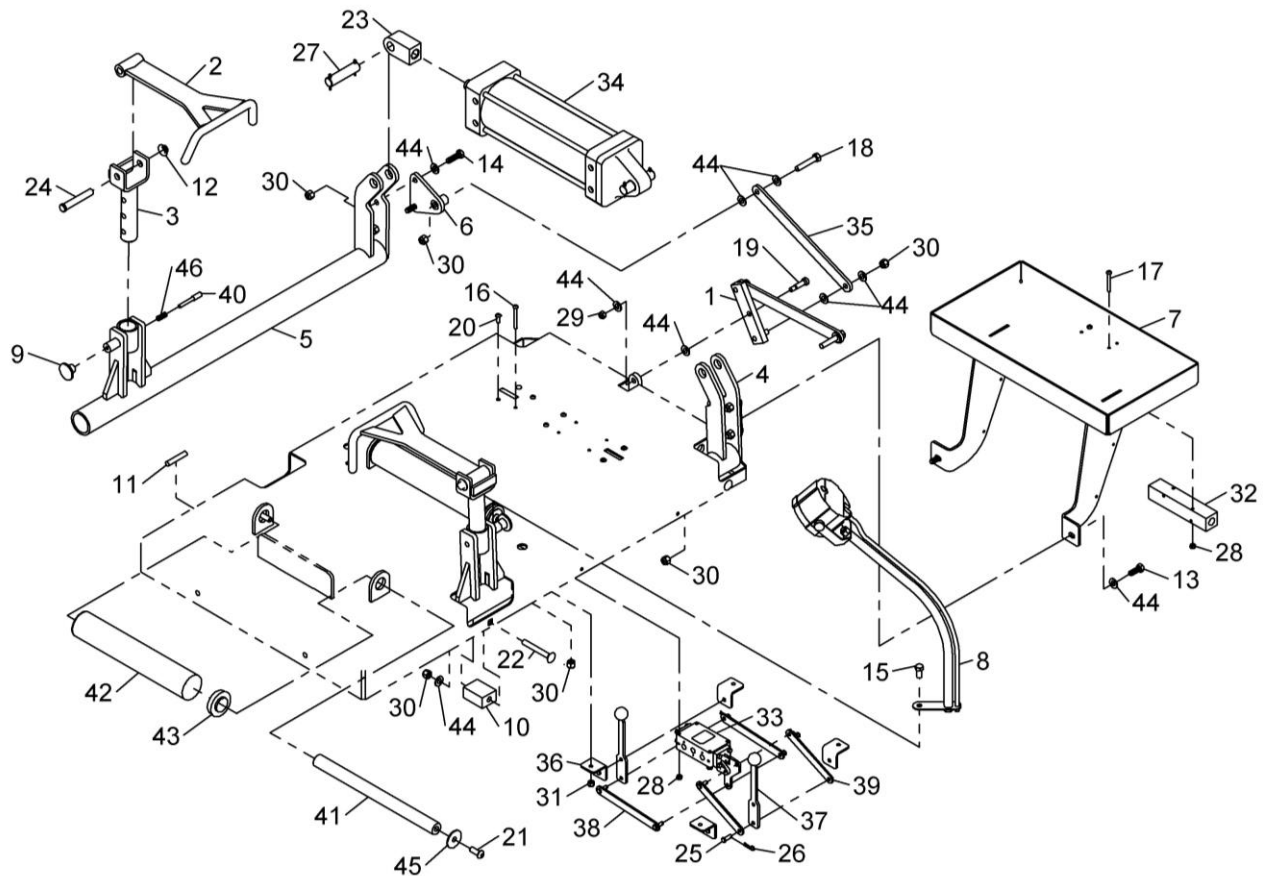

SPREAD ASSEMBLY

ITEM	QTY	PART NO.	DESCRIPTION	ITEM	QTY	PART NO.	DESCRIPTION
1	1	03-0036	LINKAGE PIVOT	24	2	54-0034	1/2 X 3 PIN
2	2	03-0302	SPREAD HOOK	25	6	54-0056	1/4 X 3/4 PIN
3	2	03-0308	ADJUSTABLE POST	26	6	54-0057	HAIR PIN
4	1	03-0664	RIGHT SPREAD ARM	27	2	54-0061	3/4 PIN
5	1	03-0665	LEFT SPREAD ARM	28	6	055-127	#10 NYLON LOCK NUT
6	2	03-0666	EQUALIZER MOUNT	29	1	055-145	5/16 NYLON LOCK NUT
7	1	03-0667	TOOL TRAY	30	15	055-154	3/8 NYLON LOCK NUT
8	1	40-0090	LED LIGHT	31	4	055-160	1/4 NYLON LOCK NUT
9	2	11-0109	PULL KNOB	32	1	60-0233	MANIFOLD
10	4	11-0133	SPREAD ARM REST	33	1	60-0372	SPREAD VALVE
11	8	11-0134	SPREAD ARM SPACER	34	1	63-0037	4 X 10 AIR CYLINDER
12	2	020-024	CAP	35	2	71-0436	SPREAD LINKAGE
13	2	028-021	3/8 X 1 SCREW	36	4	72-0494	HANDLE MOUNT
14	4	028-046	3/8 X 1-1/4 SCREW	37	2	72-0495	HANDLE
15	1	028-133	3/8 X 3/4 SCREW	38	2	72-0496	LOWER LINKAGE
16	4	028-305	#10 X 2 SCREW	39	2	72-0497	UPPER LINKAGE
17	2	028-307	#10 X 1-3/4 SCREW	40	2	73-1000	LOCK PIN
18	2	028-329	3/8 X 2 SCREW	41	2	73-1202	ROLLER ROD
19	1	50-0027	3/8 X 1 SHOULDER SCREW	42	2	74-0387	ROLLER TUBE
20	4	50-0125	1/4 X 5/8 BTN SCREW	43	4	107-016	ROLLER BEARING
21	4	50-0167	3/8 X 1 BTN SCREW	44	20	108-015	3/8 FLAT WASHER
22	4	50-0207	3/8 X 3 CARRIAGE BOLT	45	4	108-141	3/8 FENDER WASHER
23	1	53-0038	ROD CLEVIS	46	2	110-065	SPRING

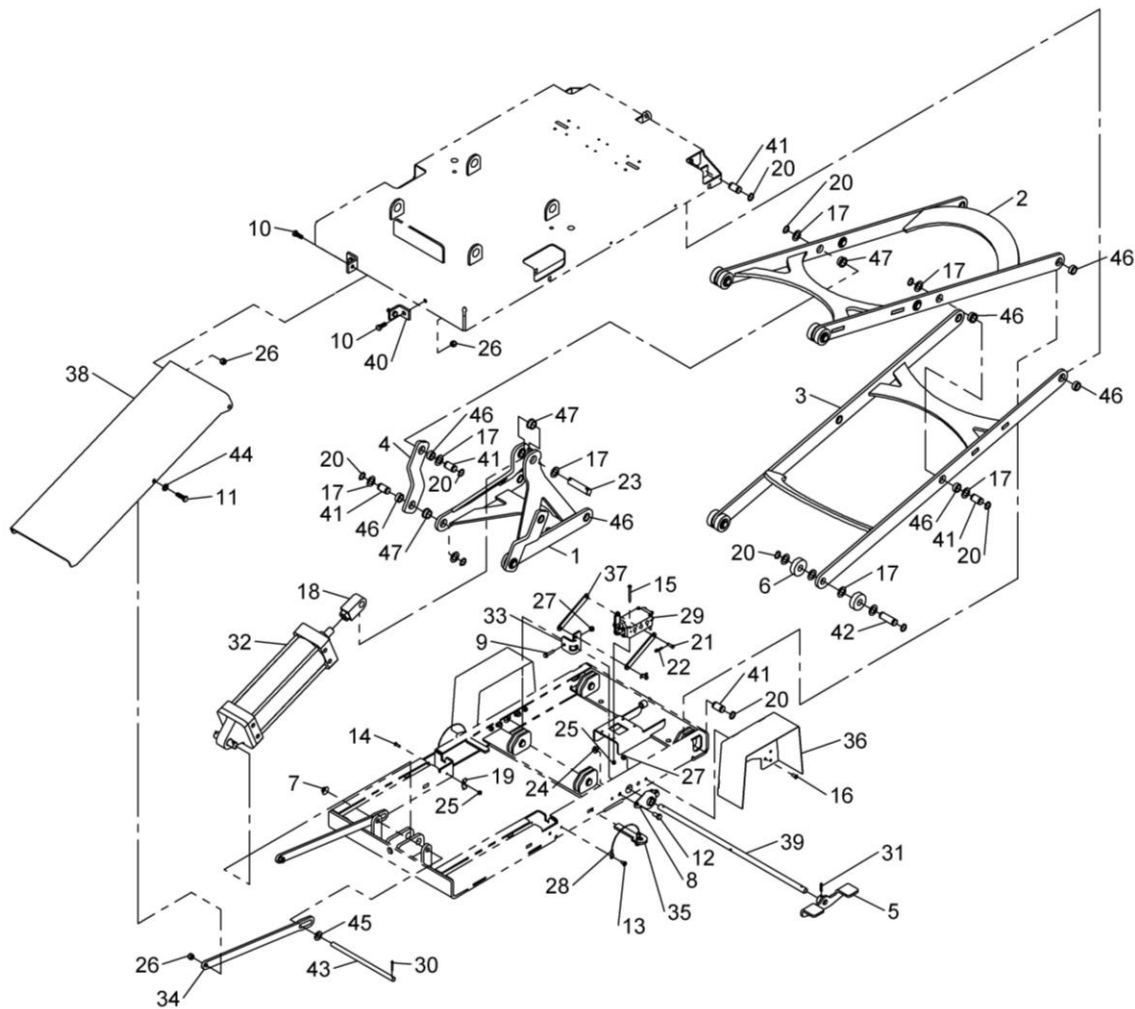

LIFT ASSEMBLY

ITEM	QTY	PART NO.	DESCRIPTION	ITEM	QTY	PART NO.	DESCRIPTION
1	1	01-0278	BELL CRANK	25	5	055-127	#10 NYLON LOCK NUT
2	1	01-0279	INNER LIFT ARM	26	6	055-154	3/8 NYLON LOCK NUT
3	1	01-0280	OUTER LIFT ARM	27	5	055-160	1/4 NYLON LOCK NUT
4	2	01-0281	LIFT LINKAGE	28	2	59-0087	LANYARD
5	2	03-0306	FOOT PEDAL	29	1	60-0371	LIFT VALVE
6	8	11-0132	LIFT ROLLER	30	1	061-023	COTTER PIN
7	1	020-024	CAP	31	2	061-178	SPRING PIN
8	2	20-0039	FLANGE BEARING	32	1	63-0037	4 X 10 AIR CYLINDER
9	1	028-011	1/4 X 1-1/4 SCREW	33	1	71-0443	VALVE CLEVIS
10	4	028-021	3/8 X 1 SCREW	34	2	71-0455	RAMP LINKAGE
11	2	028-046	3/8 X 1-1/4 SCREW	35	2	71-0469	LIFT LOCK
12	4	028-133	3/8 X 3/4 SCREW	36	2	72-0086	FOOT GUARD
13	2	028-148	1/4 X 1/2 SCREW	37	2	72-0497	UPPER LINKAGE
14	1	028-155	#10 X 5/8 SCREW	38	1	72-0585	RAMP
15	4	028-305	#10 X 2 SCREW	39	1	73-0734	FOOT VALVE ROD
16	4	50-0125	1/4 X 5/8 BTN SCREW	40	2	73-0743	RAMP BRACKET
17	30	52-0062	SHIM SPACER	41	12	73-1198	LINKAGE PIN
18	1	53-0038	ROD CLEVIS	42	4	73-1199	ROLLER PIN
19	1	53-0039	ROUTING CLAMP	43	1	73-1200	RAMP LINKAGE ROD
20	32	54-0045	RETAINING RING	44	2	108-015	3/8 FLAT WASHER
21	2	54-0056	1/4 X 3/4 PIN	45	1	108-044	1/2 FLAT WASHER
22	2	54-0057	HAIR PIN	46	12	20-0066	SLEEVE BUSHING
23	2	54-0061	3/4 PIN	47	8	20-0067	FLANGED SLEEVE BUSHING
24	4	055-103	3/8 FLANGE NUT				

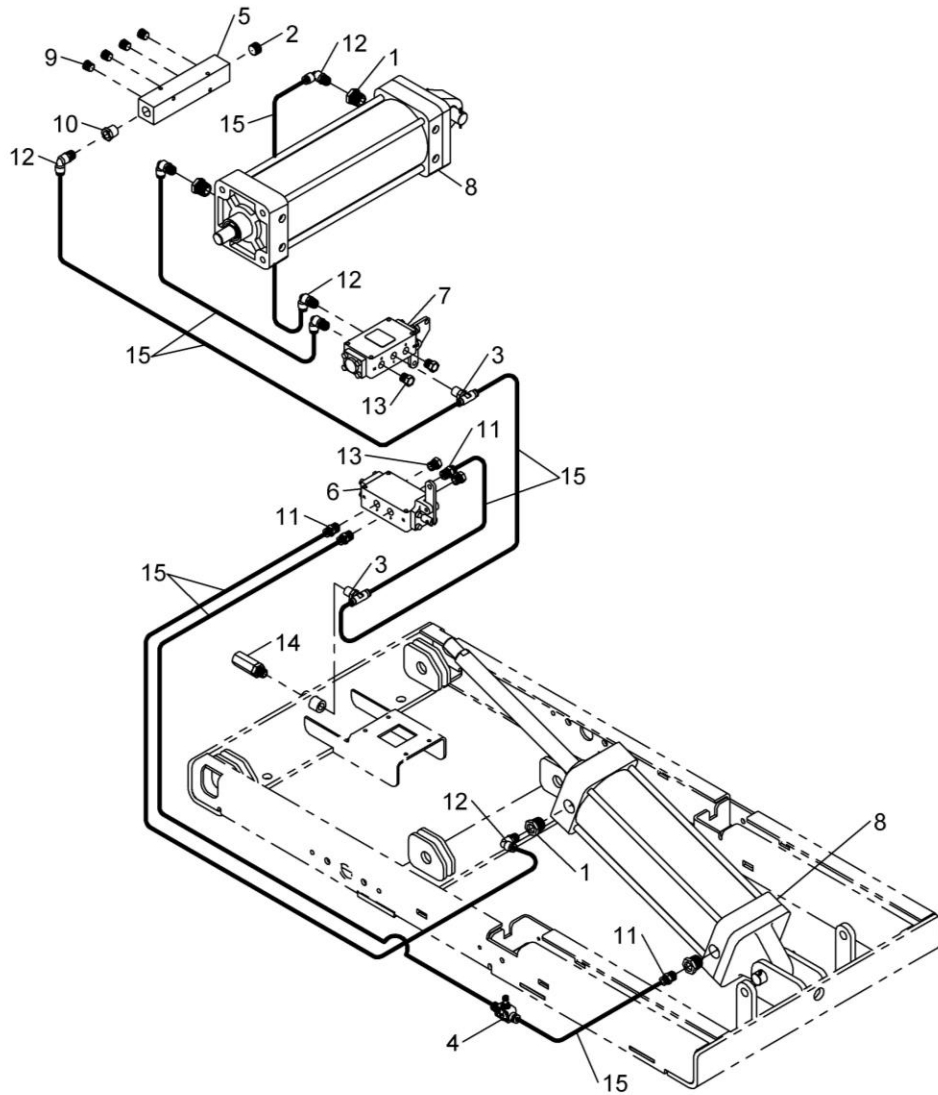

PNEUMATICS

ITEM	QTY	PART NO.	DESCRIPTION
1	4	039-008	1/2 TO 1/4 REDUCER FITTING
2	1	60-0074	3/8 NPT PLUG
3	2	60-0164	1/4 NPT TO 1/4 TUBE TEE FITTING
4	1	60-0220	FLOW CONTROL
5	1	60-0233	MANIFOLD
6	1	60-0371	LIFT VALVE
7	1	60-0372	SPREAD VALVE
8	2	63-0037	4 X 10 AIR CYLINDER
9	4	096-004	1/4 NPT PLUG
10	1	096-039	3/8 TO 1/4 REDUCER FITTING
11	4	096-340	1/4 NPT TO 1/4 TUBE FITTING
12	6	096-342	1/4 ELBOW FITTING
13	4	885-035	BREATHER FITTING
14	1	932-001	IN-LINE FILTER
15	1	D20-007	1/4 AIR LINE